

"WiFly GSX" 802.11G Module

Features

- Qualified 2.4GHz IEEE 802.11b/g transceiver
- High throughput, 4Mbps sustained data rate with TCP/IP and WPA2
- Ultra-low power (10uA sleep, 50mA Rx, 100mA Tx)
- Small, compact surface mount module
- On board ceramic chip antenna and U.FL connector for external antenna
- 8 Mbit flash memory and 128 KB RAM
- UART and SPI data/control interfaces
- 10 general purpose digital I/O
- 8 analog sensor interfaces
- Real-time clock for wakeup and time stamping
- Accepts 3.3V regulated or 2-3V battery
- Supports Adhoc connections
- On board ECOS -OS, TCP/IP stacks
- Wi-Fi Alliance certified for WPA2-PSK
- FCC / CE/ ICS certified and RoHS compliant.



Description

The WiFly GSX module is a stand alone, embedded wireless 802.11 networking module. Because of its small form factor and extremely low power consumption, the RN-131G is perfect for mobile wireless applications such as asset monitoring, GPS tracking and battery sensors. The WiFly GSX module incorporates a 2.4GHz radio, processor, TCP/IP stack, real-time clock, crypto accelerator, power management and analog sensor interfaces. This complete solution is preloaded with software to simplify integration and minimizes development of your application. In the simplest configuration the hardware only requires four connections (PWR, TX, RX, GND) to create a wireless data connection. Additionally, the sensor interface provides temperature, audio, motion, acceleration and other analog data without requiring additional hardware. The WiFly GSX module is programmed and controlled with a simple ASCII command language. Once the WiFly GSX is setup it can scan to find an access point, associate, authenticate and connect over any Wifi network

Applications

- Wireless audio
- Remote equipment monitoring
- Telemetry
- Security
- Industrial sensors and controls
- Home Automation
- Medical devices

Block Diagram

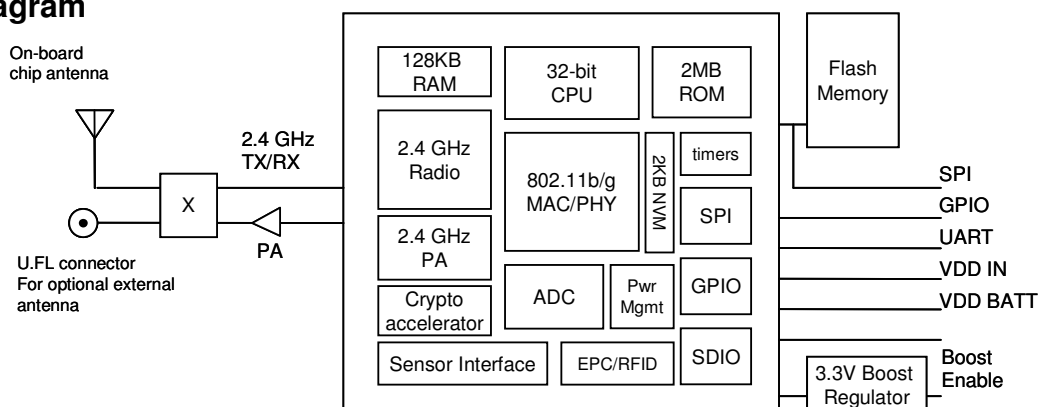

Overview

- Host Data Rate Up to 100 Mbps for SDIO, 44 Mbps for SPI and 2.7 Mbps for UART
- Throughput 4 Mbps with TCP/IP and WPA2
- Memory 128 KB RAM, 2MB ROM, 2 KB battery-backed memory, 8 Mbit Flash.
- Intelligent, built-in power management with programmable wakeup
- Can be powered from regulated 3.3-3.7V source or 2.0-3.0V batteries
- Real time clock for time stamping, auto-sleep and auto-wakeup modes
- Configuration over UART or wireless interfaces using simple ASCII commands
- Over the air firmware upgrade (FTP), and data file upload.
- On board flash can be used for custom applications, data logging, stored data forwarding to the network
- Secure WiFi authentication WEP-128, WPA-PSK (TKIP), WPA2-PSK, EAP-TLS for WPA1 & WPA2 Enterprise
- Built in networking applications DHCP, UDP, DNS, ARP, ICMP
- 802.11 power save and roaming functions

Environmental Conditions

Parameter	Value
Temperature Range (Operating)	-40 °C ~ 85 °C
Temperature Range (Storage)	-40°C ~ 85 °C
Relative Humidity (Operating)	≤90%
Relative Humidity (Storage)	≤90%

Electrical Characteristics

Supply Voltage	Min	Typ.	Max.	Unit
Supply Voltage VDD	3.0	3.3	3.7	VDC
Supply Voltage (VBATT option)	2.0	3.0	3.3	VDC
Average power consumption				
Sleep		4		uA
Standby (doze)	-	15	-	mA
Connected (idle, RX)		40		mA
Connected (TX)		140	212	mA

Radio Characteristics

Parameter	Specifications
Frequency	2402 ~ 2480MHz
Modulation	DSSS(CCK-11, CCK-5.5, DQPSK-2, DBPSK-1)
Channel intervals	5MHz
Channels	1 - 14
Transmission rate (over the air)	1 – 11Mbps for 802.11b / 6 – 54Mbps for 802.11g
Receive sensitivity	-85dBm typ.
Output level (Class1)	+18dBm
Maximum RF input to U.FL connector	10 dBm

Typical Application Schematic

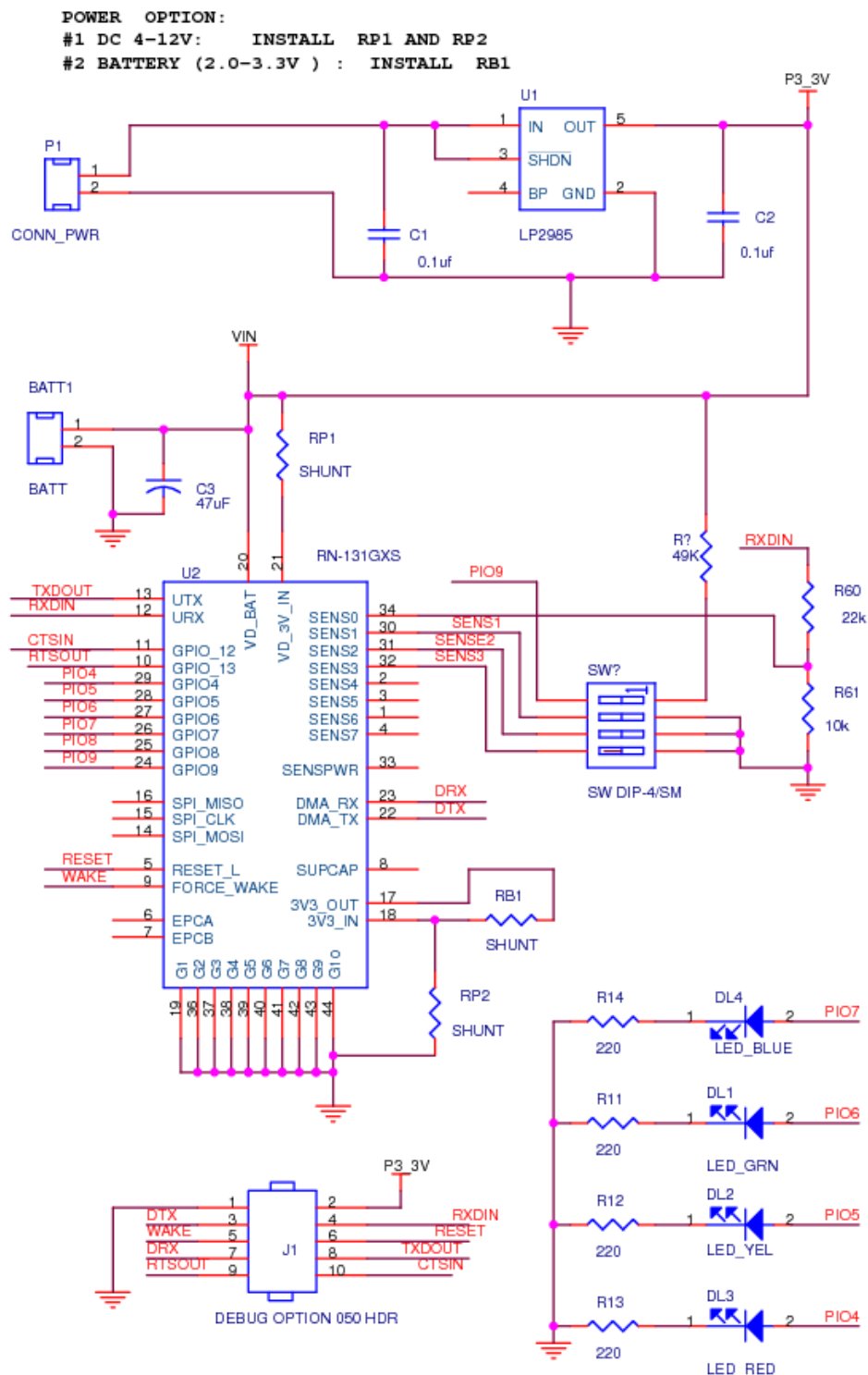

Pin Description

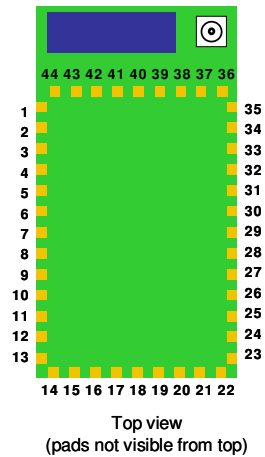

Pin	Name	Description	Default
1	SENSOR-6	Sensor interface, analog input to module, 1.2V	No connect
2	SENSOR-4	Sensor interface, Analog input to module, 1.2V	No connect
3	SENSOR-5	Sensor interface, Analog input to module, 1.2V	No connect
4	SENSOR-7	Analog input to module, 1.2V	No connect
5	RESET	Module reset, Active Low, reference to VDD-BATT, 160 min. pulse	Pull up
6	EPC-ANT-A	EPC port, RFID antenna A	No connect
7	EPC-ANT-B	EPC port, RFID antenna B	No connect
8	SUPERCAP	Balance center pin voltage on stacked super capacitors, Analog 3.3V	No connect
9	FORCE_AWAKE	Force the module to wakeup, input to module, 31us min. pulse	
10	GPIO-13	UART RTS flow control, 8mA drive, 3.3V tolerant	
11	GPIO-12	UART CTS flow control, 8mA drive, 3.3V tolerant	
12	UART-RX	RX to the module, 8mA drive, 3.3V tolerant	
13	UART-TX	TX from the module, 8mA drive, 3.3V tolerant	
14	SPI-MOSI	SPI master data out, module output, 8mA drive, 3.3V tolerant	
15	SPI-CLK	SPI clock, module output, 8mA drive, 3.3V tolerant	
16	SPI-MISO	SPI master data in, module input	
17	3.3V-REG-OUT	boost regulator control output, connect to 3.3V-REG-IN to enable	No connect
18	3.3V-REG-IN	boost regulator control input, connect to 3.3V-REG-OUT to enable	GND to disable
19	GND	Ground	
20	VDD-BATT	Battery input, 2.0-3.3V with boost regulator in use, 3.0-3.7V otherwise	
21	VDD-IN	3.3 to 3.7 voltage, do not connect when boost regulator is in use	
22	DMA-TX	Debug port	No connect
23	DMA-RX	Debug port	No connect
24	GPIO-9	Restore factory resets, 8mA drive, 3.3V tolerant	
25	GPIO-8	GPIO, 24mA drive, 3.3V tolerant	Weak pull down
26	GPIO-7	GPIO, 24mA drive, 3.3V tolerant	Weak pull down
27	GPIO-6	Association STATUS, 24mA drive, 3.3V tolerant	LED, Weak pull down
28	GPIO-5	Data transfer STATUS, 24mA drive, 3.3V tolerant	LED, Weak pull down
29	GPIO-4	Connection STATUS, 24mA drive, 3.3V tolerant	LED, Weak pull down
30	SENSOR-1	Sensor interface, analog input to module, 1.2V	
31	SENSOR-2	Sensor interface, analog input to module, 1.2V	
32	SENSOR-3	Sensor interface, analog input to module, 1.2V	
33	SENSE-PWR	Voltage output from module to power external sensors, 1.2-3.3V	
34	SENSOR-0	Wakeup from external condition	
35	NO CONNECT		No connect
36-44	GND	Must be connected for proper antenna performance	

Physical Dimensions

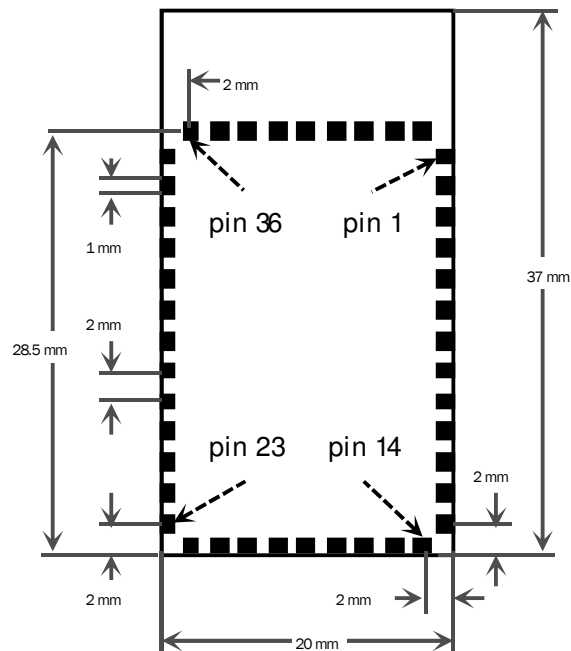
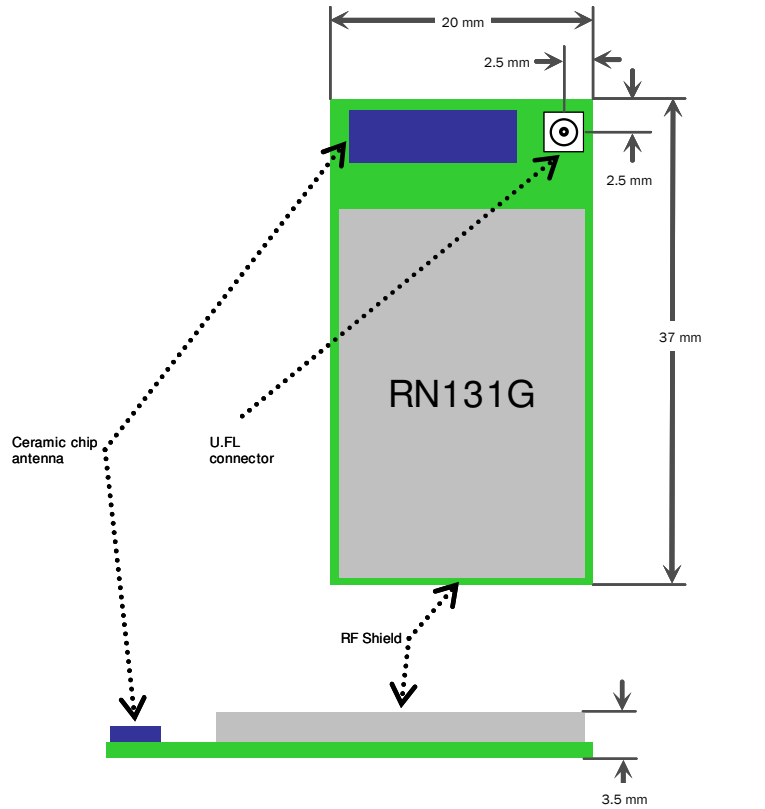

Bottom view

Design Concerns

1. **Minimizing Radio interference.** When integrating the WiFly module with on board chip antenna make sure the area around the chip antenna end the module protrudes at least 6mm from the mother board PCB and any metal enclosure. If this is not possible use the on board U.FL connector to route to an external Antenna.

The 8.5 mm area under the antenna end of the module should be keep clear of metallic components, connectors, vias, traces and other materials that can interfere with the antenna signal.

2. **Proper grounding.** For the module antenna to function pins 36- to 44 must be connected to GND. We suggest you place module such that 0.5mm of these pads is exposed. This provides access for soldering pins 36 through 44 from below and provides ample clearance of the antenna from the PCB.
3. **U.FL connector.** Use Hirose U.FL connector **U.FL-R-SMT** to for connecting external antennas. See Roving Networks U.FL to SMA cable. Part number: RN-UFL-SMA6

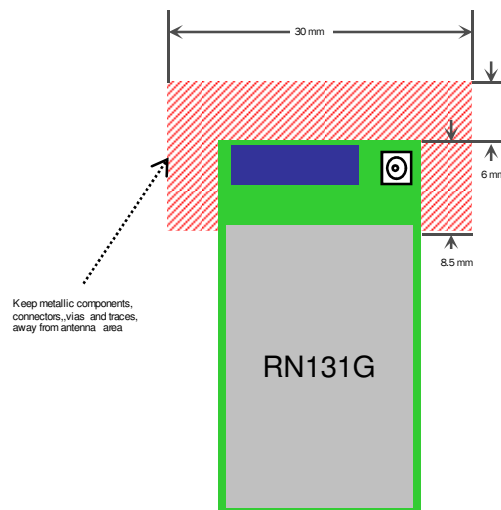

Top view

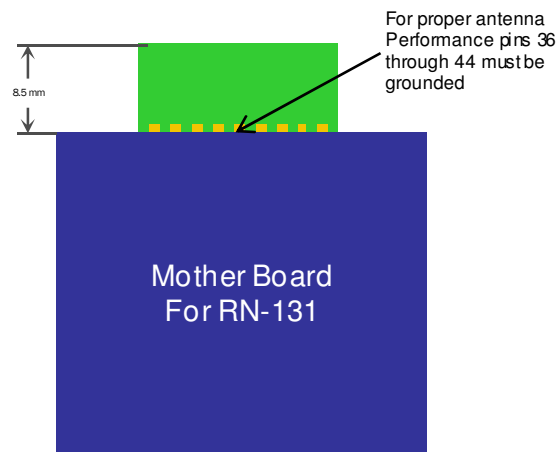
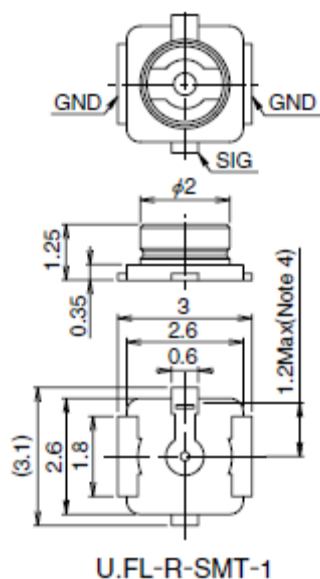

Bottom view

4. **Connection Status.** GPIO-4, GPIO-5, GPIO-6 are available to drive a status LEDs. GPIO-4 indicates connection status. When on this indicates an active connection, toggling fast indicates no IP address and toggling slow indicates IP address OK. GPIO-6 indicates association status. On means not associated with a network, Off indicates associated and Internet access is OK. GPIO-5 toggles when data is transferred. NOTE: If LEDs are not being drive by these signals
5. **Powering the module.** The WiFly module can be powered from either 3.0VDC batteries or 3.3VDC regulated power.

3.0VDC battery power

- Apply power to pin 20 (VDD-BATT)
- Short pin 17 (3.3V-REG-OUT) to pin 18 (3.3V-REG-IN)

3.3 VDC power

- Apply power to pin 20(VDD-BATT) and pin 21 (VDD-IN)
- Connect pin 18 (3.3V-REG-IN) to ground and leave pin 17 (3.3V-REG-OUT) un connected.

6. **Senor Interfaces.** Inputs must not exceed 1.2V. Sensitivity saturates at 400 mV.

7. **Restoring Factory Settings.** It is a good idea to connect pin 24, GPIO-9 to a switch or jumper connected to a pull up. Pulsing this signal high will RESTORE the initial module settings in cases where the module is mis-configured and no long responding.

Compliance Information

- FCC Certified for us in the United States and CE approved for use in Europe and other countries.
- Environmentally friendly RoHS compliant

Ordering Information

Part Number	Description
RN-131G	With chip antenna
RN-131G-EVAL	Development Kit for the RN-131G (Includes the RN-131G module)
RN-UFL-SMA6	6 inch cable with U.FL connector on one end and SMA on the other
For other configurations, contact Roving Networks directly.	

Visit <http://www.rovingnetworks.com> for current pricing and a list of distributors carrying our products.

Copyright © 2009 Roving Networks. All rights reserved.

Roving Networks reserves the right to make corrections, modifications, and other changes to its products, documentation and services at any time. Customers should obtain the latest relevant information before placing orders and should verify that such information is current and complete.

Roving Networks assumes no liability for applications assistance or customer product design. Customers are responsible for their products and applications using Roving Networks components. To minimize the risks associated with customer products and applications, customers should provide adequate design and operating safeguards.

Roving Networks products are not authorized for use in safety-critical applications (such as life support) where a failure of the Roving Networks product would reasonably be expected to cause severe personal injury or death, unless officers of the parties have executed an agreement specifically governing such use.

All other trademarks are property of their respective owners.