

Technical Information

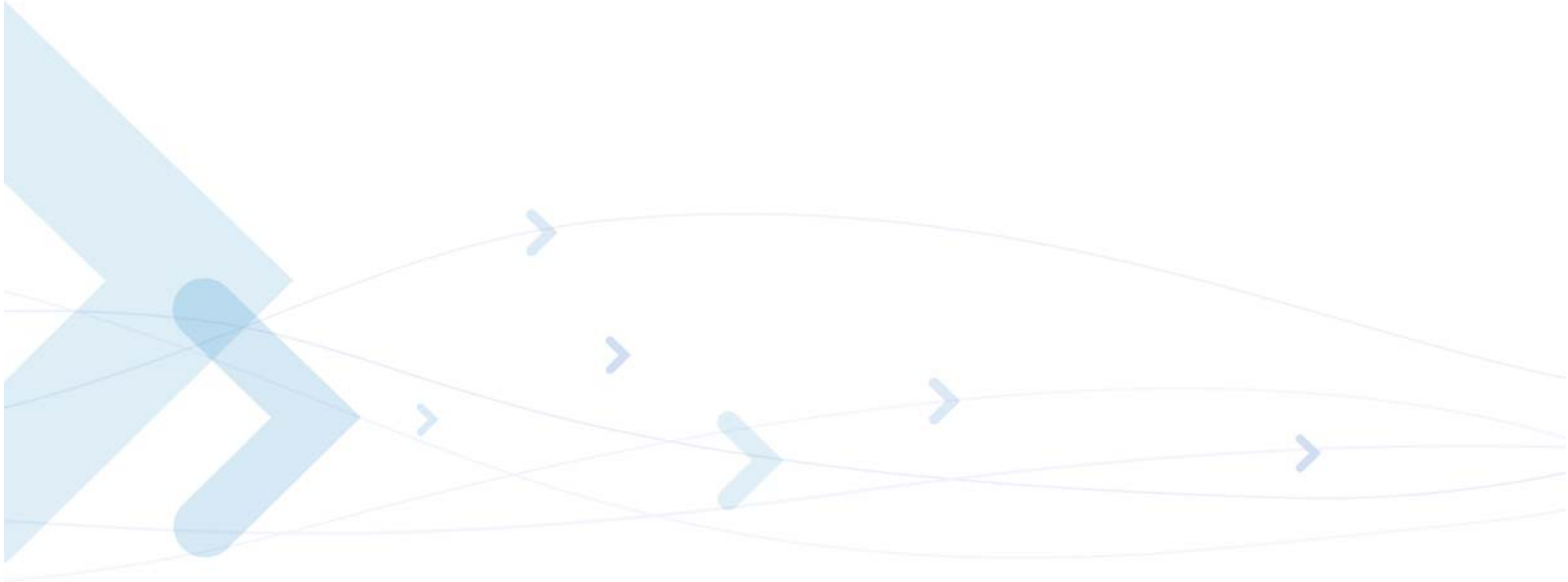

Motorola G24 KJAVA

User's Guide

JULY 15, 2008
6802981C50-D

SPECIFICATIONS SUBJECT TO CHANGE WITHOUT NOTICE

Notice

While reasonable efforts have been made to assure the accuracy of this document, Motorola, Inc. assumes no liability resulting from any inaccuracies or omissions in this document, or from use of the information obtained herein. The information in this document has been carefully checked and is believed to be entirely reliable. However, no responsibility is assumed for inaccuracies or omissions. Motorola, Inc. reserves the right to make changes to any products described herein and reserves the right to revise this document and to make changes from time to time in content hereof with no obligation to notify any person of revisions or changes. Motorola, Inc. does not assume any liability arising out of the application or use of any product, software, or circuit described herein; neither does it convey license under its patent rights or the rights of others.

It is possible that this publication may contain references to, or information about Motorola products (machines and programs), programming, or services that are not announced in your country. Such references or information must not be construed to mean that Motorola intends to announce such Motorola products, programming, or services in your country.

Copyrights

This instruction manual, and the Motorola products described in this instruction manual may be, include or describe copyrighted Motorola material, such as computer programs stored in semiconductor memories or other media. Laws in the United States and other countries preserve for Motorola and its licensors certain exclusive rights for copyrighted material, including the exclusive right to copy, reproduce in any form, distribute and make derivative works of the copyrighted material. Accordingly, any copyrighted material of Motorola and its licensors contained herein or in the Motorola products described in this instruction manual may not be copied, reproduced, distributed, merged or modified in any manner without the express written permission of Motorola. Furthermore, the purchase of Motorola products shall not be deemed to grant either directly or by implication, estoppel, or otherwise, any license under the copyrights, patents or patent applications of Motorola, as arises by operation of law in the sale of a product.

Computer Software Copyrights

The Motorola and 3rd Party supplied Software (SW) products described in this instruction manual may include copyrighted Motorola and other 3rd Party supplied computer programs stored in semiconductor memories or other media. Laws in the United States and other countries preserve for Motorola and other 3rd Party supplied SW certain exclusive rights for copyrighted computer programs, including the exclusive right to copy or reproduce in any form the copyrighted computer program. Accordingly, any copyrighted Motorola or other 3rd Party supplied SW computer programs contained in the Motorola products described in this instruction manual may not be copied (reverse engineered) or reproduced in any manner without the express written permission of Motorola or the 3rd Party SW supplier. Furthermore, the purchase of Motorola products shall not be deemed to grant either directly or by implication, estoppel, or otherwise, any license under the copyrights, patents or patent applications of Motorola or other 3rd Party supplied SW, except for the normal non-exclusive, royalty free license to use that arises by operation of law in the sale of a product.

VENDOR COPYRIGHT

Apache Software Foundation - Copyright 2004-2005 All Rights Reserved

Usage and Disclosure Restrictions

License Agreements

The software described in this document is the property of Motorola, Inc. and its licensors. It is furnished by express license agreement only and may be used only in accordance with the terms of such an agreement.

Copyrighted Materials

Software and documentation are copyrighted materials. Making unauthorized copies is prohibited by law. No part of the software or documentation may be reproduced, transmitted, transcribed, stored in a retrieval system, or translated into any language or computer language, in any form or by any means, without prior written permission of Motorola, Inc.

High Risk Materials

Components, units, or third-party products used in the product described herein are NOT fault-tolerant and are NOT designed, manufactured, or intended for use as on-line control equipment in the following hazardous environments requiring fail-safe controls: the operation of Nuclear Facilities, Aircraft Navigation or Aircraft Communication Systems, Air Traffic Control, Life Support, or Weapons Systems (High Risk Activities"). Motorola and its supplier(s) specifically disclaim any expressed or implied warranty of fitness for such High Risk Activities.

Trademarks



MOTOROLA and the Stylized M Logo are registered in the US Patent & Trademark Office. All other product or service names are the property of their respective owners.

©Copyright 2008 Motorola, Inc.

REV052604

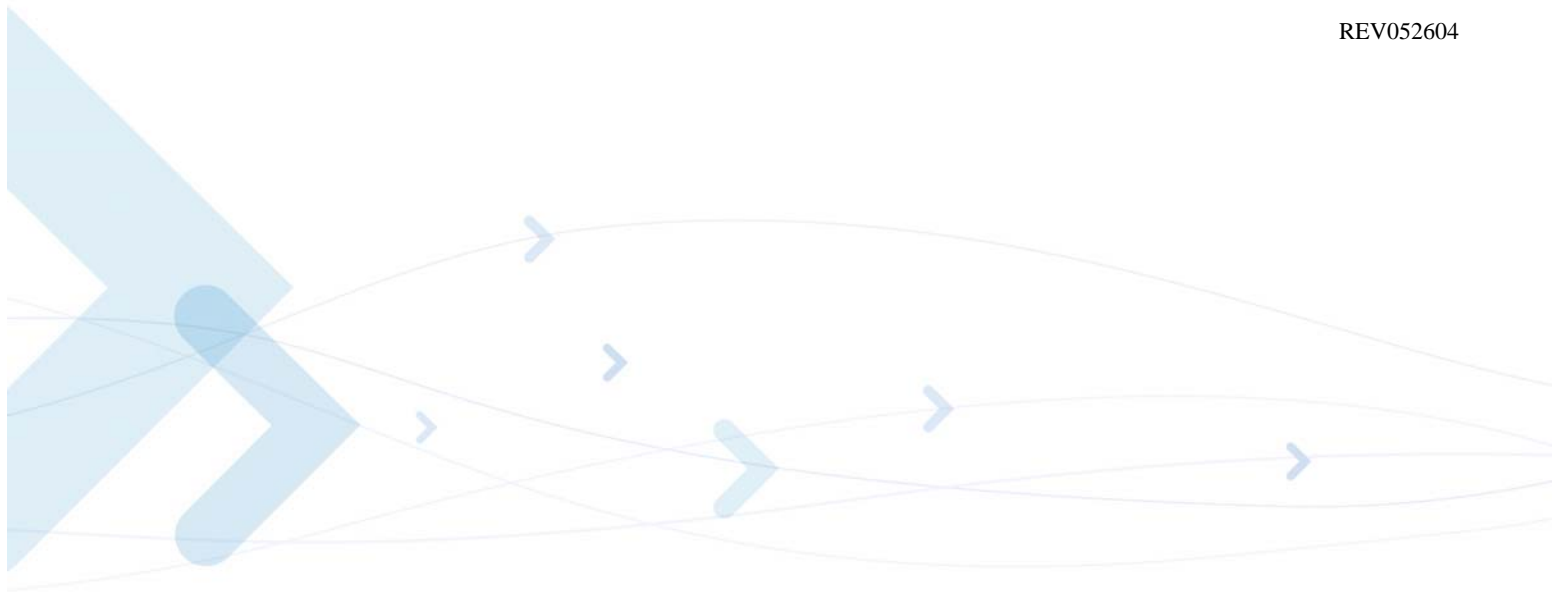

Manual Scopeix
Target Audienceix
Disclaimerix
Abbreviations, Acronyms And Definitions	x
Trademarksxi
Applicable Documentation	xii
Problem Reporting Instructions.....	xii
Manual Organization	xii
Text Conventions.....	xii
General Safety	xiii
Caring for the Environment.....	xiv
Revision Historyxvi
Chapter 1: Product Overview	1-1
Introduction	1-1
Product Advantages.....	1-3
Typical Use Case.....	1-3
Chapter 2: General Setup	2-1
Evaluation Board.....	2-1
Antenna Installation	2-2
Power Supply Installation	2-3
G24 EVB Placement	2-3
Start Operation	2-3
Software Configuration.....	2-4
Software Version	2-4
Available Memory	2-4
USB PC Driver	2-4
Default RS232 Configuration	2-4
Query System Information	2-4
MIDlet Downloading	2-5
Serial (UART2)	2-5
Over the Air	2-5
Common Errors	2-6
Reflashing G24 Software	2-6
G24-J HMI	2-6
Chapter 3: KJAVA Architecture	3-1
General.....	3-1
Functional Description	3-2
Switching between MIDlet Manager and JTool Manager without GPIO Pin Toggling	3-3
MIDlet Manager	3-4
JTool Manager.....	3-5
OEM Modes	3-6
MIDlet Security.....	3-8

Chapter 4: Development and Maintenance	4-1
General	4-1
JTool Commands	4-1
KDWP	4-4
Activation Procedure	4-4
Chapter 5: JAVA API	5-1
KJAVA Content	5-1
Packages Overview	5-2
Access Package	5-2
Network Package	5-2
OSC Package	5-3
OSC System Properties	5-4
Sleep Mode	5-4
Airplane Mode	5-5
Real Time Clock (RTC) Mechanism	5-5
Measurements	5-6
Antenna Presence	5-8
MIDlet Watchdog	5-8
WebSession Package	5-9
OTADownload	5-9
WebSessionManager	5-9
HAPI Package	5-11
GPIO API	5-11
A2D API	5-13
Call Package	5-14
I2C Package	5-14
IPD Package	5-16
IPD Connection Services	5-16
Standard Classes Deviations	5-17
Comm Connections	5-17
Server Socket Connection	5-17
Message Connection	5-19
File Connection	5-19
Location API	5-19
Connection of a GPS Device to G24-J	5-19
Initialization of a GPS Device	5-20
Setting of Selected G24-J UART Communication Properties for Location Session	5-20
Location Session	5-21
Appendix A: GPIO Lines	A-1
Appendix B: Default MIDlet Features	B-1
Supply Of All Available Unit Information	B-1
Fault Report	B-1
CQA Testing Routines Handler	B-2
OTA Provisioning	B-2
GPRS Indicator	B-2
SMS Updates / Requests Listener	B-3
Message Format	B-3

Messages Types	B-3
Java/MMS Session Update.	B-3
OTA (Over the Air) Download Trigger	B-5
Fault Report Addresses Update	B-6
Request for Fault Report	B-6
Ping.	B-7
Appendix C: GPIO Interrupt Latency	C-1
Introduction	C-1
Multithreading Background.	C-1
How To Achive Minimal Latency.	C-1
Code Example	C-2
Appendix D: MIDlet Signing	D-1
General.	D-1
Generic Signing.	D-1
Bound Signing.	D-1
Appendix E: IP Director	E-1
Using The IPD Feature	E-1
IPD Configuration	E-1
IPD Activation.	E-2
IPD Deactivation	E-3
OTA (Over The Air) Over Serial PPP Link	E-3

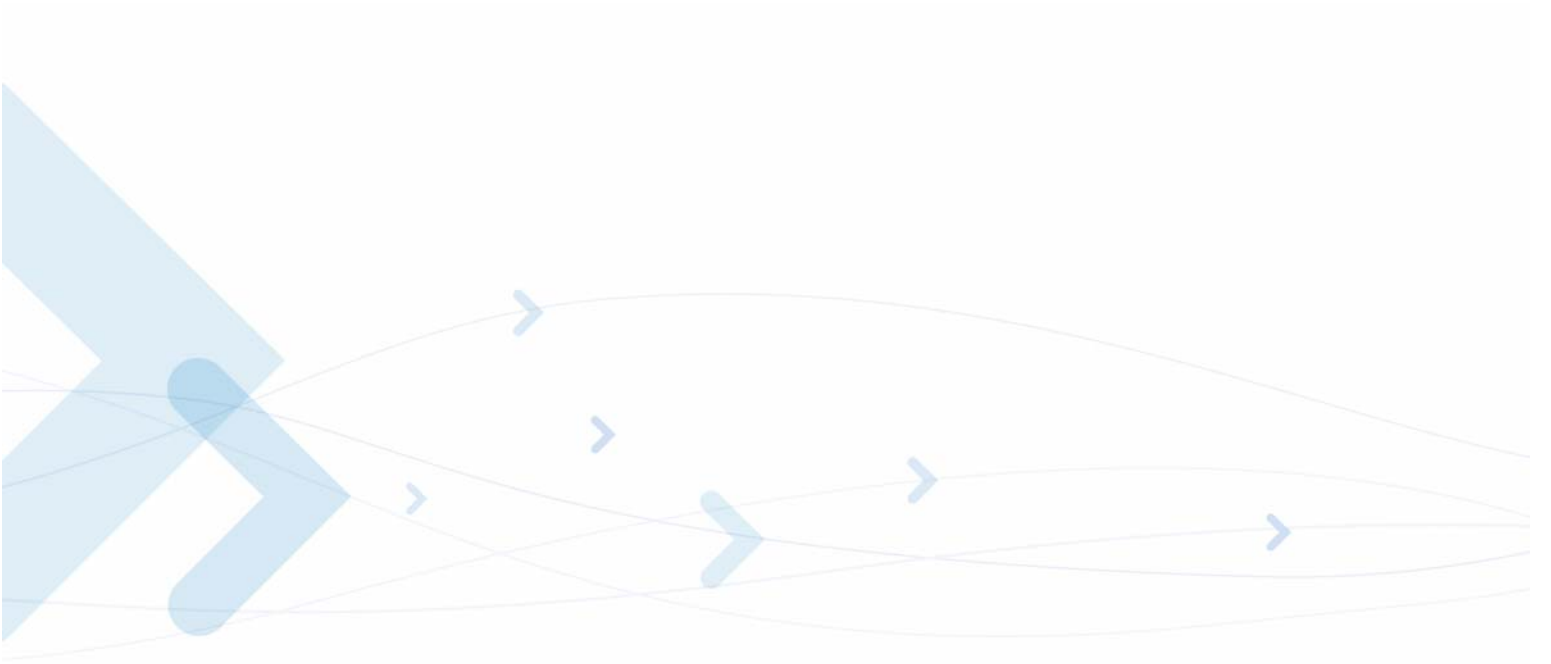

1-1	G24 - Basic Module Architecture	1-2
1-2	G24 - KJAVA Architecture	1-2
2-1	Evaluation Board - Major Components	2-1
3-1	G24 KJAVA Architecture	3-2
3-2	MIDlet Manager Flow	3-4
5-1	Actual Temperature Level (in degrees Celsius)	5-8
5-2	GPIO Counter Mechanism	5-12
5-3	Threshold's Conditions for Auto Notification by Threshold Mode	5-13
E-1	IPD Active	E-2
E-2	IPD Inactive	E-3

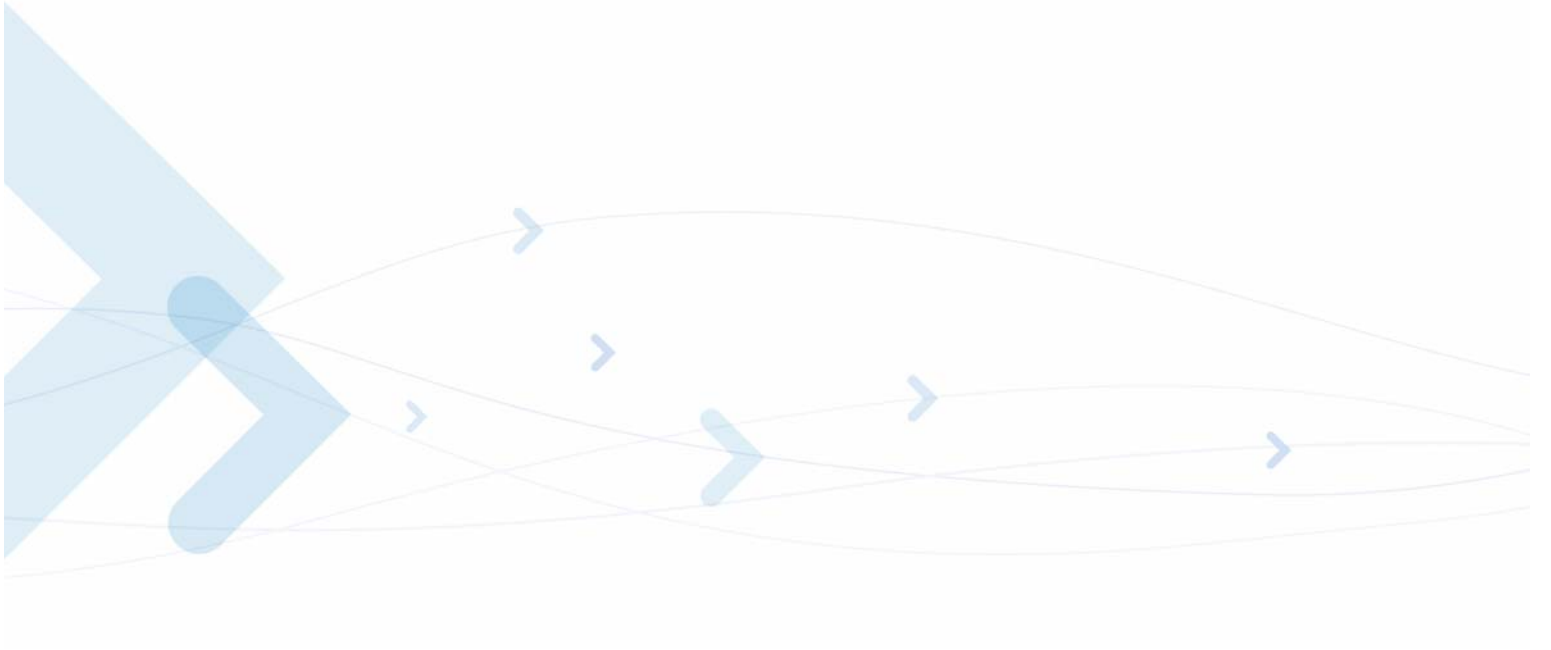

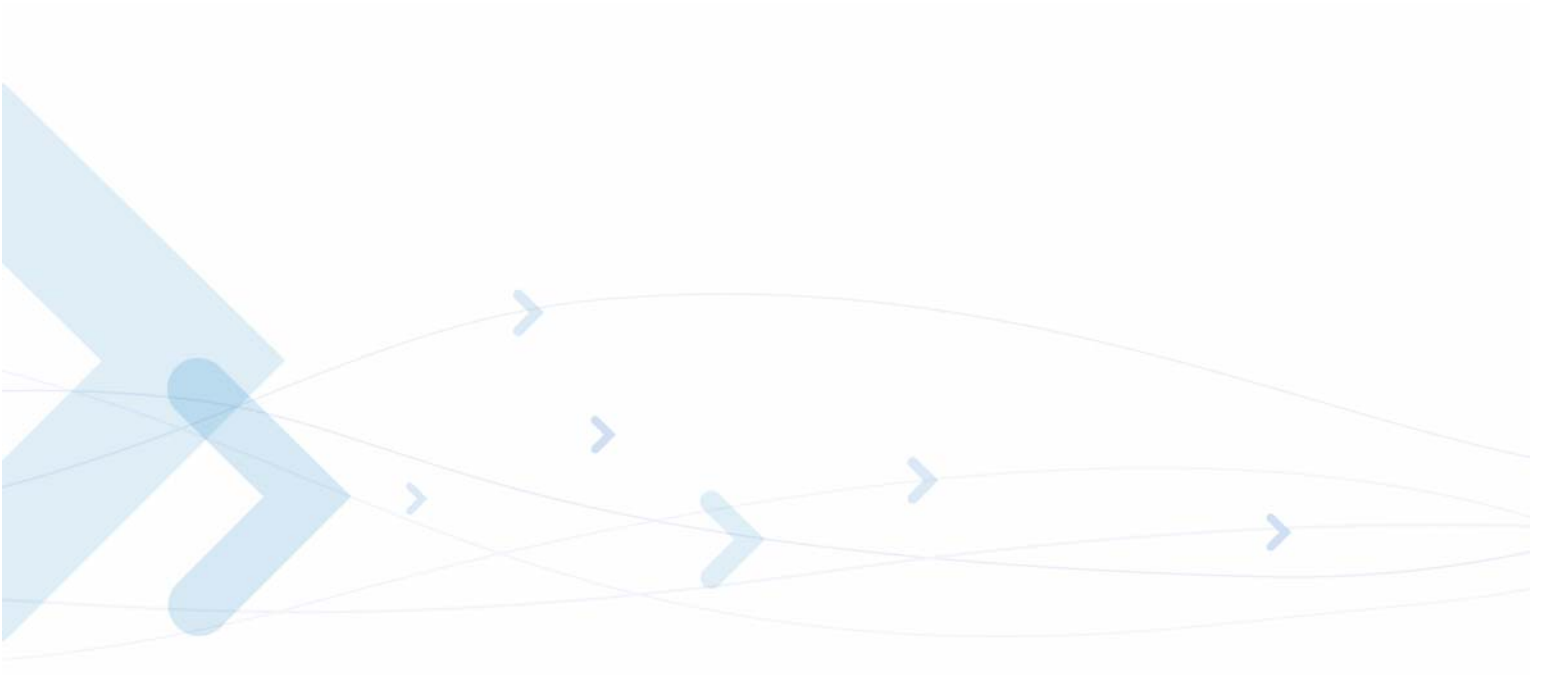

1-1	G24 Java Compared to a Handset.	1-1
2-1	Evaluation Board Description.	2-1
3-1	KMgr Pin	3-3
3-2	OEM Mode Settings	3-6
4-1	JTool Commands	4-1
5-1	Motorola API Matrix	5-1
5-2	OSC System Properties.	5-4
5-3	A/D Value to Temperature Conversion	5-7
5-4	Web Session Parameters.	5-10
5-5	Port to Serial Mapping	5-17
A-1	Java Module GPIO Lines, OEM Units.	A-1
A-2	Java Module GPIO Lines, HMI Units	A-2

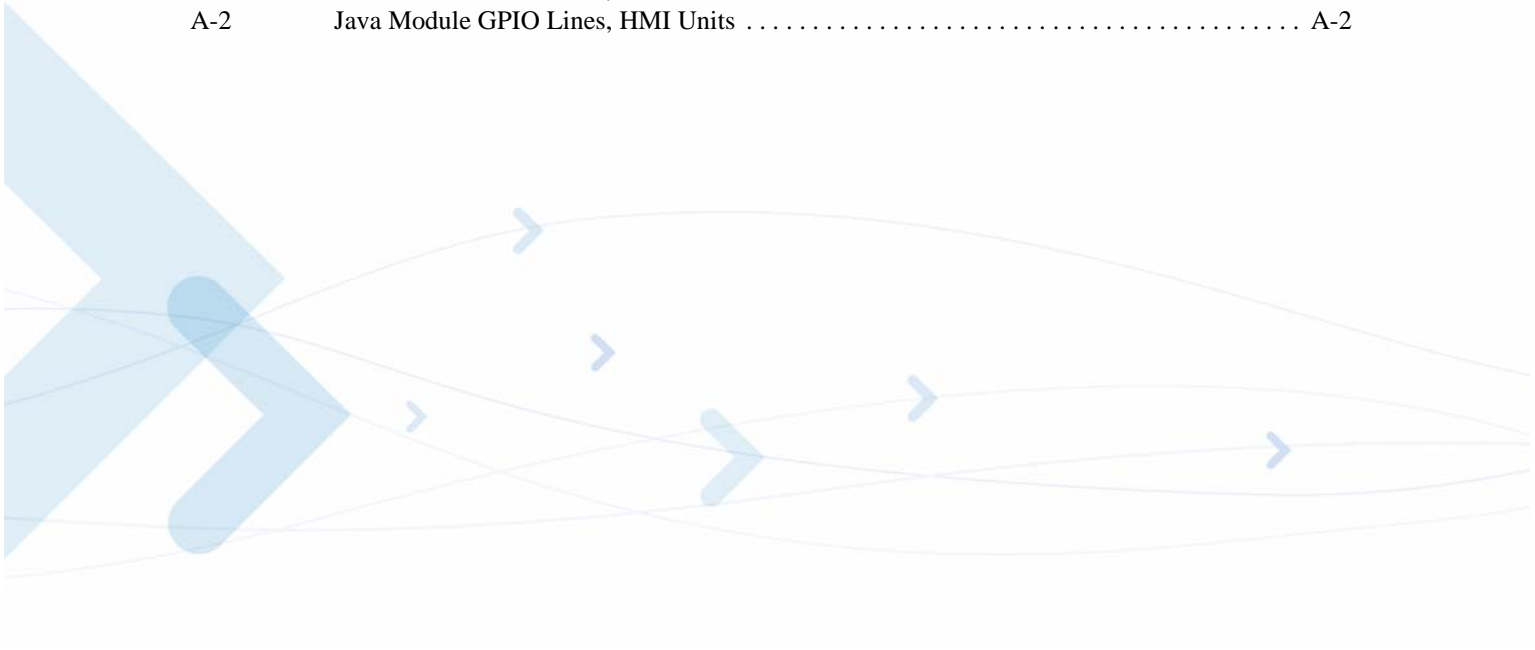

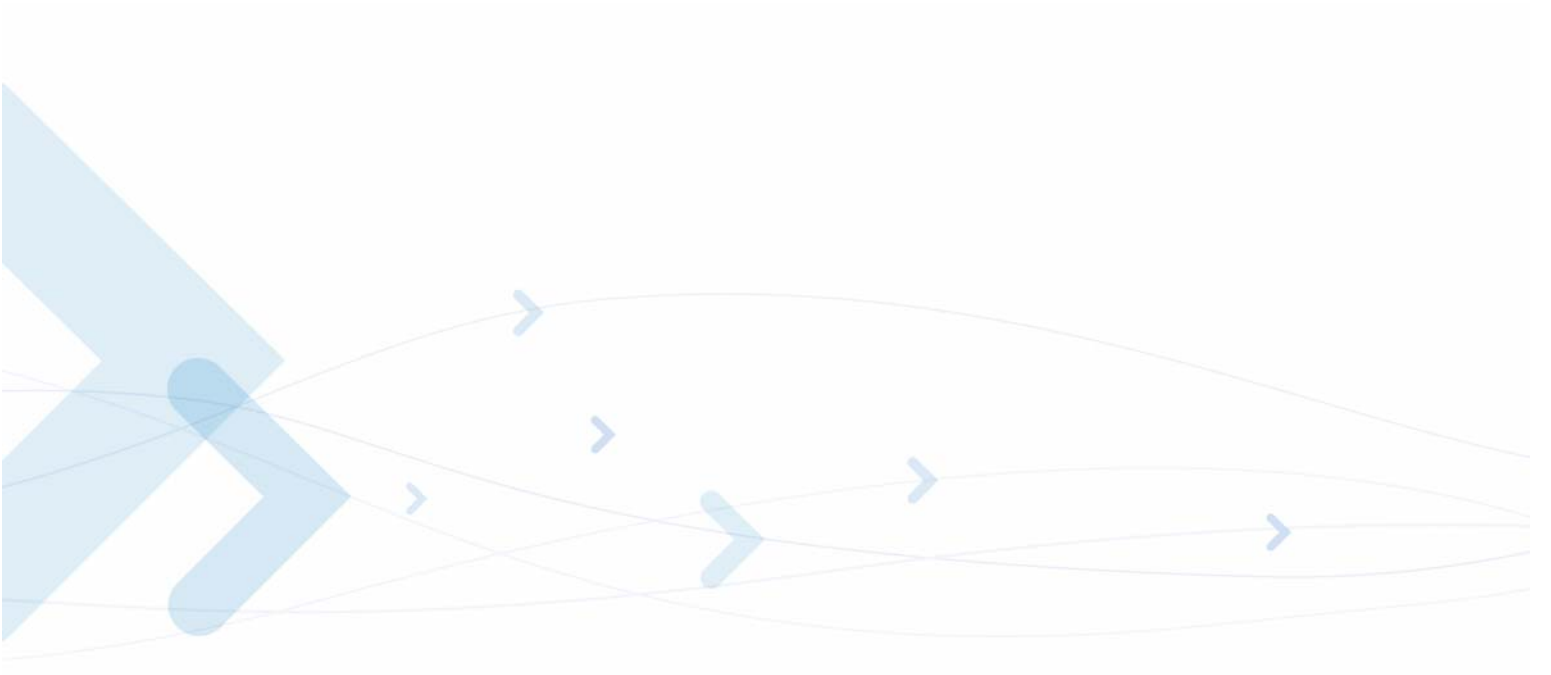

Preface

Manual Scope

This guide gives an overview of the G24 KJAVA product and its capabilities.

Target Audience

This guide is intended for G24 KJAVA customers, developers and support groups.

Disclaimer

Motorola reserves the right to make changes without notice to any of the products or services described herein. "Typical" parameters, which may be provided in Motorola Data sheets and/or specifications can and do vary in different applications and actual performance may vary. Customer's technical experts will validate all "Typicals" for each customer application.

Motorola makes no warranty in regard to the products or services contained herein. Implied warranties, including without limitation, the implied warranties of merchantability and fitness for a particular purpose, are given only if specifically required by applicable law. Otherwise, they are specifically excluded.

No warranty is made as to coverage, availability, or grade of service provided by the products or services, whether through a service provider or otherwise.

No warranty is made that the software will meet your requirements or will work in combination with any hardware or application software products provided by third parties, that the operation of the software products will be uninterrupted or error free, or that all defects in the software products will be corrected.

In no event shall Motorola be liable, whether in contract or tort (including negligence), for any damages resulting from use of a product or service described herein, or for any indirect, incidental, special or consequential damages of any kind, or loss of revenue or profits, loss of business, loss of information or data, or other financial loss arising out of or in connection with the ability or inability to use the Products, to the full extent these damages may be disclaimed by law.

Some states and other jurisdictions do not allow the exclusion or limitation of incidental or consequential damages, or limitation on the length of an implied warranty, therefore the above limitations or exclusions may not apply to you.

This warranty gives you specific legal rights, and you may also have other rights, which vary from jurisdiction to jurisdiction.

Motorola products or services are not designed, intended, or authorized for use as components in systems intended for surgical implant into the body, or other applications intended to support or sustain life, or for any other application in which the failure of the Motorola product or service could create a situation where personal injury or death may occur.

Should the buyer purchase or use Motorola products or services for any such unintended or unauthorized application, the buyer shall release, indemnify and hold Motorola and its officers, employees, subsidiaries, affiliates, and distributors harmless against all claims, costs, damages, and expenses, and reasonable attorney fees arising out of, directly or indirectly, any claim of personal injury or death associated with such unintended or unauthorized use, even if such claim alleges that Motorola was negligent regarding the designing or manufacturing of the product or service.

Motorola recommends that if you are not the author or creator of the graphics, video, or sound, you obtain sufficient license rights, including the rights under all patents, trademarks, trade names, copyrights, and other third party proprietary rights.

Abbreviations, Acronyms And Definitions

Abbreviation	Full Name
AMS	A pplication M anagement S oftware
APN	A ccess P oint N ame
Autoupdate	A user settable feature that synchronizes the local clock with the time received from the network
CPHS	C ommon P CN H andset S pecification
CSD	C ircuit S witch D ata
DM	D efault M IDlet
DNS	D omain N ame S erver
EVB	E valuation B oard
Flash	1. G24 software 2. The process of replacing the G24 software
Flex	G24 configuration file, allows product flexibility
GCF	G eneric C onnection F ramework
GIDx	Group Identifier level x
GPIO	G eneral P urpose I nput O utput
GPS	G lobal P ositioning S ystem
HAPI	H ardware A pplication P rogram I nterface
HMI	H uman M achine I nterface. G24 with display and keypad support
ICCID	I ntegrated C ircuit C ard I D
IDE	I ntegrated D evelopment E nvironment
IMEI	I nternational M obile E quipment I dentify
JAD	J ava A pplication D escriptor

Abbreviation	Full Name
JAR	<u>J</u> ava <u>A</u> rchive
JAL	<u>J</u> ava <u>A</u> pplication <u>L</u> oader
JPDA	<u>J</u> ava <u>P</u> latform <u>D</u> ebugger <u>A</u> rchitecture
KDWP	<u>K</u> VM <u>D</u> ebug <u>W</u> ire <u>P</u> rotocol
Kjava	<u>K</u> ilobyte Java
KMgr pin	<u>K</u> JAVA <u>M</u> anager GPIO pin
KVM	<u>K</u> ilobyte <u>VM</u> . Java VM for limited systems such as embedded ones
Local Clock	The unit's clock. This clock may be synchronized with the network or set by the user with the OSC class methods
M2M	<u>M</u> achine to <u>M</u> achine
MIDlet	An application that conforms to the MIDP standard.
MIDP	<u>M</u> obile <u>I</u> nformation <u>D</u> evice <u>P</u> rofile
MO	<u>M</u> obile <u>O</u> riginated
Motorola MD	Motorola <u>M</u> obile <u>D</u> evelopments Business
MT	<u>M</u> obile <u>T</u> erminated
NITZ	<u>N</u> etwork <u>I</u> dentify and <u>T</u> ime <u>Z</u> one
NMEA	<u>N</u> ational <u>M</u> arine <u>E</u> lectronics <u>A</u> ssociation
NVM	<u>N</u> on <u>V</u> olatile <u>M</u> emory
OEM	<u>O</u> riginal <u>E</u> quipment <u>M</u> anufacturer
OSC	<u>O</u> EM <u>S</u> ystem <u>C</u> ontrol
OTA	<u>O</u> ver <u>T</u> he <u>A</u> ir
OTA Provisioning	The process by which the carrier configures the device
PC	<u>P</u> ersonal <u>C</u> omputer
PCN	<u>P</u> ersonal <u>C</u> ommunication <u>N</u> etwork
PKI	<u>P</u> ublic <u>K</u> ey <u>I</u> nfrasturcture
RTC	<u>R</u> eal <u>T</u> ime <u>C</u> lock
TBD	<u>T</u> o <u>B</u> e <u>D</u> efined
SA	<u>S</u> hip <u>A</u> cceptance
SCL	<u>S</u> erial <u>C</u> lock line of I2C bus
SDA	<u>S</u> erial <u>D</u> ata line of I2C bus
UART	<u>U</u> niversal <u>A</u> synchronous <u>R</u> eceiver/ <u>T</u> ransmitter
UM	<u>U</u> ser <u>M</u> IDlet
URL	<u>U</u> niform <u>R</u> esource <u>L</u> ocator
USSD	<u>U</u> nstructured <u>S</u> upplementary <u>S</u> ervice <u>D</u> ata
Web Session	Holds Internet connection settings, also known as Internet Settings.
WS	<u>W</u> eb <u>S</u> ession

Trademarks

MOTOROLA and the Stylized M Logo are registered in the U.S. Patent and Trademark Office. All other product or service names are the property of their respective owners.

Applicable Documentation

- [1] Motorola G24 Developer's Guide, Module Hardware Description, at [G24-J MOTODEV Web Page](#)
- [2] Motorola G24 Developer's Guide, Developer's Kit, at [G24-J MOTODEV Web Page](#)
- [3] Motorola G24 Developer's Guide, AT Commands reference manual, at [G24-J MOTODEV Web Page](#)
- [4] [G24-J MOTODEV Web Page](#)
- [5] Motorola G24-J HMI Display Integration Guide, [G24-J MOTODEV Web Page](#)

Problem Reporting Instructions

Problems or corrections to this guide should be reported to G24 customer care by mail:
M2MCare@motorola.com

Manual Organization

This manual contains the following chapters:

- “Preface”
- **Chapter 1** - “Product Overview”
- **Chapter 2** - “General Setup”
- **Chapter 3** - “KJAVA Architecture”
- **Chapter 4** - “Development and Maintenance”
- **Chapter 5** - “JAVA API”
- **Appendix A** - “GPIO Lines”
- **Appendix B** - “Default MIDlet Features”
- **Appendix C** - “GPIO Interrupt Latency”
- **Appendix D** - “MIDlet Signing”
- **Appendix E** - “IP Director”

Text Conventions

The following special paragraphs are used in this guide to point out information that must be read. This information may be set-off from the surrounding text, but is always preceded by a bold title in capital letters:

Note

Note: Presents additional, helpful, noncritical information that you can use.

Warning

Warning: Presents information to warn you of a potentially hazardous situation in which there is a possibility of personal injury.

Important

Important: Presents information to help you avoid an undesirable situation or provides additional information to help you understand a topic or concept.

Caution

Caution: Presents information to identify a situation in which damage to software, stored data, or equipment could occur, thus avoiding the damage.



General Safety

Remember! . . . safety depends on you!

The following general safety precautions must be observed during all phases of operation, service, and repair of the equipment described in this manual. Failure to comply with these precautions or with specific warnings elsewhere in this manual violates safety standards of design, manufacture, and intended use of the equipment. Motorola, Inc. assumes no liability for the customer's failure to comply with these requirements. The safety precautions listed below represent warnings of certain dangers of which we are aware. You, as the user of this product, should follow these warnings and all other safety precautions necessary for the safe operation of the equipment in your operating environment.

Ground the instrument

To minimize shock hazard, the equipment chassis and enclosure must be connected to an electrical ground. If the equipment is supplied with a three-conductor AC power cable, the power cable must be either plugged into an approved three-contact electrical outlet or used with a three-contact to two-contact adapter. The three-contact to two-contact adapter must have the grounding wire (green) firmly connected to an electrical ground (safety ground) at the power outlet. The power jack and mating plug of the power cable must meet International Electrotechnical Commission (IEC) safety standards.

Note: Refer to "*Grounding Guideline for Cellular Radio Installations*"—Motorola part no. [68P081150E62](#).

Do not operate in an explosive atmosphere

Do not operate the equipment in the presence of flammable gases or fumes. Operation of any electrical equipment in such an environment constitutes a definite safety hazard.

Do not service or adjust alone

Do not attempt internal service or adjustment unless another person, capable of rendering first aid is present.

Keep away from live circuits

Operating personnel must:

- not remove equipment covers. Only Factory Authorized Service Personnel or other qualified maintenance personnel may remove equipment covers for internal subassembly, or component replacement, or any internal adjustment
- not replace components with power cable connected. Under certain conditions, dangerous voltages may exist even with the power cable removed
- always disconnect power and discharge circuits before touching them

Do not substitute parts or modify equipment

Because of the danger of introducing additional hazards, do not install substitute parts or perform any unauthorized modification of equipment. Contact Motorola Warranty and Repair for service and repair to ensure that safety features are maintained.

Dangerous procedure warnings

Warnings, such as the example below, precede potentially dangerous procedures throughout this manual. Instructions contained in the warnings must be followed. You should also employ all other safety precautions that you deem necessary for the operation of the equipment in your operating environment.

Warning example:

Warning: Dangerous voltages, capable of causing death, are present in this equipment. Use extreme caution when handling, testing, and adjusting.

Caring for the Environment

The following information is provided to enable regulatory compliance with the European Union (EU) Directive [2002/96/EC Waste Electrical and Electronic Equipment \(WEEE\)](#) when using Motorola equipment in EU countries.

Disposal of Motorola equipment in EU countries



Please do not dispose of Motorola equipment in landfill sites.

In the EU, Motorola in conjunction with a recycling partner will ensure that equipment is collected and recycled according to the requirements of EU environmental law.

Please contact the Customer Network Resolution Center (CNRC) for assistance. The 24 hour telephone numbers are listed at

<http://mynetworksupport.motorola.com>

Select **Customer Network Resolution Center contact information**.

Alternatively if you do not have access to CNRC or the internet, contact the Local Motorola Office.

Disposal of Motorola equipment in non-EU countries

In non-EU countries, dispose of Motorola Networks equipment in accordance with national and regional regulations.

The preceding states MOTOROLA's entire liability for MOTOROLA's breach or failure to perform under any provision of this Agreement.

Revision History

Manual Number

6802981C50-D

Manual Title

G24 KJAVA User's Guide

Version Information

The following table lists the manual version, date of version, and remarks about the version.

Revision History

Version	Date Issue	Remarks
A	May 15, 2007	Initial Release.
B	June 21, 2007	Updated due to software updates.
C	February 15, 2008	Appendix E added (IP Director) due to software updates. Additional minor updates.
D	July 15, 2008	Minor updates in Chapter 5 due to additional features.

Chapter 1: Product Overview

Introduction

G24 is a GSM/GPRS/EDGE OEM module. It is similar to a condensed cellular phone core, which can be integrated into a communication system to enable the transfer of voice or data information over a cellular network. For a detailed description of the G24 cellular engine refer to reference [1].

This OEM module which once was controlled by an external CPU is now enhanced to be controlled by the customer's java MIDlet applications running on G24's CPU. This new module name is OEM KJAVA.

The main Java differences between a mobile handset and G24 KJAVA engines are shown in Table 1-1.

Table 1-1: G24 Java Compared to a Handset

Handset	G24
Java is not the main feature.	Java controls all activities.
Activation via Menu by the user.	Activated automatically upon power-up.
MIDlet is for entertainment (Games, Calculators, ...).	MIDlet is a stand alone controller.

G24 KJAVA allows the customer MIDlet to control the following major features:

- Circuit Switched calls (data and voice)
- IP Network connections
- SMS/MMS
- GSM/GPRS Network status
- Serial connectivity
- SIM card
- NVM Data base (Phone book, File System, Record management)
- HW interfaces: A2D and GPIO
- Power (Low power mode, Airplane mode, Real Time Clock)
- MIDlet upgrade

Figure 1-1 and Figure 1-2 present the differences between basic module architecture and the KJAVA one:

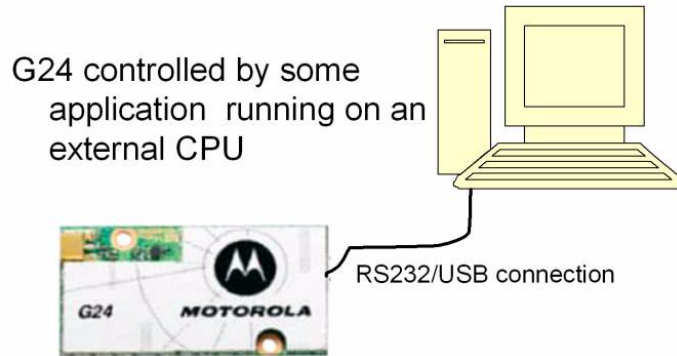

Figure 1-1: G24 - Basic Module Architecture

G24 controlled by an internal application, named MIDlet, running on G24 CPU

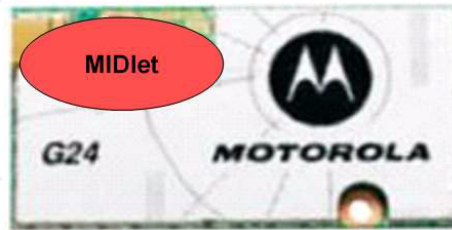

Figure 1-2: G24 - KJAVA Architecture

Two G24 hardware configurations are available:

- OEM - display and keypad are disabled
- HMI - display and keypad are enabled

Note: These two configurations look identical and can be identified by the model name printed on the units.

In order to facilitate G24's integration with external systems, an evaluation board (EVB) should be used. The EVB consist of the following features:

- 70 pin connector for G24 placement
- SIM card interface
- Antenna
- DC power supply
- USB and RS232 interfaces
- Digital and analog audio interfaces
- Switches, jumpers and LEDs for miscellaneous controls and indications

For a detailed description of the EVB, see “[Evaluation Board](#)” and reference [2].

A handset, display and keypad can be attached to the EVB. Such an EVB configuration requires the use of an HMI G24 unit.

Product Advantages

1. Cheaper & Simpler - No External CPU (the traditional controller).
 - Java MIDlet controls G24 functionality by running on its own CPU ("On target"), instead of using external controller CPU executing AT commands.
 - Smaller PCB.
2. Friendly & Flexible - Java Language has rich verity of standard cellular APIs.
3. Easy maintenance - Over The Air (OTA) customer MIDlet application upgrade.
4. Provides full Java solution -
New Motorola proprietary API - dedicated for the M2M market segment.
5. Partial mode - AT command mode running simultaneously with Java mode.
Example: Developers can use the G24 as a GPRS/EDGE module to connect to the internet via external TCP/IP stack (i.e. connect it to a standard computer dialer), on the other hand, in parallel, a Java MIDlet can be run.

Typical Use Case

A typical M2M use case can be described as follows:

G24 integrated within a vending machine, when the machine is out of products it toggles a G24 I/O pin which notifies the MIDlet (via G24 proprietary API). The MIDlet uses a standard SMS protocol (JSR 120) to notify a control center about this event.

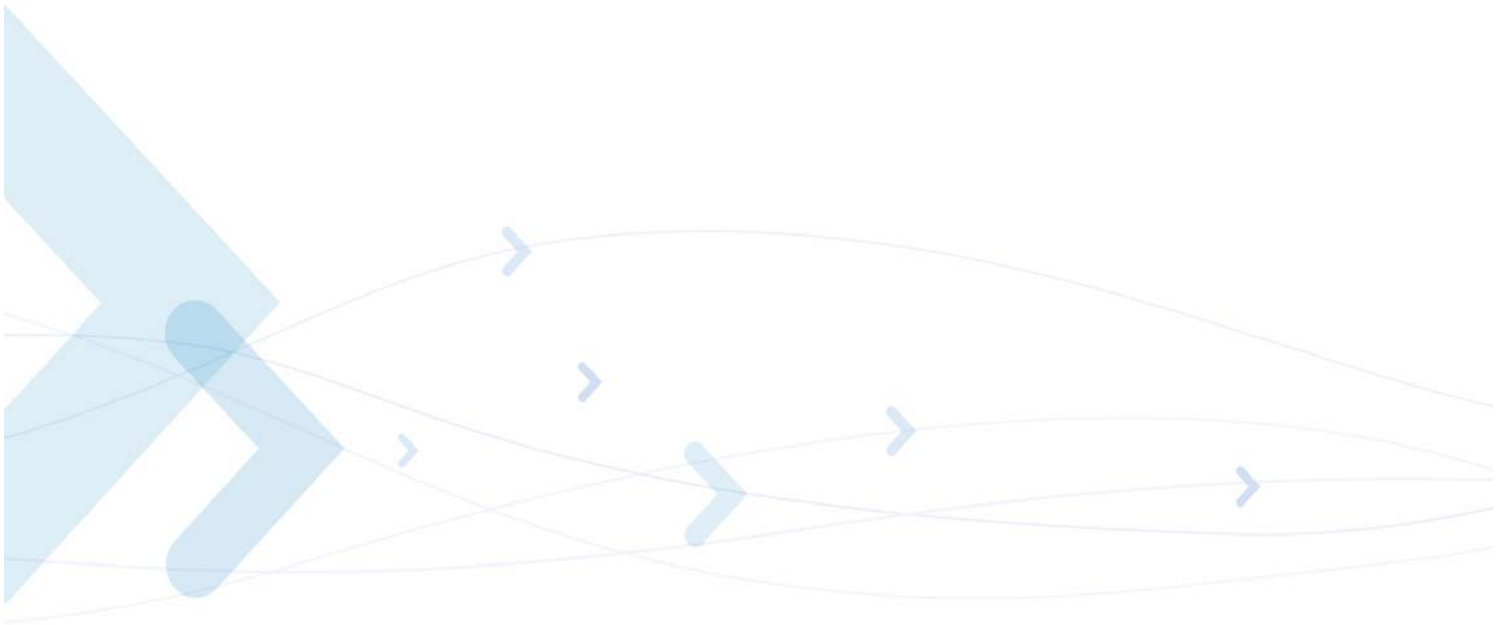

Chapter 2: General Setup

Evaluation Board

Figure 2-1 shows a G24 unit, display and SIM card mounted on the evaluation board (EVB) and other major EVB components. Table 2-1 gives a description of the components.

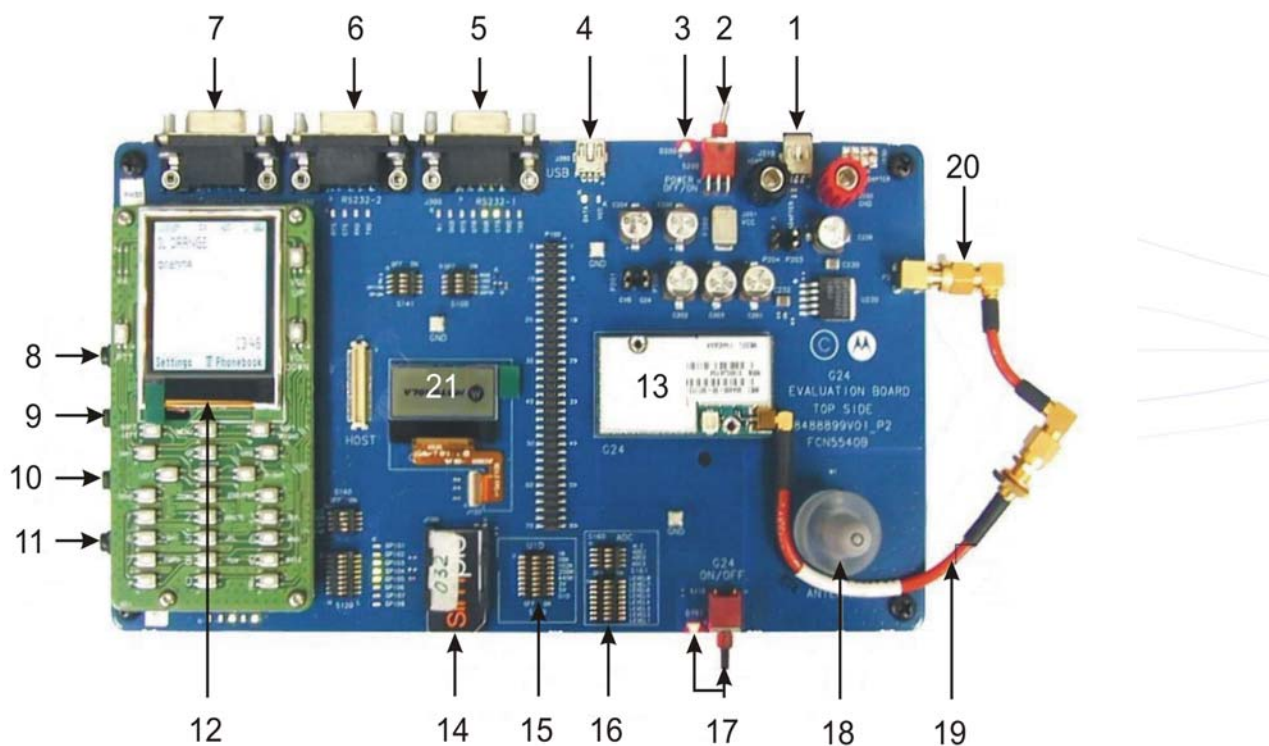

Figure 2-1: Evaluation Board - Major Components

Table 2-1: Evaluation Board Description

No.	Reference Designator	Description
1.	J210	Wall adapter supply connector
2.	S200	Main power supply switch

Table 2-1: Evaluation Board Description (Cont.)

No.	Reference Designator	Description
3.	D200	Main power supply indication LED
4.	J380	USB Mini-B Connector
5.	J300	RS232-1 Connector
6.	J330	RS232-2 Connector
7.	J350	RS232-3 Data Logger Connector
8.	J430	Speaker Connector
9.	J460	Microphone Connector
10.	J440	Headset Connector
11.	J480	Alert speaker Connector
12.	-	Keypad and Display
13.	-	G24
14.	J100	SIM card Tray
15.	S170	General switches for testing
16.	S160	General switches for A2D
17.	S110, D701	G24 On/Off push-button and indication LED
18.	M1	Antenna
19.	-	Antenna Cable
20.	P2	On board antenna connector
21.	J122	CLI Display

Antenna Installation

Note: The numbers in parenthesis refer to the numbers shown in [Figure 2-1](#).

1. Connect the supplied antenna stub to the EVB antenna base (18).
2. Connect the supplied antenna cable to the EVB SMA antenna connector (20).

Power Supply Installation

1. The supplied wall adapter includes a North-American type electrical plug, with optional adapter for European wall sockets. Connect the supplied wall adapter (1), or connect the power supply via the DC supply jacks.

- Note:**
- When using a DC supply, set its voltage level to 3.6V-4.2V, and its current limiting to 2.5A.
 - Use the power supply source selection jumper (P204 and P203) to activate either of the power supply sources.
 - Verify that P200, P201 jumpers are placed.

G24 EVB Placement

1. Position the G24 unit over its connector and align with the supporting spacers.
2. Use the supplied screws to fasten the G24 to the board spacers.
3. Connect the antenna cable to the G24 MMCX connector.

Start Operation

1. Turn-on the main power switch S200 (2), and verify that indication led D200 (3) is on. Led D701 (10) will turn-on briefly.
2. Turn on G24 by pressing the On/Off push-button switch (17) for a period of 1-2 seconds. Led D701 (17) will turn on permanently.
3. G24 is now ready.

Note: Turning on the ignition switch (IGN1 - S100) causes the unit to turn on automatically whenever the main power switch S200 (2) is turned on, skipping the On/Off push-button switch (17) press.

Software Configuration

G24 KJAVA has several GSM models available:

- Dual Band Europe
- Dual Band USA
- Quad Band
- Quad Edge

Software Version

User should use the following versions and up:

G24: G24_G_0C.11.B2R.

DM: DM_20_11_07.hs - version 2.2.3

Available Memory

Flash: 10 MB - Jar file and all data saved by MIDlet (RMS, File System).

RAM: 1.8 MB - Heap size.

USB PC Driver

USB PC driver can be found in:

http://developer.motorola.com/docstools/USB_Drivers/Handset_USB_Driver/

Default RS232 Configuration

Baud rate 19200bps, 8 data bits, 1 stop bit, no parity bit, Flow Control = HW (Auto CTS/RTS)

Query System Information

There are two ways to query for system information. The first one is by using DM default outputs upon its startup. Some of its outputs are:

- Software version
- Flex version
- DM version

The second way is by using OSC API via user own MIDlet. This can be done by using: OSC.getProperty method.

MIDlet Downloading

Serial (UART2)

Downloading a MIDlet via serial communications can be done using two different applications.

The first is a multipurpose tool developed alongside the G24, called "Jadpur".

The second is a Motorola Java loader application tool called "MIDway".

Both tools are available in MOTODEV website [4].

Jadpur Setup Stages:

Note: Jadpur requires MS .NET framework installed on your PC.

1. Connect G24 UART2 to PC COM via RS232 cable.
2. Switch the KMgr pin to JTool mode.
3. Run Jadpur, use the Ports button to select the desired COM port, and from "File"->Settings -> Communication menu option to configure the COM port baudrate to 19200 bps. In the Settings menu, check-mark the "One Click Download" option.
4. Use "File">"Open JAD" menu item to select the JAD file for download. JAD file properties will be displayed in the upper right corner window frame.
5. Click the Download button, located in the bottom toolbar, to send the oemdownload command and send JAD file.
6. MIDlet download and installation process reports are sent to terminal window, ending with "MIDlet installation completed".

MIDway Setup Stages:

1. Connect G24 UART2 to PC COM via RS232 cable.
2. Run MIDway and from "File"->Settings menu-> "Communication Settings" configure to 19200 bps. In the "AT command" box enter "OEMdownload" and click OK.
3. Switch the KMgr pin to JTool mode.
4. Select "File"->"Send AT command" menu item to send the download command to the device.
5. Select "File">"Open JAD" menu item to select JAD file.
6. Select "File">"Send JAD" menu item to send the JAD file (JAR file will be sent automatically).

Note: Using "AT command" box and "Debug Log" Tab in MIDway imitates the traditional terminal use. It is possible to work separately - sending JTool commands through external terminal and limiting the MIDway to handle the download process only.

Over the Air

Provides the ability to download and install content over a wireless network.

MIDlets stored on a web server can be downloaded to the unit in two ways:

1. Using the OTADownload API from a UM.

2. Triggering an OTA download from the DM.

Common Errors

1. Attributes common to JAR manifest and JAD are not identical.
2. The MIDlet-JAR-Size attribute field does not contain the correct JAR size in bytes.
3. Wrong JAD attributes:
MIDlet-Name must be "UserMIDlet" (case sensitive).
MicroEdition-Configuration should be CLDC-1.1.
MicroEdition-Profile must be MIDP-2.0.
4. Untrusted MIDlet trying to replace trusted MIDlet (resolution: trusted MIDlet must be deleted first).

Refer to "Motorola MIDway User's Guide" in the SDK documentation for additional information.

Reflashing G24 Software

G24 enables its own software upgrade. Upgrades can be done via:

1. USB with RSD tool.
2. UART1 with PCLoader tool ("OEMreflash" command must be issued via UART2 before using PCLoader).

For the above tools installation and user guides, contact customer care:

M2MCare@motorola.com

G24-J HMI

See reference document [5], G24-J HMI Display Integration Guide.

Chapter 3: KJAVA Architecture

General

The G24 KJAVA product runs one of the following two types of MIDlets:

User MIDlet (UM)

The UM is the customer's MIDlet which controls the G24 to its needs. The UM is the core concept within the G24 Java module. It lets the customers to run their own code on the G24's CPU. UM is expected to run "forever"

Note: MIDlet-Name attribute (in JAD file) must be "UserMIDlet" (case sensitive) and is verified during MIDlet installation (Any other name will cause the MIDlet to be rejected).

Default MIDlet (DM)

The DM is a MIDlet provided by the manufacturer. It is a backup MIDlet which enables basic control in case UM has failed or is absent (e.g. out of the factory). It also enables the customers to broadcast a command for a fresh UM download to all of their newly scattered units.

“[Default MIDlet Features](#)” describes all the DM's supported features.

Functional Description

G24 KJAVA module has three entities:

- **MIDlet Manager** - Manages and executes the MIDlet.
- **JTool Manager** - Manages G24 maintenance
 - JAL
 - G24 SW reflash
 - KDWP activation
 - Module configuration
- **OTA download Manager** - Over The Air MIDlet download procedure

The handshake between these three entities, controlling the G24, is shown in [Figure 3-1](#). These three entities are mutually exclusive, i.e. upon starting one of these entities the already running one will be stopped.

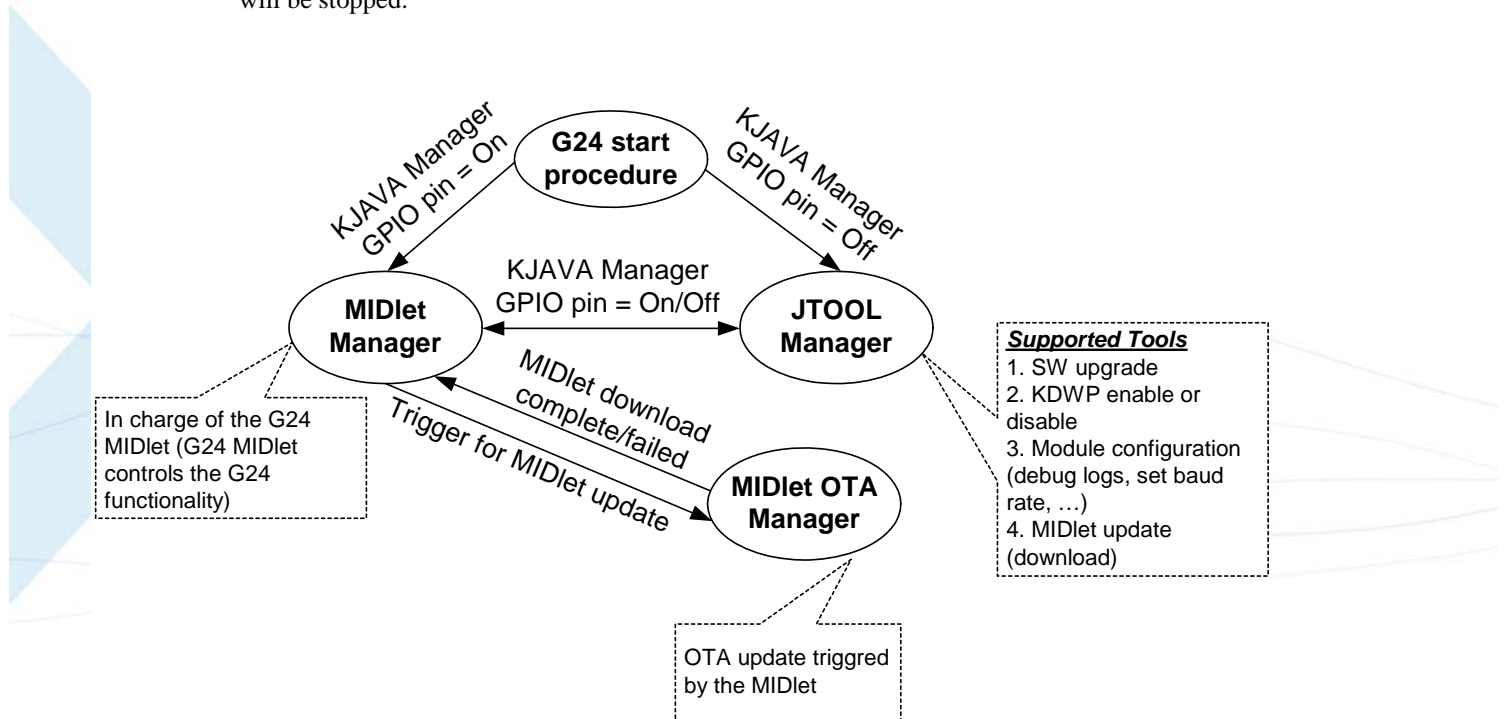

Figure 3-1: G24 KJAVA Architecture

A GPIO pin ("KMgr pin") selects between MIDlet Manager and JTool Manager entities.

Pin status and selection is defined as follows:

- OFF (low HW signal) - JTool Manager.
- ON (high HW signal) - MIDlet Manager.

Note: Line must be pulled to ON if not connected through a switch.

KMgr assigned pin depends on the hardware configuration (OEM or HMI) as described in [Table 3-1](#).

Table 3-1: KMgr Pin

G24 HW Type	Pin Number in 70 Pin Connector	GPIO Pin Name	EVb Switch
OEM	42	GPIO8	S120, GPIO8 reference
HMI	16	WKUPI_N/GPIO16	S100 WKUPI_N

Also refer to "[GPIO Lines](#)" and reference [2].

Switching between MIDlet Manager and JTool Manager without GPIO Pin Toggling

Switching between MIDlet Manager and JTool Manager can also be done using dedicated commands.

To switch from MIDlet Manager to JTool Manager - send the command "MMgr2JToolSwitch" over UART2 serial interface; G24 will send back 'JTOOL READY'.

The necessary pre-conditions for successful operation of the command are:

- MIDlet Manager is active
- KMgr pin is ON (in MIDlet Manger state)
- UART2 is not used by a MIDlet, KDWP or any other agent

If these pre-conditions are not met, the command will be ignored.

To switch from JTool Manager to MIDlet Manager, issue the command "JT2MM" in terminal.

The necessary pre-conditions for successful operation of the command are:

- JTool Manager is active
- KMgr pin is ON (in MIDlet Manger state)

If these pre-conditions are not met, the command will fail with JTool Error.

Note: This option is present mainly for easier production process. It allows scripts to download a MIDlet without the need to manually toggle the KMgr pin back and forth.

MIDlet Manager

The MIDlet Manager manages and executes the MIDlet. It is activated when KMgr pin is ON.

MIDlet Manager executes UM if it exists and valid, otherwise it executes the DM. In case DM is invalid too, MIDlet Manager will move to "Fault" state (reports can be observed via AMS logs mechanism) - waiting for MIDlet upgrade via JTool commands.

When MIDlet exits by invalid operations, it is marked with "Invalidity flag".

- **DM** - Flag is effective to the current session and will be cleared upon reset.
- **UM** - Flag is effective until UM upgrade (replacement).

Figure 3-2 demonstrates the MIDlet Manager flow:

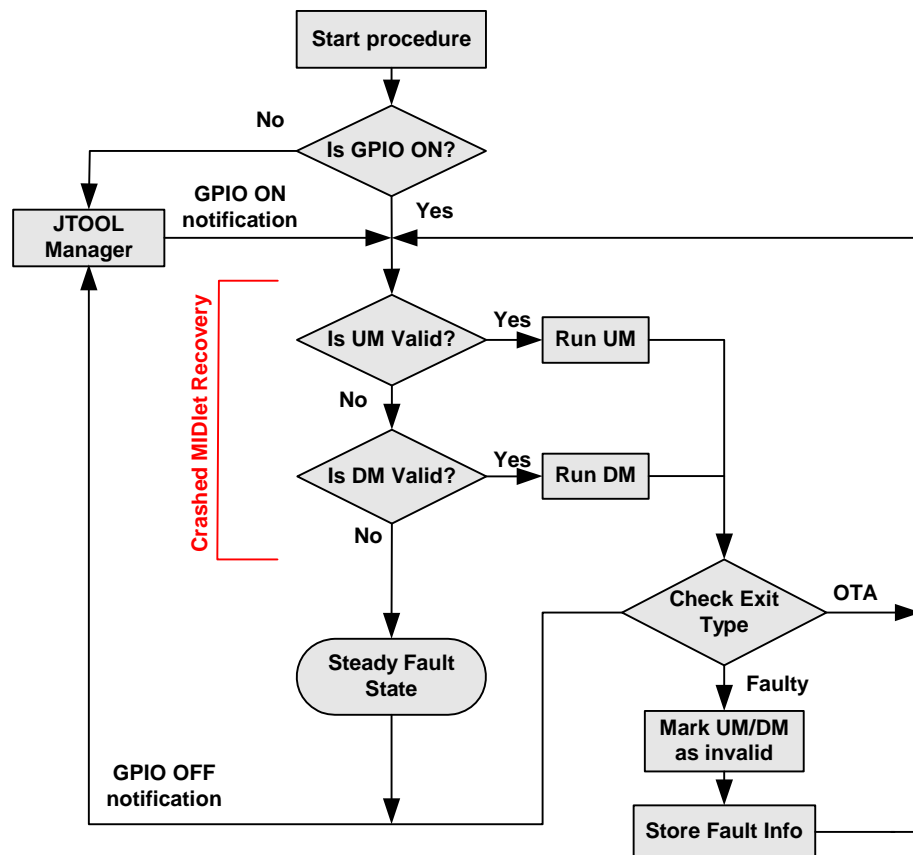

Figure 3-2: MIDlet Manager Flow

- Note:**
- Switching to JTool mode, OTA download and Shutdown (reset, watchdog expired, panic, ...) are considered valid exit operations.
 - Both UM and DM "invalidity flag" can be cleared using the JTool command: "OEMconfig_clearFlag", see [Table 4-1](#).
 - Run fault information can be accessed via `OSC.getProperty("oem.lastfault.running")` method.

JTool Manager

JTool Manager enables users to communicate with the G24 KJAVA module via RS232 over UART2 using a set of predefined commands (refer to “[Default RS232 Configuration](#)”).

JTool Manager functionality:

1. Downloading a MIDlet via Jadpur or MIDway.
2. Reflashing of G24 software.
3. KDWP activation.
4. Module configuration.

Default RS232 configuration:

Baud Rate = Default baud rate (value 19200 bps);

Data Bits = 8 bit;

Parity = NONE;

Stop Bits = ONE STOP BIT;

Flow Control = HW (Auto CTS/RTS)

See “[JTool Commands](#)” section for more details

OEM Modes

The G24 unit has three functional modes (OEM modes):

1. Java - Only MIDlet controls the unit.
2. Partial Java - The unit is controlled by MIDlet and a limited set of AT commands.
3. AT - Only AT commands control the unit (KJAVA module is disabled).

OEM modes can be controlled by the OSC class.

For OEM mode settings see [Table 3-2](#).

Table 3-2: OEM Mode Settings

OEM Mode	API	Connectivity availability
JAVA	OSC.setProperty("oem.mode", "java_mode")	KJAVA controls: UART1, UART2, USB
Partial JAVA 1	OSC.setProperty("oem.mode","partial_java_mode_1")	KJAVA controls: UART2 AT Commands via: UART1, USB
Partial JAVA 2	OSC.setProperty("oem.mode","partial_java_mode_2")	KJAVA controls: UART2, USB AT Commands via: UART1
Partial JAVA 3	OSC.setProperty("oem.mode","partial_java_mode_3")	KJAVA controls: UART1, UART2 AT Commands via: USB
AT Mode	OSC.setProperty("oem.mode", "AT_mode")	AT Commands via: UART1, UART2, USB

In order to read the OEM mode use - OSC.getProperty("oem.mode").

Mode switching between AT mode and JAVA mode without Java APIs:

- JTool command - "OEMconfig_java2at" for AT mode.
- AT command - "AT+MJAVA=0" for JAVA mode.

- Note:**
- Upon changing the OEM mode, G24 performs power cycle.
 - Use AT+MJAVA? Command to query current OEM mode.

Partial Java Mode

In this mode, KJAVA is available in parallel with the AT commands as in Table 4.

The main purpose of this mode is to allow External GPRS call while KJAVA is active; however more commands are available.

When developing in such mutual environment it is important to avoid addressing the same platform resource. In such cases inconsistencies and failures may occur.

The main problematic components are blocked to AT commands in this mode and are listed in the following lists.

There are two types of commands. "Type 1" consists of permanently blocked commands and "Type 2" consists of configurable blocked commands (can be reconfigured to be unblocked). Configuration is done on the entire list and by Motorola only.

Type 1

CHLD, CHUP, CR, A, D (except for D*99), DL, H, CACM, CAMM, CAOC, CPAS, CPUC, CSNS, CTFR1, MCST, MIPCALL, MIOD, MIOC, MMAD

Type 2

CFUN, CCLK, ATS24, CPBS, CPBR, CPBF, CPBW, MCSN, MDSI, CSVM, MPDPM, CPIN, CPWD, CLCK, EMPC, COPS, CLIP, CLIR, CUSD, CCWA, COLP, CALM, CLVL, CMUT, CRSL, CRTT, MADIGITAL, MAFEAT, MAMUT, MAPATH, MAVOL, MMICG, MPCMC, VTD, VTS, S94, S96, CNMA, CNMI, CSCB, MCSAT



MIDlet Security

This paragraph describes the MIDP 2.0 Security Model for the Motorola G24 KJAVA product.

Two types of MIDlets can be downloaded into the G24: “Untrusted” (Unsigned) or “Trusted” (Signed).

Security modes:

MIDlet may run in one of two security modes:

- Normal mode (Trusted domain) - Full access is granted to all APIs
- Safe mode (Untrusted domain) - Limited access to API.
Any access to a protected API will be blocked and an exception will be thrown (java.lang.SecurityException).

Mode is determined according to MIDlet JAD during the download process. Signed MIDlet will run at Normal mode, Unsigned will run in Safe mode.

G24 uses x.509 PKI for signing and verifying trusted MIDlets.

The JAD file of a signed MIDlet contains additional attributes:

- MIDlet-JAR-RSA-SHA1
- MIDlet-Permissions
- MIDlet-Certificate-1-1

The protected APIs are:

- javax.microedition.io.HttpConnection
- javax.microedition.io.HttpsConnection
- javax.microedition.io.DatagramConnection
- javax.microedition.io.SocketConnection
- javax.microedition.io.SecureConnection
- javax.microedition.io.ServerSocketConnection
- javax.wireless.messaging.*
- com.motorola.oem.OTADownload
- com.motorola.oem.call.*

Note: Download process will fail in case of signature error.

See “[MIDlet Signing](#)” for additional information.

Chapter 4: Development and Maintenance

General

The following log types are available:

AMS logs - Issued by unit components (AMS, KVM, and Native Code)

MIDlet logs - Issued by running MIDlet (stdout)

JTool Commands

JTool commands enable external communication to G24 KJAVA module over serial connection (See “[JTool Manager](#)” section for more information).

When switching to JTool, running MIDlet is stopped.

A command line consists of JTool command string and a carriage return (commands are not case sensitive):

<Command><CR>

G24 KJAVA module echoes the input to the terminal.

The G24 KJAVA JTool commands are listed in [Table 4-1](#).

Table 4-1: JTool Commands

Subject	JTool commands	Action	Notes
JTool	JT	Returns "JTool OK" when alive and listening.	
Download	OEMdownload	Prepares the unit for downloading a MIDlet.	
Reflash	OEMreflash	Switch to boot mode - ready for reflash.	Only for UART1 with PCLoader tool.
KDWP	OEMkdwpON	Sets KDWP flag 'ON'.	KDWP flag is checked when running a MIDlet. If it is 'on' then the MIDlet will run in debug mode.
	OEMkdwpOFF	Sets KDWP flag 'OFF' (future use).	

Table 4-1: JTool Commands (Cont.)

Subject	JTool commands	Action	Notes
UART's Baud Rate	OEMconfig_BaudRead: <u>X</u>	Read baud rate for serial <u>X</u>	<p><u>X</u> values: '1' - UART1 '2' - UART2</p> <p><u>Y</u> ranges: 9600, 19200, 38400, 57600, 115200</p> <p>Note: When JTOOL is activated UART2 is set to "Default baud rate".</p>
	OEMconfig_BaudDefaultSet: <u>X</u> , <u>Y</u>	Set default baud rate <u>Y</u> for UART <u>X</u>	
	OEMconfig_BaudDefaultRestore: <u>X</u>	Restore default baud rate for UART <u>X</u>	
	OEMconfig_BaudSet: <u>X</u> , <u>Y</u>	Set baud rate <u>Y</u> for UART <u>X</u> for the current session.	
Log Routing	OEMconfig_LogRead	Read log routing	<p><u>X</u> values: '0' - USB '1' - UART1 '2' - UART2</p> <p>Logs are routed to UART2 by default. Only one log type to one port</p> <p><u>Y</u> values: '0' - AMS '1' - STDOUT</p>
	OEMconfig_LogSet: <u>X</u> , <u>Y</u>	Route to serial <u>X</u> log type <u>Y</u>	
Log	OEMconfig_LogEnable: <u>X</u>	Enable Logs	<p><u>X</u> values: '0' - AMS '1' - STDOUT</p> <p>Note: Disabling "AMS logs" will cause them to be routed to platform data logger.</p>
	OEMconfig_LogDisable: <u>X</u>	Disable Logs	
Trace	OEMconfig_TraceEnable: <u>X</u>	Enable Trace	<p><u>X</u> values: 1-n, when n is the number of available traces types.</p> <p>Note: Traces are subcategories of AMS logs.</p>
	OEMconfig_TraceDisable: <u>X</u>	Disable Trace	
	OEMconfig_TraceEnableAll	Enable All Traces	
	OEMconfig_TraceDisableAll	Disable All Traces	
	OEMconfig_TraceRead	Outputs all available traces with their number and current status	
Java to AT Mode	OEMconfig_java2at	Change OEM mode from Java mode to full AT mode	<p>Note: Unit will reset before the change takes place.</p> <p>For switching back to Java: AT+MJAVA=0</p>

Table 4-1: JTool Commands (Cont.)

Subject	JTool commands	Action	Notes
Clear invalidity flag	OEMconfig_clearFlag:UM	Clear UM invalidity flag (for debug purposes)	See see“KJAVA Architecture” for additional information.
	OEMconfig_clearFlag:DM	Clear DM invalidity flag (for debug purposes)	
Delete MIDlet	OEMconfig_delete:UM	Delete UM	

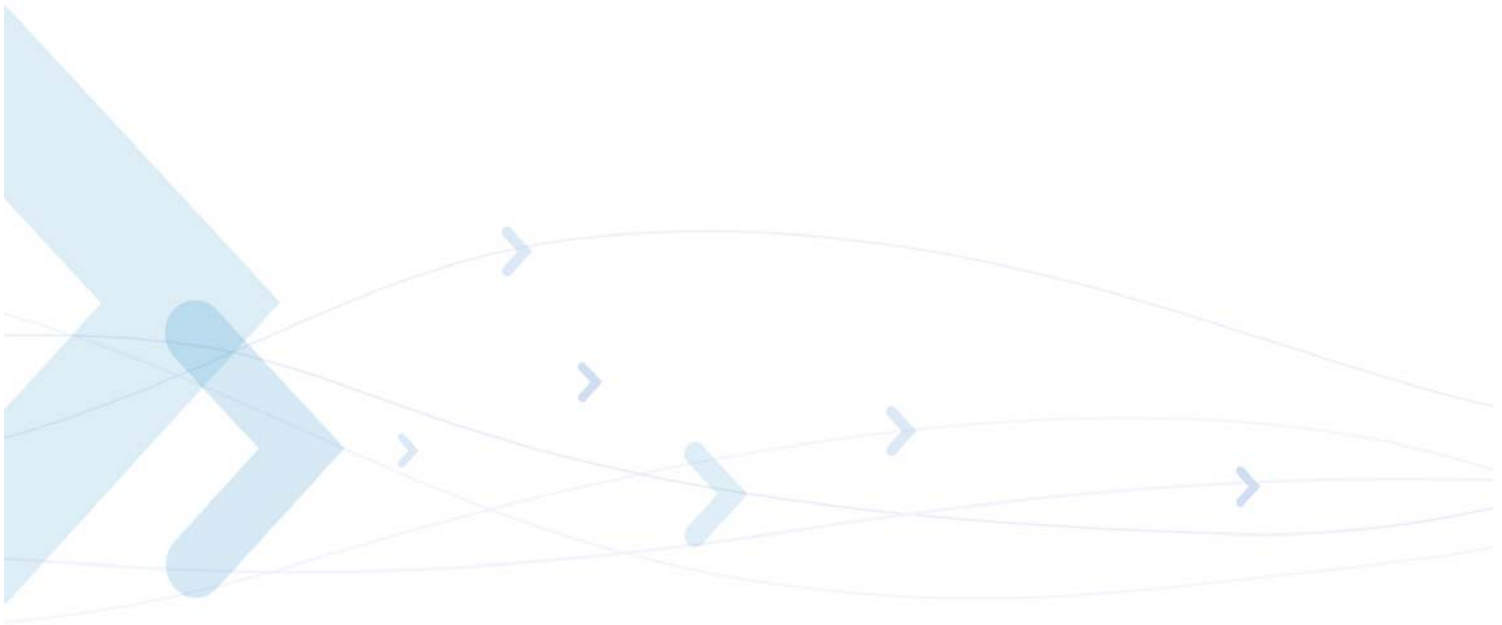

KDWP

KDWP is used for MIDlet "on target" debugging. Its "Debug agent" (PC application) communicates with the target's KVM over RS232 (A serial connection must be set between G24 UART2 and PC COM). Only UART2 can be used, therefore Serial Logs should be routed to UART1, USB or disabled.

IDE application must be JPDA (Java Platform Debugger Architecture) compliant to be able to attach to "Debug agent". Known JPDA compliant IDEs are: NetBeans, Eclipse and JBuilder.

All KDWP relevant files (including detailed activation procedure) can be found in the related bundle located in MOTODEV website, see reference [\[4\]](#).

- Note:**
- MIDlet must be compiled with debug information.
 - After restart KDWP is off.

Activation Procedure

1. Switch to JTool.
2. Enable KDWP on unit ("OEMkdwpon" command).
3. Set UART2's baud rate to 115200.
4. Switch to MIDlet Manager.
5. Execute the following command on a PC (in KDWP folder):

```
java -jar kdp.jar -v 9 -r serial: <com_port_number> -l <debugger_port_number> -cp <classes>
```

 - **com_port_number** - port number on PC
 - **debugger_port_number** - port to be used by IDE debugger
 - **classes** - semicolon separated files with classes to debug including MIDlet's JAR file.

Note: MIDlet JAR file must be in KDWP folder.

Example:

```
java -jar kdp.jar -v 9 -r serial: 1 -l 1234 -cp WSupdata.jar
```

6. Start IDE and set breakpoints as needed.
7. Attach debugger to IDE.
Note that IDE should attach to the same port number as in <debugger_port_number>.
8. In order to quit KDWP G24 should be restarted (restarting will take ~30 seconds).

Chapter 5: JAVA API

KJAVA Content

The APIs available in G24 KJAVA product are listed in [Table 5-1](#).

Table 5-1: Motorola API Matrix

G24 APIs	Description	JSR's	API Type
CLDC 1.1	Infrastructure	139	Standard
MIDP 2.0	UI, RMS, Connections, Basic Audio	118	
COMM Connection	Logical serial port connection		
WMA 1.1/2.0	SMS, MMS	120,205	
MMAPI 1.1	Audio record play, video playback	135	
PIM	Contacts Access	75	
File Connection	File system access	75	
Location	Request and get location result	179	
Access	SIM card services access	N/A	Motorola Proprietary
HAPI	GPIO and A2D control	N/A	
Network	Manage network features	N/A	
OSC	OEM system control services	N/A	
Websession	Manage websession services	N/A	
Call	Handle MO and MT call operations	N/A	
I2C	Manage I2C communication	N/A	
IPD	Utilize the IP Director feature	N/A	

Packages Overview

For detailed package usage information refer to Javadoc.

Access Package

Package name: com.motorola.oem.access

The Access package provides these SIM card services:

1. SIM card status: indication and query.
2. SIM PIN1:
 - Lock utility - enable/disable and query status
 - Unlock
 - Change Code

- Note:**
- Enabling/ Disabling Lock utility will take effect after next power cycle.
 - Unlocking is valid until next power cycle.
 - Code change can be done only when Lock utility is enabled and SIM PIN1 is unlocked.
 - 3 times wrong PIN1 entry will cause SIM to be blocked.
3. Get MSISDN phone numbers.
 4. Get SIM card files data (IMSI, GID1, GID2, CPHS, ICCID, and Preferred Languages).

Network Package

Package name: com.motorola.oem.network

The Network package provides these network (GSM/GPRS) features:

1. Network related indications and query:
 - Signal strength (RSSI and BER)
 - Cell information
 - Registration status
2. Operator selection.
3. Query of available networks.
4. Edit the preferred operators list.
5. Network Clock (NITZ) - format "yyyy/mm/dd,hh:mm:ss+timezone" (time zone is presented in units of quarter hour). Availability depends on network operator. See [“OSC Package”](#).
6. GPRS service attach and detach.
7. Jamming detection.
8. Supplementary services (SS):
 - Calling line ID (CLI) presentation
 - Calling line ID (CLI) restriction

USSD - Unstructured reports are supported - String representing the network indication or confirmation.

Some network indication response require user's action (example: password for barring).

For each transaction response a required-action code will be attached.

Possible action codes:

- Further user action required - session continues, the MIDlet should follow with a new MO transaction.
- No action needed - session is closed.

Some indications, sent by the network are Network Initiated messages.

USSD service restrictions:

- Network query operations (including a second USSD transaction) will be restricted when USSD transaction is taking place
- USSD transaction will be restricted when Network query operations are taking place.
- USSD String length will be at most 200 characters
- Sending an Empty string will result in session termination.
- The option to cancel a session after starting a transaction is not supported.

For more details refer to - G24-J Java Doc.

OSC Package

Package name: com.motorola.oem.osc

The OSC class provides:

- “get” and “set” methods to access system properties
- Enable sleep mode
- SW Reset
- Power down
- Get Power-up reason
- Real time clock mechanism
- Measurements indication and query:
 - Battery level
 - G24 internal temperature
 - Antenna
- Air plane mode - RF disable
- MIDlet Watchdog
- The DisplayConfig class provides:
 - FPGA & Display configuration

OSC System Properties

The OSC system properties are listed in [Table 5-2](#).

Table 5-2: OSC System Properties

Property name	Description	Possible values	Default value	Available for get/set method
oem.lastfault.running	UM/DM Last run fault information.	NA	NA	Get
oem.lastfault.panic	Last panic information.	NA	NA	Get
oem.lastfault.ota	Last OTA fault information.	NA	NA	Get
oem.lastfault.reportaddressX	Report destination address (X: 1 to 3).	Refer to “APPENDIX B - DEFAULT MIDlet FEATURES”	NA	Set, get
oem.logs.ams.available oem.logs.stdout.available	AMS logs Standard output logs	ON, OFF	ON	Set, get
oem.logs.ams.route oem.logs.stdout.route	Serial port for log	USB, UART1, UART2	UART2	Set, get
oem.mode	Java or AT operation mode	See Table 3-2	NA	Set, get
oem.dm.smslistener	DM SMS Listener	ON, OFF	ON	Set, get
oem.dm.updateurl	Update URL for download the dm	NA	NA	Set, get
oem.audio.digital	Audio to be used: digital or analog	ON, OFF	ON	Set, get
oem.hw.module	Hardware configuration	OEM, HMI	NA	Get
oem.hw.imei	Product IMEI	NA	NA	Get
oem.version.software	Software version	NA	NA	Get
oem.version.flex	Flex Version	NA	NA	Get
oem.version.dm	DM version number	NA	NA	Get
oem.version.um	UM version number	NA	NA	Get
oem.kmgrpin.timesample	Kmgr pin time sample. Valid for the next power cycle. See “ Sleep Mode ” for more details.	"disable"->0ms ->0.5ms "level2" ->5 ms "level3" -> 10 ms "level4" ->20 ms	"level1"	Set, get

Sleep Mode

G24 will enter sleep mode once it is **enabled** and **idle** state is reached (no I/O interrupts and RF activities).

Unit current consumption while in sleep mode is 3.5mA @ DRX9.

- Note:**
- USB device connected to G24 will prevent unit from entering sleep mode.
 - If data (Serial Logs or Comm Connection) is not being read by external device (remains in UART1 or UART2 buffers) G24 will not enter Sleep Mode.
 - To reduce power consumption to minimum, Kmgr pin time sample (polling) should be reduced respectively. Use `setProperty("oem.kmgrpin.timesample",XXX)`.

Airplane Mode

When "Airplane" mode is turned on, all transmit and receive RF circuits are disabled and Network related classes will throw an exception, if accessed:

- `SocketConnection`
- `UDPDatagramConnection`
- `SocketServerConnection`
- `HTTPConnection`

After power cycle, G24 restarts in normal mode, i.e. RF operations are enabled, even if in the previous session they were closed.

Real Time Clock (RTC) Mechanism

The RTC mechanism consists of two parts:

1. "Time and Date" - contains current date and time synchronized with Network time.
2. "Alarm" - contains some pre-installed date and time.

The RTC mechanism operates in all of the G24 KJAVA operating modes (Off, Idle, Sleep) as long as the power supplied is above the minimum operating level, see reference [1]. If the power supply is physically disconnected from the G24, the RTC timer resets and all the time, date and alarm settings are lost. On the next G24 power-up the time and date will revert to a default value.

The currently default is "00:00:00 01-Feb-07" (This value may be changed in further versions).

Time and Date

The OSC class provides the ability for the UM to accept or to decline Network NITZ update.

There are two ways to set "Time and Date" to be available:

- By auto update - if network supports NITZ and UM enables this feature.
- Direct set - if UM disables auto update and manually set Time and Date.

After power cut "time and date" will be reset and not be available until next set.

If network does not support Network NITZ update it is recommended not to enable auto update.

Alarm

Enable the user to set a time for an Alarm event to occur. This event will take place when "Time and Date" becomes equal to Alarm's setting time.

This feature can be used to automatically switch the module ON at a pre-defined time (can be used to save battery power).

Measurements

The G24 KJAVA module supports measurements of antenna presence, battery level and temperature.

Battery

All available range of battery voltage - from 3200 mV to 4200 mV is broken on pre-defined levels according to the table below:

Level	Battery Voltage
5	3700 - 4200
4	3500 - 3700
3	3400 - 3500
2	3350 - 3400
1	3300 - 3350
0	3200 - 3300 (Low battery)

Notification will be sent if average value of battery voltage crosses to new range.

Temperature

Temperature measurement is mapped from 0-255 A2D units to Celsius.

The actual temperature level (in degrees Celsius) can be derived from table or graphical representation (see [Table 5-3](#) or [Figure 5-1](#))

Table 5-3: A/D Value to Temperature Conversion

Temperature (°C)	A2D units	Temperature (°C)	A2D units	Temperature (°C)	A2D units
-30	229	4	114	38	43
-29	226	5	111	39	41
-28	223	6	108	40	40
-27	219	7	105	41	39
-26	216	8	102	42	38
-25	213	9	100	43	37
-24	210	10	97	44	36
-23	206	11	94	45	34
-22	203	12	92	46	33
-21	199	13	89	47	32
-20	196	14	87	48	31
-19	192	15	84	49	31
-18	189	16	82	50	30
-17	185	17	79	51	29
-16	182	18	77	52	28
-15	178	19	75	53	27
-14	175	20	73	54	26
-13	171	21	71	55	26
-12	168	22	69	56	25
-11	164	23	67	57	24
-10	160	24	65	58	23
-9	157	25	63	59	23
-8	153	26	61	60	22
-7	150	27	59	61	21
-6	146	28	57	62	21
-5	143	29	56	63	20
-4	140	30	54	64	20
-3	136	31	52	65	19
-2	133	32	51	66	19
-1	130	33	49	67	18
0	127	34	48	68	18
1	123	35	47	69	17
2	120	36	45	70	17
3	117	37	44		

A temperature level approximation can be obtained using the following 5th order polynomial formula:

$$\text{Temp [C]} = A5 * \text{ADCp5} + A4 * \text{ADCp4} + A3 * \text{ADCp3} + A2 * \text{ADCp2} + A1 * \text{ADCp1} + A0$$

A5 = -1.3e-09, A4=8.91591e-07, A3=-0.00024, A2=0.032894, A1=-2.56084, A0=103.2997

- ADCpN means ADC value powered by N
- XeY means X*(10 powered by Y)

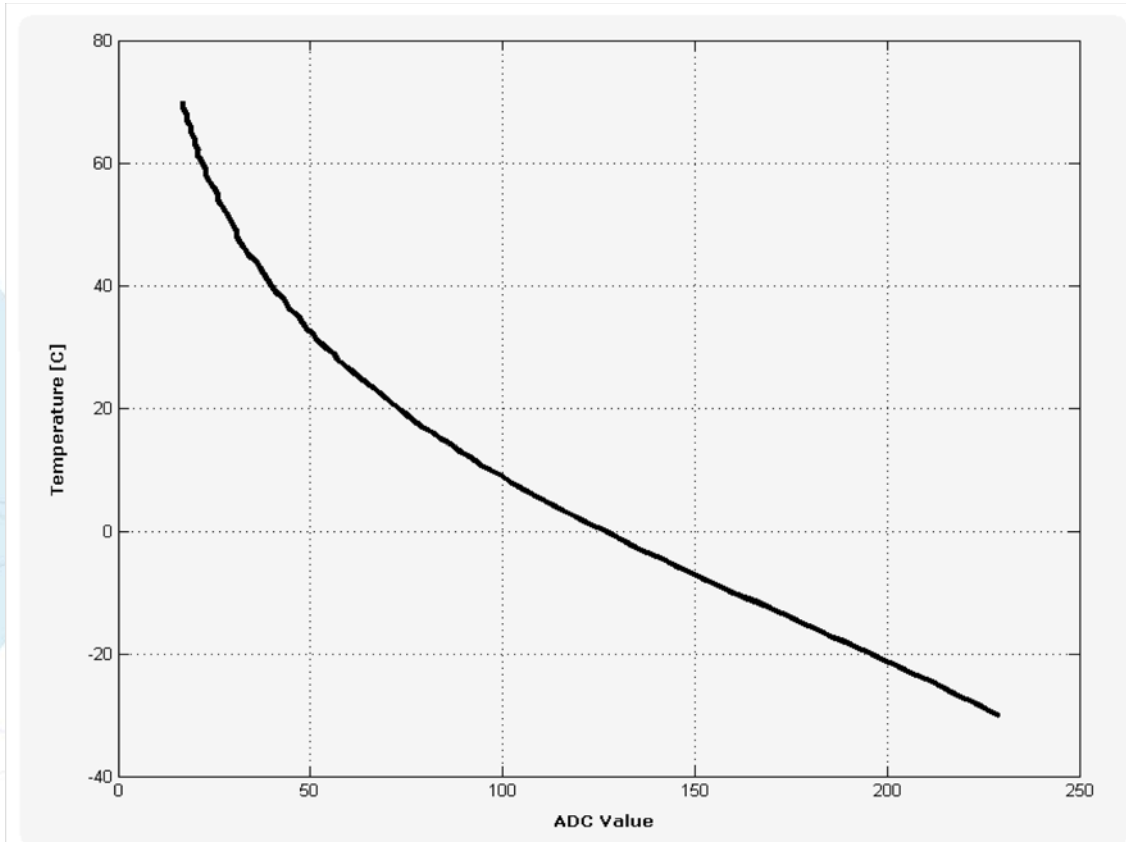

Figure 5-1: Actual Temperature Level (in degrees Celsius)

Antenna Presence

Antenna presence measurement reports whether antenna is attached or not.

MIDlet Watchdog

The watchdog is a guard that keeps the system alive, and will restart the G24 when a MIDlet lockup is detected.

Once it is activated platform initiates a timer. Timer expiry is considered a MIDlet lockup.

UM should kick the watchdog timer in order to reset it.

Once it is activated, the platform sends events every 10 seconds that can be caught by OSCWdogListener interface implementer. This will allow the MIDlet to kick the watchdog timer (by calling KickMIDletWatchdog) without maintaining its own Timer mechanism.

Note: The watchdog default state is not active.

WebSession Package

Package name: com.motorola.oem.websession

Web Session is a collection of parameters which configure and manage the Internet connection (GPRS, MMS).

There are 2 types of web sessions used by Java platform for network (GPRS) connection. It is the user responsibility to set these parameters which are operator's specific:

Java Session - used for all javax.microedition.io (MIDP2.0), with addition of OTADownload APIs.

Mms Session - used for MMS send/receive (including emails).

Prov Session - used for session parameters provisioned by a browser message

FOTA Session - used for over-the-air update of the G24-J firmware. This session must be initialized by the UM on power up.

OTADownload

The OTADownload class enables the UM to update itself over the air (JAD and JAR).

OTADownload is using "Java Session" parameters by default.

In order to enable the OTA download, UM should provide a URL to the requested MIDlet suite along with all OTA websession parameters. Once the download process started, "there is no return" and the running MIDlet will be closed.

MIDlet downloading and installing is fully automatic. In case of a successful download and install, the new MIDlet will start automatically. In case of a failure, previous MIDlet will be launched again (if it's the DM a report will be send to all saved report addresses).

OTADownload uses HTTP 1.1 and WAP 2.0 protocols.

WebSessionManager

The WebSessionManager class manages Web Sessions entries addition, deletion, update and setting the "current" G24 Web Session.

Session provisioning-

Web session's OTA Provisioning is the process, by which the carrier configures a web session.

The user may "listen" to a "browser settings received" event, indicating the arrival of a new "browser settings" (sent by the carrier). In case web session update is accepted by the MIDlet, the "**Prov Session**" web session entry is overridden with the newly received settings.

The "browser settings" message may contain an optional parameter which indicates the security mechanism used. If the parameter is not present, no security is used. If the parameter is present it must take one of the values: AUTH_METHOD_NETWPIN,

AUTH_METHOD_USERNETWPIN, AUTH_METHOD_USERPIN, and AUTH_METHOD_USERPINMAC.

The following table describes the 3 predefined (reserved) web session entries:

Web Session Name	Web Session Name	Web Session Index
Java Session	"Java Session"	SESSION_INDEX_JAVA
Mms Session	"Mms Session"	SESSION_INDEX_MMS
Prov Session	"Prov Session"	SESSION_INDEX_PROV

Note: Prov Session is read only.

See [Table 5-4](#) for Web Session Parameters.

Table 5-4: Web Session Parameters

Web Session Parameter	Sub Parameters	Parameter Description	Possible values	Default value
Access				
Name		Web session name	Any name, except for the reserved session names.	
Home Page		URL		
Gateway IP 1/2		Gateway IP		null
Port 1/2		Port number	8080 (HTTP) 9201 (WAP)	Port 1: 8080 Port 2: 9201
Domain 1/2				
Service Type 1/2		Service Type for the connection	wap, wap_connectionless wap_secure, wap_secure_connectionless http http_secure Note: For MIDP2 connections use http and http_secure only.	HTTP
DNS 1/2		DNS URL		
DNS 2		DNS URL		
Time Out		Connection timeout	In minutes: 1, 2, 5, 10, 15	15

Table 5-4: Web Session Parameters (Cont.)

Web Session Parameter	Sub Parameters	Parameter Description	Possible values	Default value
CSD 1/2	Phone Number User Name Password Speed Line type	CSD session 1 and 2 configuration	Speed Baud rates available: 2400, 4800, 9600, 14400 Line type available: Modem, Isdn	Speed: 14400 Line type: Modem
GPRS	APN User Name Password	GPRS session access parameters		null

HAPI Package

Package name: com.motorola.oem.hapi

The G24 KJAVA product supports two hardware-controlling APIs:

- GPIO API
- A2D API

GPIO API

The GPIO API is responsible for configuring and handling the I/O pins.

The API allows direct access to GPIO lines for:

- Read pin status
- Write to pin
- Interrupt or counter (enable/disable)

Several GPIO lines support two configuration modes:

1. **Interrupt** - Receive notifications on edge-triggered, according to pre-defined notification and debounce type.

Available GPIOs: 1, 14, 15, 16

2. **Counter** - Receive notifications on counter expiry according to pre-defined notification type, counter type and counter expiry value.

Available GPIOs: 14, 15

Working in counter mode enable system to receive interrupts in high frequency.

Notifications to user about counter expiry occurrence will arrive only when reaching pre-defined number of interrupts - counter expiry value. See [Figure 5-2](#) for GPIO counter mechanism.

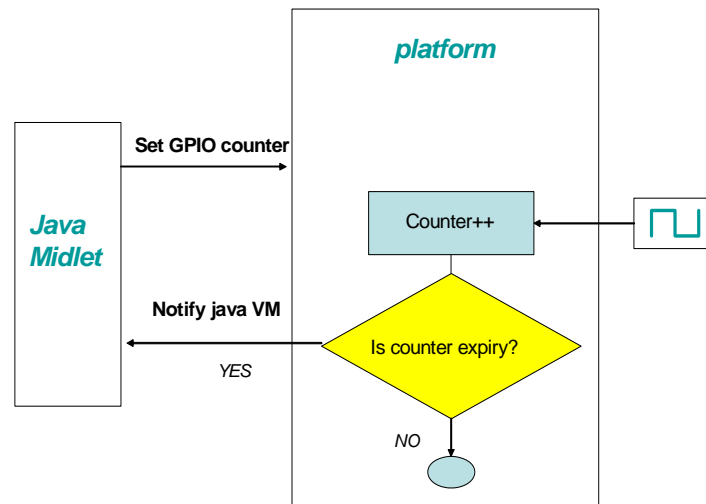

Figure 5-2: GPIO Counter Mechanism

Interrupt and Counter performance

1. Interrupt latency - notification to UM.
 - Idle - 10 ms.
 - While HTTP download session - 15 ms.
 - While UDP download session - 20ms.

Note: For both HTTP and UDP, thread yielding must occur. See “GPIO Interrupt Latency” for more information.

2. Counter frequency:
 - Idle - 2 KHz.
 - While HTTP download session - 500 Hz.

For additional GPIO information refer to “GPIO Lines”.

GPIO Classes

1. **GpioInput** - GPIO configuration as input, interrupt or counter.
Actions: read status, enable/disable interrupt/counter
2. **GpioOutput** - GPIO configuration as output.
Actions: write
3. **GpioInterruptConfig** - is container of interrupt GPIO.
Configuration: notification type, debounce type, and notifications listener.
Default configuration values:
 - a. Debounce: 40ms (Normal).
 - b. Notifications: both edges.

Note: Gpio interrupt performance are detailed in “GPIO Interrupt Latency”.

4. **GpioCounterConfig** - is container of counter GPIO.
Configuration: notification type, counter type, counter expiry, and notifications listener.
Default configuration values:
 - a. Debounce: disabled (Can not be changed).

- b. Notifications: both edges.
 - c. Counter: cyclical.
 - d. Counter expiry: 50 pulses.
5. **GpioCounter** - Service methods for GPIO counter.
Actions: Read and reset counter.

A2D API

A2D API is responsible for configuring and handling the 3 external A2D converters, pins: 37, 43 and 47.

Converter values are between 0 to 255 unit ranges, representing 0-2.3 Volt.

Automatic notifications:

1. Periodical - cyclically with pre-defined period.
2. Threshold - notification upon Voltage (see [Figure 5-3](#)):
 - a. Below the "low limit range".
 - b. Above the "high limit range".

A2D automatic notification default state is OFF.

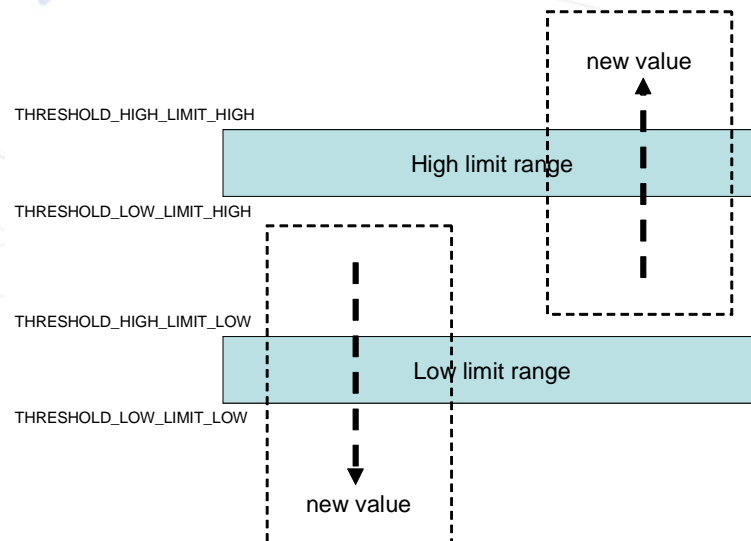

Figure 5-3: Threshold's Conditions for Auto Notification by Threshold Mode

G24 Performance

1. Periodical notification - Every 4 sec. at the minimum (defined by multiples of 4 sec).
2. Due to system architecture, threshold notification may be delayed up to 4 sec.

A2D Classes

1. **A2dManager** - Manages the access to A2D converters.
2. **A2dChannel** - A2D converter configuration and notification (access to A2D value, Enable/Disable notification).
3. **A2dAutoPeriodConfig** - A2D period notification container, default period is 4 sec.
4. **A2dAutoThresholdConfig** - A2D threshold notification container.
Default value for "low limit range" - 50 to 60 and "high limit range" - 190 to 200.

Call Package

Package name: com.motorola.oem.call

This package enables the UM to perform a single MO/MT voice or data call.

Contains: interface "DataCallConnection" and classes "Call" and "DataCallConfig".

The interface "DataCallConnection" is based on the Generic Connection Framework and extends the StreamConnection interface.

The major features of the package are:

- Dial, Answer or release a call.
- Indicates call direction, number and type.
- Report call state and call exit cause.
- Configure air link parameters for the next MO data call.
- Get Radio Link Protocol parameters range to be used in air link configuration.
- Several events type Voice/Data call alerts and state change events.

I2C Package

Package name: com.motorola.oem.i2c

I2C package provides standard GCF API to communicate with I2C driven peripherals.

I2C serial bus is available through two GPIO lines.

The following table defines mapping of I2C bus lines to GPIO lines in G24 70 pins connector.

BUS Identifier	SDA	SCL
BUS0 (default bus)	32	34
BUS1	32	34

I2C API utilities:

- Create connection
- Close connection
- Open new Datagram
- Connection configuration
- Provide data transfer mechanism to devices on the bus - read / write
- General call address

I2C default configuration:

After opening I2C connection, its default configuration will be:

Bus mode: Single master.

Data rate: Standard.

Device address type: 7 bits.

Register address length: 0 byte.

Start Type: start bit.

Receive start bit enabled: True.

Receive stop bit enabled: True.

I2C performance:

- Data rate -
 1. I2C support standard mode - up to 100 Kbit/s.
 2. G24 I2C bus effective data rate is 80 Kbit/sec.
 3. Due to I2C devices characteristic of fully data rate downwards compatible, G24 will be able to communicate with I2C devices that support higher data rate such as Fast mode (up to 400 Kbit/s), or High speed (up to 3.4 Mbit/s).
- Max datagram size is limited to 1024 Bytes (datagram will be fragmented to chunks of 128 bytes).

I2C HW adjustment:

In order to adjust bus lines rising time to I2C specification, 4.7 KOhm pull up resistors must be connect to bus lines.

I2C restrictions:

- I2C API support only single master mode. Any attempt to set another configuration will generate exception.
- I2C API support only 7 bits device address. Any attempt to set another configuration will generate exception.
- I2C API support 0, 1 or 2 bytes register address length. Any attempt to set another configuration will generate exception.
- I2C API support only standard data rate. Any attempt to set another configuration will generate exception.
- MIDlet will be able to open only single I2C Connection for each bus ID. Any attempt to open another connection of this bus will generate exception.
- I2C bus shares physical bus lines with GPIO API. On power up these lines are not dedicated to I2C-bus utilizing.
- In case the GPIO lines are already being used (GPIO API already holds them), I2C connection will not be opened and will generate exception.
- Until closing connection any attempt to configure these lines to work as GPIO lines will generate GpioException.
- Max datagram size is limited to 1024 Bytes. Upon attempt to exceed this limitation, request will be ignored and IOException will be generated.
- Max stretching time, allowed by attached device to the bus is 100 ms. If after 100 ms the attached device still holds the SCL line, the G24 will return one of the following :
 1. Device not response - in case it is the first byte transfer on the bus.

2. NACK - in case it is not the first byte transfer on the bus.
- For known issues, please refer to G24-J Customer Notes.

IPD Package

Note: For detailed information regarding IPD, see [“IP Director”](#).

Package name: com.motorola.oem.ipd

com.motorola.oem.ipd package enables the UM to utilize the IP Director feature, to establish local socket connection over the serial link with an external device.

A local socket is an IP based socket (over PPP), which bounds a server/client that resides in the MIDlet, to a client/server that resides in an external device connected to the serial port.

This package contains interface IpDirectorAvailabilityListener and class LocalSocketManager.

Interface IpDirectorAvailabilityListener is a listener for IP Director state change events.

This interface contains a single method onIpdStateChanged.

Class LocalSocketManager implements the local socket management.

Class methods allow access to connection parameters (IP addresses and port number), and use of the listener described above.

IPD Connection Services

When IPD is active (See [“IPD Activation”](#)), the MIDlet may connect to the external device using the external device's IP in the following Connection interfaces/methods:

1. **Standard MIDP interfaces:**

- SocketConnection,
- ServerSocketConnection,
- DatagramConnection,
- UDPDatagramConnection,
- HttpConnection,
- HttpsConnection,
- SecureConnection.

2. **OEM proprietary methods:**

com.motorola.oem.websession.OTADownload.startOTA().

That is, 'OTA' download of a new User MIDlet over a Serial link (UART/USB). See [“OTA \(Over The Air\) Over Serial PPP Link”](#).

Standard Classes Deviations

Comm Connections

Package: javax.microedition.io.CommConnection.

Description: Handling serial connection.

Three parallel serial ports are available: UART1, UART2 and USB.

See [Table 5-5](#) for Port to Serial mapping.

Table 5-5: Port to Serial Mapping

Port Identifier	Serial
COM0	UART2
COM1	UART1
COM2	UART2
COM3	USB

Server Socket Connection

Package: javax.microedition.io.ServerSocketConnection.

Description: Handling listen TCP/UDP socket.

Deviations:

1. One client per connection socket (up to 9 sockets).
2. More than one ServerSocketConnection instance may listen on the same port.

Example for handling server socket connection:

```
public class TcpConnection extends Thread {
    public SocketConnection sc = null;
    public ServerSocketConnection scn = null;
    public InputStream is = null;

    public void run() {
        //gets port number from jad file
        openConnection(getAppProperty("PORT"));
        byte[] ReceiveData = new byte[256];
        try {
            InputStream is = sc.openInputStream();
```

```

        while (true) {
            int len = is.read(ReceiveData);
            if (len > -1) {
                //receive data
                System.out.println("Receive data - " + new
String(ReceiveData) + "\n");

                System.out.println("Number of bytes - " + len +
"\n");

            } else if (len == -1) {
                //connection with client has been broken.
                openConnection(getAppProperty("PORT"));
            }
        }
    } catch (IOException e) {
        ...
    }
}
private void openConnection(String port) {
    try {
        //create ServerSocketConnection instance
        scn = (ServerSocketConnection) Connector.open("socket://" + port);
        //wait for client connection.
        sc = (SocketConnection) scn.acceptAndOpen();
        sc.setSocketOption(SocketConnection.LINGER, 5);
    } catch (IOException e) {
        //cannot open connection
        ...
    }
}
}
}

```

Note: In order to open more sockets in parallel, use another TcpConnection thread.

Message Connection

Package: javax.wireless.messaging.

Default SMS Port API.

All regular incoming SMS (without destination and source port) will be redirected to a special, default MT port;

- Destination port - 6024
- Source port - 49153

In order to be able to get this kind of SMS, MIDlet should listen on port 6024 using JSR120.

MIDlet Messages are stored in a separate JSR120 Inbox folder (up to 26 messages).

When this folder reaches its limit then the oldest unread message in a group of existing port (xxxx) will be deleted. If no group port messages exist the oldest unread message in the folder will be deleted.

Notification about Incoming Message

There are two main use-cases for message arrival:

1. MIDlet is running
MIDlet handles message (registered to 6024 port).
2. MIDlet is not running
SMS will be stored in the JSR120 Inbox folder. When MIDlet is launched and registers to 6024 port, then incoming SMS will be handled it and deleted from storage.

File Connection

Package name: javax.microedition.io.file

G24-J team recommends saving files and creating directories in root '/c/'.

For example:

```
fileConnection = (FileConnection) Connector.open("file:///c/<my_file>");
```

Location API

Package name: javax.microedition.location

G24-J Location mechanism is the result of JSR179 implementation.

The Location APIs feature allows obtaining updated location information (longitude, latitude, altitude, speed, course etc.) from a GPS device by Request or Periodical Listening.

Connection of a GPS Device to G24-J

GPS receiver may be connected to the G24-J via serial port UART1 or UART2. TX and RX lines are required for this connection. Optionally, flow control lines CTS and RTS can be connected.

Initialization of a GPS Device

The GPS device should be initialized before usage, in order to wake-up in the periodical broadcasting NMEA mode. The special commands in binary format could be sent using Comm Connection APIs. It could be @@Oi, @@OF, @@Oa, @@Oj, @@Ot, @@Oa configuration commands for basic GPS initialization and \$PMOTG commands to assign NMEA format for broadcasted messages. These commands may be different for different GPS types.

Usage example in Java MIDlet:

```
// Open connection with UART2 in order to initialize GPS
CommConnection commConnectionUart2
=(CommConnection)Connector.open("comm:COM2;baudrate=19200;autocts=off;autorts=off",
Connector.READ_WRITE, true);
oStreamUart2 = commConnectionUart2.openOutputStream();
System.out.println("Start GPS initialization...");

// Initilize GPS
oStreamUart2.write(CommandArray); // When CommandArray is a Byte array of a GPS specific
initialization command.
oStreamUart2.flush();

// Close connection
oStreamUart2.close();
commConnectionUart2.close();

System.out.println("End GPS initialization.");
```

Setting of Selected G24-J UART Communication Properties for Location Session

UART communication properties could be changed by special OSC property *oem.uart.config*.

Usage:

```
OSC.setProperty("oem.uart.config", settings string);
```

Setting string format:

```
"comm:<uart_id>;[baudrate:<baudrate_value>];[databits:<databits_value>];
[stopbits:<stopbits_value>];[parity:<parity_value>];[fc:<fc_value>]"
```

Parameters in square brackets are optional. If an optional parameter is omitted, the default value will be set. The following table shows the possible parameters values:

Parameter	Description	Port setting	Possible values	Default Value
<i>Comm..</i>	UART number.	<uart_id>	"com1", "com2"	N/A
<i>baudrate</i>	UART speed.	<baudrate_value>	"110", "150", "300", "600", "1200", "2400", "4800", "9600", "14400", "19200", "28800", "38400", "57600", "115200", "230500", "460800", "921600"	19200
<i>databits</i>	Number of data bits per character.	<databits_value>	"7", "8"	8
<i>stopbits</i>	Number of stop bits per character.	<stopbits_value>	"1", "2"	1
<i>parity</i>	Parity.	<parity>	"odd", "even", "none"	None
<i>Fc</i>	Flow control.	<fc>	"hw", "sw", "none"	None

Usage examples in Java MIDlet:

```
OSC.setProperty("oem.uart.config", "comm:com2;databits:8;stopbits:2;parity:odd;");
OSC.setProperty("oem.uart.config", "comm:com1;baudrate:4800;fc:hw;")
OSC.setProperty("oem.uart.config", "comm:com1;")
```

Location Session

After previous steps, the user can open the Location session in order to obtain relevant location information.

Request Location example in Java MIDlet:

```
QualifiedCoordinates coordinates = null;

// Set criteria for selecting a location provider:
// accurate to 500 meters horizontally
criteria = new Criteria();

criteria.setHorizontalAccuracy(500);

// open selected by OSC serial port(UART1 or UART2)
provider = LocationProvider.getInstance(criteria);

provider.getLocation(timeout);
```

```
// display location results
coordinates = location.getQualifiedCoordinates();
float altitude = coordinates.getAltitude();
double latitude = coordinates.getLatitude();
double longitude = coordinates.getLongitude();
```

Example of Periodical Listening for Location Update in Java MIDlet:

```
// Set criteria for selecting a location provider:
// accurate to 500 meters horizontally
Criteria criteria = null;

criteria = new Criteria();

criteria.setHorizontalAccuracy(500);

// open selected by OSC serial port (UART1 or UART2)
provider = LocationProvider.getInstance(criteria);

// Define Location listener with 4 seconds Location data update
provider.setLocationListener(this, 4, -1, -1);
...
// Listener method
public void locationUpdated(LocationProvider provider, Location location)
{
    QualifiedCoordinates coordinates = null;

// display location results
coordinates = location.getQualifiedCoordinates();
float altitude = coordinates.getAltitude();
double latitude = coordinates.getLatitude();
double longitude = coordinates.getLongitude();
}
```

Note: Orientation and ProximityListener classes of JSR179 are not implemented in G24 Location API.

Appendix A: GPIO Lines

Pin assignment details for G24 KJAVA module GPIO lines are listed in the following tables.

- Note:**
- GPIO 1-8 can be accessed via EVB switch S120.
 - Pin dedicated for **Java Tool** is marked yellow.
 - GPIO13 must **not** be grounded at power up.
 - If GPIO direction is input and line is not connected, its state will be defined according Initial value.
 - If GPIO direction is output, "Floating" state is not available. Initial state depends on initial configuration. This configuration can be controlled by Java GPIO API.
- Y=Yes; N=No.
I = Input; O = Output; I/O = Input/Output.

Table A-1: Java Module GPIO Lines, OEM Units

70 Pin Conn. Pin No.	G24 Signal	Java Signal	Internal resistor (Pull Up)	Initial Value	Direction	Default Direction	Input	
							Interrupt	Counter
28	GPIO1	GPIO1	100k	1	I/O	I	Y	N
30	GPIO2	GPIO2	100k	1	I/O	I	N	N
32	GPIO3	GPIO3	22k	1	I/O	I	N	N
34	GPIO4	GPIO4	22k	1	I/O	I	N	N
36	GPIO5	GPIO5	22k	1	I/O	I	N	N
38	GPIO6	GPIO6	22k	1	I/O	I	N	N
40	GPIO7	GPIO7	22k	1	I/O	I	N	N
42	GPIO8	GPIO8	22k	1	I/O	I	N	N
41	ANT_DET	GPIO9		0	O	O	N	N
49	GPRS	GPIO10		0	O	O	N	N
26	WKUPO_N	GPIO11	22k	1	O	O	N	N
23	RI_N	GPIO12	100k	1	I/O	I	N	N
13	DSR_N	GPIO13	100k	1	I/O	I	N	N

Table A-1: Java Module GPIO Lines, OEM Units (Cont.)

70 Pin Conn. Pin No.	G24 Signal	Java Signal	Internal resistor (Pull Up)	Initial Value	Direction	Default Direction	Input	
							Interrupt	Counter
19	DTR_N	GPIO14	100k	1	I/O	I	Y	Y
17	DCD_N	GPIO15	100k	1	I/O	O	Y	Y
16	WKUPL_N (EVBS100)	GPIO16	22k	1	I/O	I	Y	N

Table A-2: Java Module GPIO Lines, HMI Units

70 Pin Conn. Pin No.	G24 Signal	Java Signal	Internal resistor (Pull Up)	Initial Value	Direction	Default Direction	Input	
							Interrupt	Counter
26	WKUPO_N	GPIO11	22k	1	O	O	N	N
23	RI_N	GPIO12	100k	1	I/O	I	N	N
13	DSR_N	GPIO13	100k	1	I/O	I	N	N
19	DTR_N	GPIO14	100k	1	I/O	I	N	N
17	DCD_N	GPIO15	100k	1	I/O	O	N	N
16	WKUPL_N (EVBS100)	GPIO16	22k	1	I/O	I	N	N

Appendix B: Default MIDlet Features

Supply Of All Available Unit Information

DM outputs all available unit information to the standard output. If it's an HMI unit, information is printed to the screen as well. Output information includes:

- DM Version
- Earliest required software version for present DM
- Software version
- Flex version
- Product description
- OEM mode
- IMEI
- MSISDN
- Unit Time and Date
- UM version
- Fault report address
- Last OTA status
- OTA fault data
- MIDlet run fault data
- DM SMS listener status

Fault Report

DM manages the fault report mechanism. There are two types of faults:

- Run fault - In case there was a critical error in UM or DM run-time (uncaught exception, VM error, etc.).
- OTA fault - In case an OTA download process has failed.

When DM loads, a fault report is sent automatically (in case fault information is available). In addition, the DM can be triggered to send a fault report using an SMS request.

The following table shows report types:

Report Type	Report Address	Report Address Example	Description
File	file	file	A text file containing a detailed report in XML format is saved in the file system under "file:///c:/mobile/kjava/" folder. Three fault reports may be saved, named "fault_report<n>.xml", where "fault_report1.xml" is the most recent and "fault_report3.xml" is the least recent. Only one fault report may be saved every session to prevent the same report from being written twice.
SMS	sms://<phone number>	sms://972541234567	An SMS message is sent to the phone number, containing the IMEI of the unit, and what fault information is available.
E-Mail	email://<email address>	email:// name@company.com	An E-Mail message is sent to the address, containing a detailed report in XML format.
HTTP/HTTPS	http://<web server address> https://<web server address>	http://www.example.com	An HTTP post request is sent to the address, in which the post variable "fault_report" contains a detailed report in XML format.

Note: All report addresses can be configured through SMS to DM and through OSC API.

CQA Testing Routines Handler

DM handles the CQA tests as part of the manufacturing process. DM implements several capabilities such as MT voice call and serial port communication, which are tested in the factory.

Note: This feature is enabled only in case there is no UM installed on the unit.

OTA Provisioning

DM handles OTA provisioning through WAP push messages (browser messages).

GPRS Indicator

DM "outputs" GPRS registration status to GPIO 11 - LOW represents registered, HIGH represents unregistered.

Note: This feature is enabled only in case there is no UM installed on the unit.

SMS Updates / Requests Listener

The DM starts an SMS listener which allows updates and requests to be sent to the unit. The SMS sent to this listener must meet a specific format.

Upon initialization, the DM reads the OSC property "oem.dm.smslistener", if set to "on", which is the default value, it starts listening to SMS messages. To turn off the listener set the property to "off". Using these messages, updates and requests can be sent to the unit.

Message Format

The SMS has to be sent to port 16001. The message is constructed from fields and values. The field and value are separated by a colon, and the fields are separated by an LF (line feed, "\n") sign or a CR (carriage return, "\r") sign. LF and CR are treated as the same character.

Example:

```
action:value  
field1:value  
field2:value  
field3:value
```

Additional notes:

- Every message must contain an "action" field which defines the update or request type.
- The order of the fields has no importance.
- If there is more than one occurrence of a field, the last occurrence will be used.
- The field strings and value strings are not case-sensitive.
- All field strings and value strings are trimmed.

Messages Types

Supported messages:

- Java/Mms Session Update
- OTA Download Triggering
- Fault Report Addresses Update
- Fault Report Triggering
- Ping

Java/MMS Session Update

This message updates the "Java Session" or "Mms Session" web sessions.

Additional notes:

- The only difference between the two is the action field.
- If the message contains a field with an invalid value, the message is dismissed.
- To set a field to its default value, don't include the field in the message.
- The update replaces the full Web Session, not specific fields. Old values are not saved.

Message fields are given in the table below:

Description	Field String	Valid Values	Notes
Action to be performed (Update "Java Session" or "Mms Session" web sessions)	action	<ul style="list-style-type: none"> java session mms session 	This field defines the message type. This is a mandatory field.
Homepage	homepage		This field is used as a default OTA download URL.
Service Type 1	service1	<ul style="list-style-type: none"> wap wap connectionless wap secure wap secure connectionless http http secure 	Default value is http
Proxy 1	proxy1		
Port 1	port1		Default value is 8080
Domain 1	domain1		
Service Type 2	Service2	<ul style="list-style-type: none"> wap wap connectionless wap secure wap secure connectionless http http secure 	
Proxy 2	proxy2		
Port 2	port2		Default value is 9201
Domain 2	domain2		
DNS 1	dns1		
DNS 2	dns2		
Timeout (minutes)	timeout	<ul style="list-style-type: none"> 1 2 5 10 15 	Default value is 15
CSD No. 1	csd1		
CSD No. 1 User Name	csduser1		
CSD No. 1 Password	csdpass1		
Speed (Bps) 1	speed1	<ul style="list-style-type: none"> 2400 4800 9600 14400 	Default value is 14400
Line Type 1	line1	<ul style="list-style-type: none"> modem isdn 	Default value is modem

Description	Field String	Valid Values	Notes
CSD No. 2	csd2		
CSD No. 2 User Name	csduser2		
CSD No. 2 Password	csdpass2		
Speed (Bps) 2	speed2	<ul style="list-style-type: none"> • 2400 • 4800 • 9600 • 14400 	
Line Type 2	line2	<ul style="list-style-type: none"> • modem • isdn 	Default value is modem
GPRS APN	apn		
GPRS User Name	gprsuser		
GPRS Password	gprspass		

Example: Update the Java Session

```

action:java session
homepage:http://www.domain.com/directory/midlet.jad
service1:wap
service2:wap
csd1:+972540000000
port1:9201
port2:9201
apn:internet

```

OTA (Over the Air) Download Trigger

This message triggers an OTA download of a new MIDlet to the unit. If the message does not specify a JAD file URL, the homepage parameter of the "Java Session" web session will be used as a URL.

Message fields are given in the table below:

Description	Field String	Valid Values	Notes
Action to be performed: OTA download trigger	action	ota	This field defines the message type. This is a mandatory field.
JAD File URL	url		

Example 1: Download, install and run the MIDlet found at the homepage of the "Java Session" web session

```
action:ota
```

Example 2: Download, install and run the MIDlet found at
<http://www.domain.com/directory/midlet.jad>

action:ota

url:<http://www.domain.com/directory/midlet.jad>

Fault Report Addresses Update

This message updates the fault report addresses of the unit.
 Message fields are given in the table below:

Description	Field String	Valid Values	Notes
Action to be performed: Update fault report address	action	report address	This field defines the message type. This is a mandatory field.
Report Address 1	address1		Must be a valid address
Report Address 2	address2		Must be a valid address
Report Address 3	address3		Must be a valid address

Example 1: Update fault report address 1 to email://name@company.com.

action:report address

address1:email://name@company.com

Example 2: Update fault report address 1 to email://name@company.com, fault report address 2 to email://anothername@anothercompany.com and don't use fault report address 3

action:report address

address1:email://name@company.com

address2:email://anothername@anothercompany.com

address3:

Request for Fault Report

This message commands the unit to report the fault information to its defined addresses. The report happens automatically when the DM loads if there is fault information available.
 Message fields are given in the table below:

Description	Field String	Valid Values	Notes
Action to be performed: Report fault information	action	fault report	This field defines the message type. This is a mandatory field.

Example: Report the fault information to the defined addresses.

action:fault report

Ping

This message is used to verify if the unit is working. When the DM receives this message, it returns a message to the sender containing the text "Ping (Motorola Wireless Modules)". Message fields are given in the table below:

Description	Field String	Valid Values	Notes
Action to be performed: Ping the unit	action	fping	This field defines the message type. This is a mandatory field.

Example: Ping the unit.

action:ping

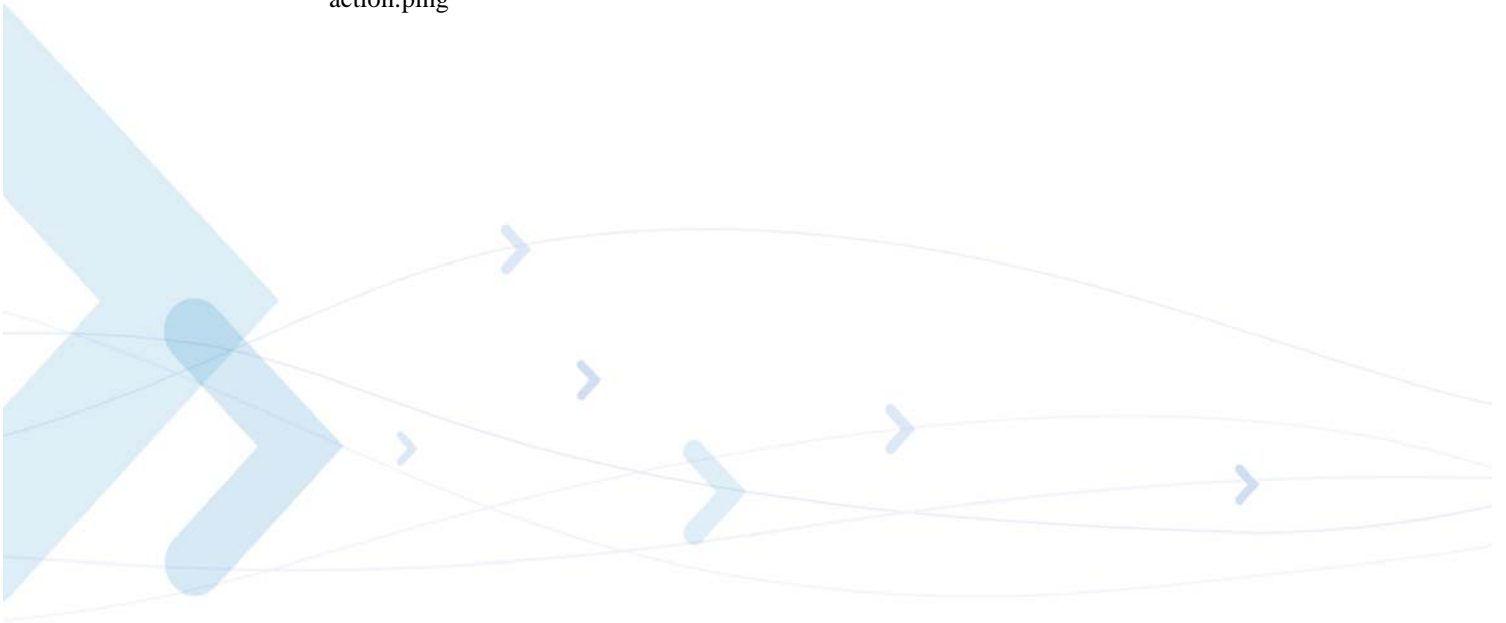

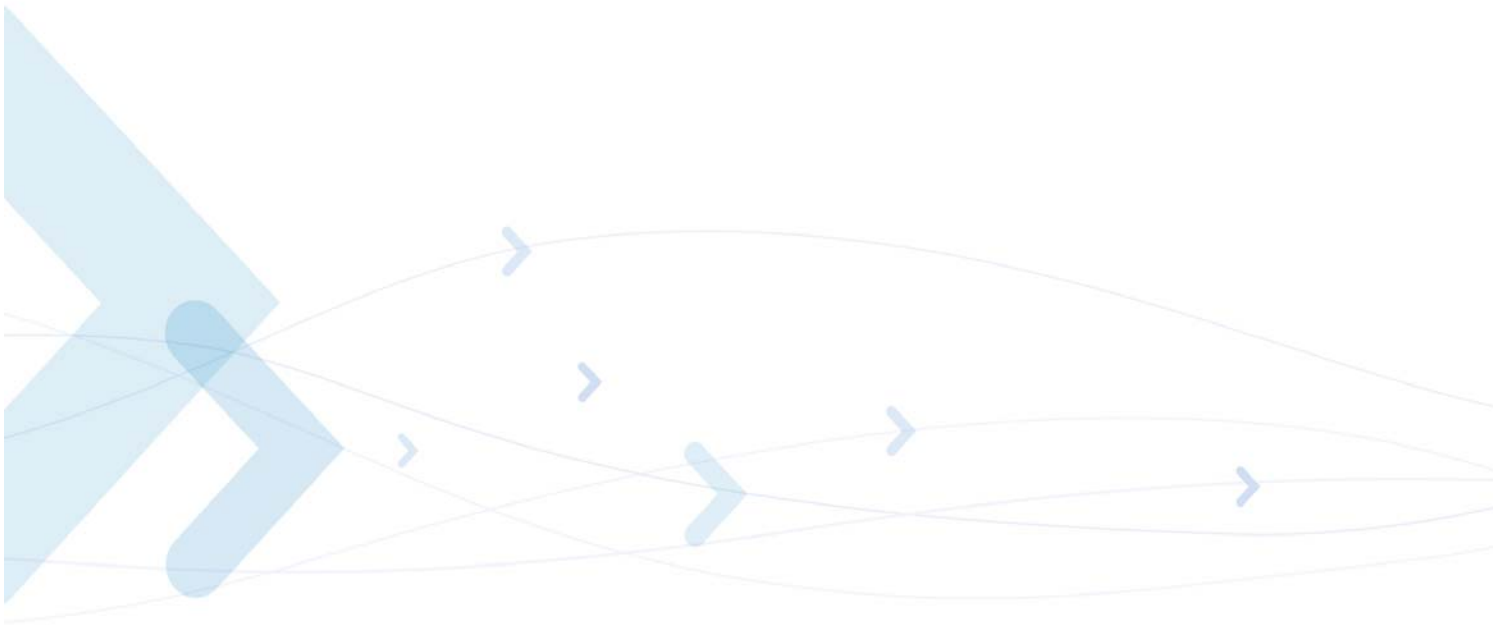

Appendix C: GPIO Interrupt Latency

Introduction

In order to achieve minimal average interrupt latency (HW I/O to Java) one should understand JVM limitation, and how to manipulate code accordingly.

Java VM provides limited RT abilities. Programming in a multithreading environment while trying to ensure strict RT scheduling, is an impossible mission. As a result, working in such an environment will cause interrupt latency to be inconsistent, specially when parallel threads consume large amount of VM resource (i.e. +UDP or HTTP connection).

Multithreading Background

A basic understanding of how to use threads is the key to writing effective J2ME applications. Some important issues about multithreaded environments are listed below:

1. Scheduling
Thread scheduling is a complicated affair over which the application has little control. The KVM scheduler allocates byte code slot for current running thread (classical OS uses run time slot). It impossible to ensure fix run time for a fixed number of bytes code slot.
2. Priority
The only real influence the application has over thread scheduling is via the thread's priority level: higher-priority threads execute more often than those with lower priority (default thread priority is NORAML PRIORITY).

A thread keeps running until:
 - It yields by calling the yield method
 - The scheduler selects new thread to run
3. Garbage collection
Has higher priority then any other user thread, therefore will always have precedence over user thread.
This behavior may cause inconsistent interrupt performance.

How To Achive Minimal Latency

Limited control over JVM scheduling mechanism can be achieved using Thread class:

- Thread.setPriority(priority level) -
This method enables user to adjust, in runtime, the current thread priority (range is from MIN_PRIORITY to MAX_PRIORITY).

- `Thread.yield()` -
This method enforces current thread to give up the CPU resource.

In order to create minimal average interrupt latency, one should set interrupt thread (`NativeExtEventThread`) priority to the maximum level, other threads to the lower one and limit those threads execution time by using `yield` function (if not used, interrupt thread can be delayed for a significant amount of time: 40-50 milliseconds).

Code Example

The following code example demonstrates the use of the above sections:

```
public class myMidlet extends MIDlet implements GpioInterruptListener{

    void startApp(){
        // Define gpio 15 as input and enable interrupts on it.
        GpioInput gpioInput = new GpioInput(15);
        GpioInterruptConfig gpioInterruptConfig = new GpioInterruptConfig(this);
        gpioInterruptConfig.enableDebounce(false);
        gpioInterruptConfig.setNotificationType(GpioInterruptCon-
        fig.NOTIFICATION_TYPE_LOW_TO_HIGH);
        gpioInput.enableInterrupt(gpioInterruptConfig);

        // Start the HTTPConnection thread.
        HTTPConnection myHttp = new HTTPConnection("http://www.domain.com");
        myHttp.start();
    }
    ...

    public void onInterrupt(int gpioNum, boolean val) {
        // Set onInterrupt thread priority to MAX priority.
        Thread.currentThread().setPriority(Thread.MAX_PRIORITY);
    }

    // HTTPConnection is used to demonstrate VM resource consuming thread.
    protected class HTTPConnection extends Thread{
        private String url ;
        private HttpConnection conn;
        private InputStream iStream;

        public HTTPConnection(String Url){
            // Set HTTP connection thread priority to MIN priority.
            this.setPriority(this.MIN_PRIORITY);
            this.url = Url;
        }
        public void run(){
            conn = (HttpConnection)Connector.open(url,Connector.READ, true);
            iStream = conn.openInputStream();
            while(true){
                iStream.read();
                // HTTPConnection thread yield the CPU after each reading.
                this.yield();
            }
        }
    }
}
```

Appendix D: MIDlet Signing

General

There are two types of MIDlet signing:

- Generic signing
- Bound signing

Generic Signing

Generically signed MIDlet can be downloaded to all G24 units. Once a MIDlet is tested and ready for deployment to production, it will be generically signed.

Only the manufacturer (Motorola Wireless Modules) can generically sign a MIDlet.

To request a generic signature, refer to M2MCare@motorola.com.

Bound Signing

Bound signed MIDlet can be downloaded to a specific G24 unit. In development phase, in order to download a trusted MIDlet to a G24 unit, it should be "bound signed".

All the tools and documentation for establishing "bound signing" procedure are located in the "BoundSignBundle.zip" file, located at <http://developer.motorola.com/products/embeddeddevices/g24>.

The document "Signing a MIDlet with a BOUND Certificate (External Release)" details all the necessary steps to receive a "bound certificate".

The above procedure allows signing a MIDlet using a special certificate, called "bound certificate". Such a certificate is tied to the UID of the G24 unit.

Below is a summary of all the steps necessary for the developer to follow, in order to establish a "bound signing" procedure:

1. Download the "BoundSignBundle.zip" file.
2. Set up the digital signing environment by performing steps 2.2.1, 2.2.2, 2.2.3 and 2.2.4 from the "Signing a MIDlet with a BOUND Certificate (External Release)" document.
3. Create a Certificate Signing Request and collect UIDs by performing steps 10, 11, 12 from chapter 2.2.5 of the above document.
4. Fill in all the "G24_Bound_Cert_Request_Form_182-1.doc" with all the UIDs collected in the previous step (maximum 10 UIDs per request).

5. Send the "example.csr" file created in step 2 and the "G24_Bound_Cert_Request_Form_182-1.doc" created in step 4 to M2MCare@motorola.com. You will receive from Motorola a bound certificate within a few days.
6. Upon receiving the "Bound Certificate" (.crt) file from Motorola, you should create a directory for G24 in the following location: C:\BOUND_Certificate\cert\G24.

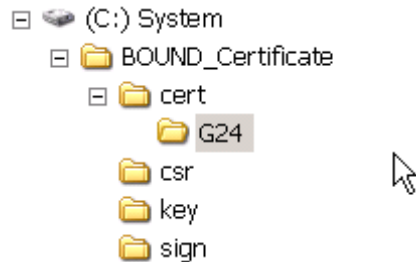

7. Place the "Bound Certificate" (.crt) file at the following location:
C:\BOUND_Certificate\cert\G24
It is important to preserve the above path since an automatic tool relies on it.
8. Open a command window and run the "BoundSign.bat" batch file as follows:
BoundSign.bat UserMIDlet 182-1.X

Where:

- "UserMIDlet" is the name of your midlet (without the jad or jar suffix).
- "182-1.X" is the certificate file name you received from Motorola without the crt suffix.

The "BoundSign.bat" batch file performs all the steps listed in chapter 2.2.6 of "Signing a MIDlet with a BOUND Certificate (External Release)" document.

Appendix E: IP Director

Using The IPD Feature

The external device will trigger the IPD state changes via a serial connectivity. There are two applicable java modes for the IPD:

1. Partial java mode 2.
2. Partial java mode 3.

See `OSC.setProperty("oem.mode", <mode-string>)`.

IPD Configuration

Configurable parameters are:

1. UM fixed IP - the MIDlet will be assigned a fixed IP by the IPD.
2. UM fixed Port - the MIDlet will be able to listen on a fixed Port Id which is recognized by the IPD (for server mode only).
3. External device fixed IP - the external device will be assigned a fixed IP by the IPD

The default configuration is:

1. UM fixed IP - 192.168.1.1.
2. UM fixed Port - 5001.
3. External device fixed IP - 192.168.1.2.

Reconfiguring of the IP addresses and port number can be done by using AT+MIAU command (see G24 AT Commands Reference Manual).

IPD Activation

The External device will generally have to establish a PPP link over serial, in order to activate the IPD. This can be done in one of two ways:

1. With GPRS

Issue *ATD*99#* command and establish PPP link (GPRS dialup). In this case the cellular network will assign an IP address (IP4 in the figure below) to the external device. External device may communicate with outside world Internet and the UM using the same PPP link.

Note: Although IP4 is different from IP2, the IPD handles MIDlet IP packets destined to IP2 and redirects them to IP4.

2. Without GPRS

Issue *AT+MDLC* command and establish PPP link. In this case the IPD will assign the fixed (AT+MIAU configured) preset IP (IP2 in the figure below), to the External device. The external device may communicate with UM sockets, but not with the Internet.

Note: For testing purposes only, *ATD*98#* command will establish the same PPP link with Windows dialer.

In both cases, the MIDlet is notified of the IPD new state by the IpDirectorAvailabilityListener. While IPD is active, the External device may access any open MIDlet socket by using the UM fixed IP (IP1 in Figure E-1 below) as DA.

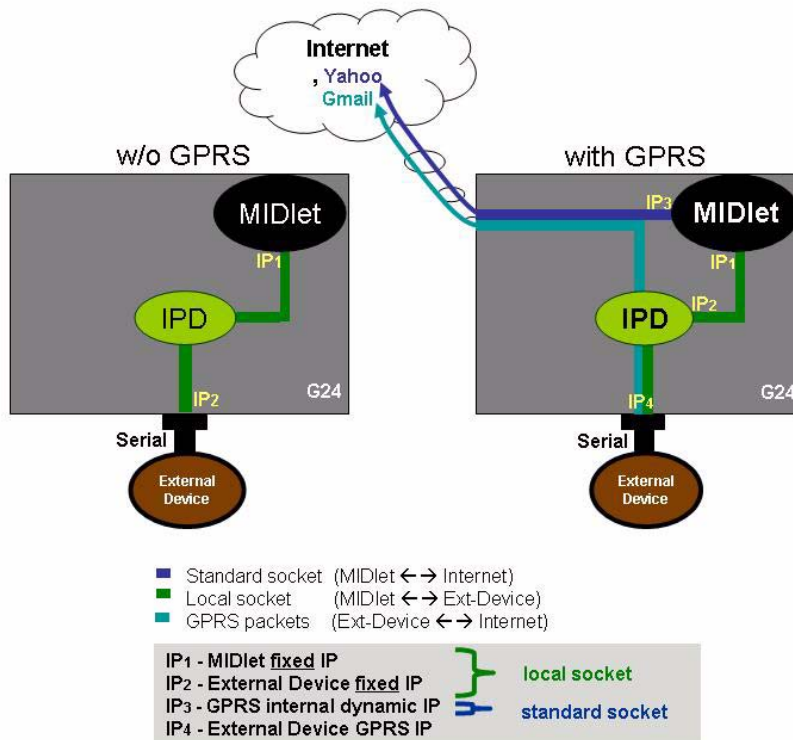

Figure E-1: IPD Active

IPD Deactivation

One of the following actions will deactivate the IPD:

1. External device terminated PPP by sending LCP-Terminate message.
2. External device dropped DTR line.

This will drop the PPP link in both cases (with and w/o GPRS) and will restore serial to AT command mode. The MIDlet is notified of the IPD new state by the *IpDirectorAvailabilityListener*. From this point on, the External device <--> MIDlet IP connection (local socket service) is unavailable.

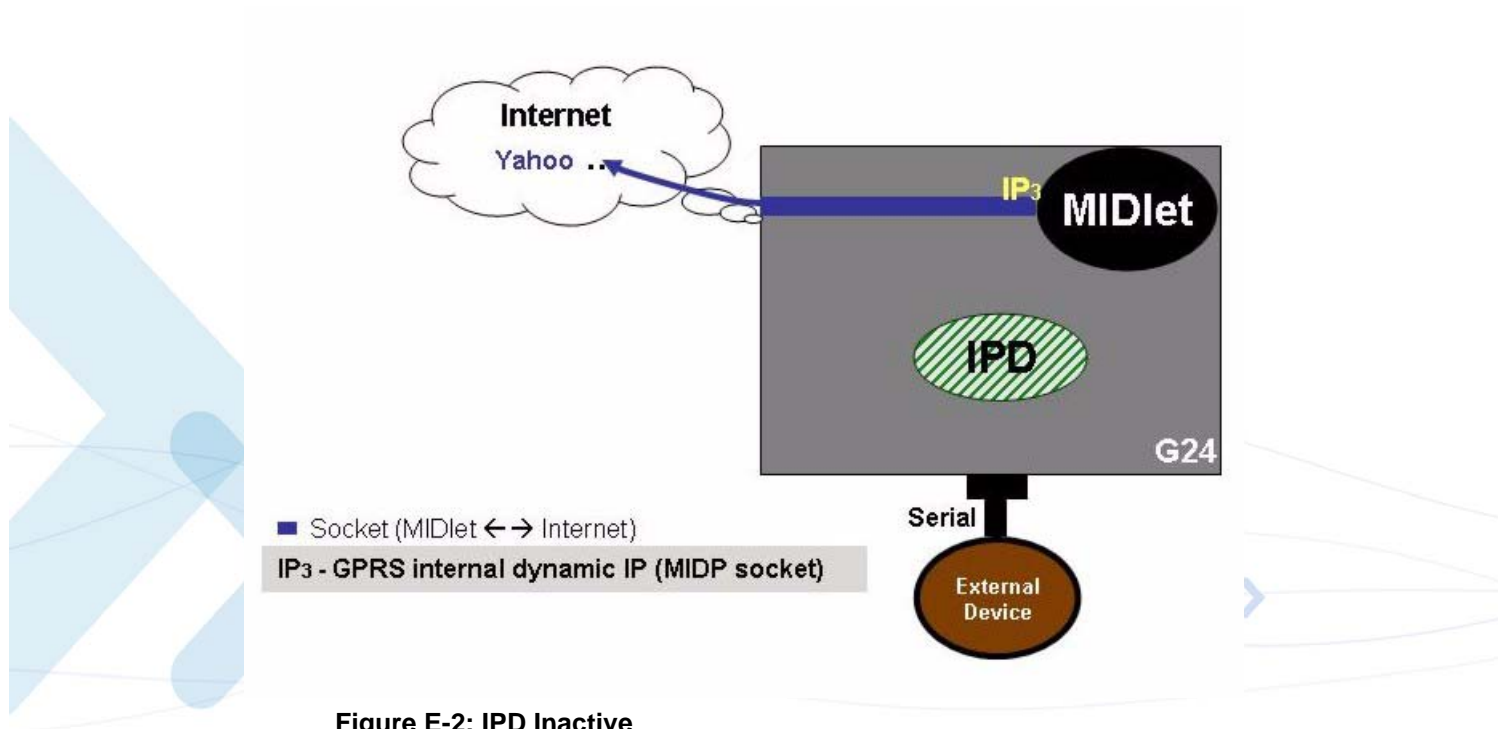
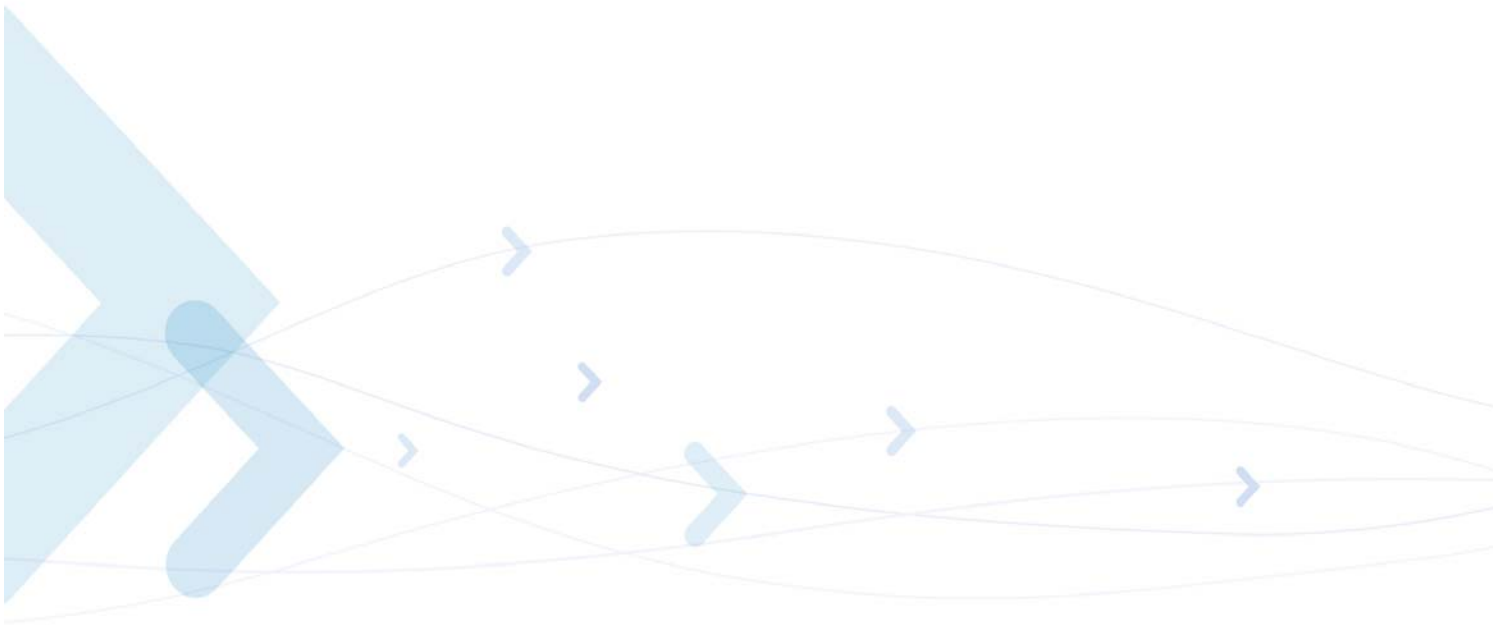

Figure E-2: IPD Inactive

OTA (Over The Air) Over Serial PPP Link

Generally, OTA process is done using WAP2.0 or HTTP1.1 protocols. HTTP is the recommended one. The external device processor should comply with MIDP2.0 specification section 2.1.10 in order to succeed with the OTA download.

Note: Please be aware that `startOTA(String MIDletURL)` method usually uses the Java Session as Web Session settings. The only Web Session obligation here is that proxy server's parameters 'proxy1' and 'proxy2' should remain empty during OTA over Serial process. The recommendation is to create one dedicated Web Session record for OTA over Serial without proxy settings and with a dummy APN value in it. Then use `index = addWebSession(newWS)` right before `startOTA(index)` call.





MOTOROLA and the Stylized M Logo are registered in the US Patent & Trademark Office.
All other product or service names are the property of their respective owners.
© Copyright 2007 Motorola, Inc.
Java? Technology and/or J2ME? : Java and all other Java-based marks are trademarks or registered trademarks of Sun Microsystems, Inc. in the U.S. and other countries.
UNIX? : UNIX is a registered trademark of The Open Group in the United States and other countries.



6802981C50-D