

ORG447X Series UART Demo Board

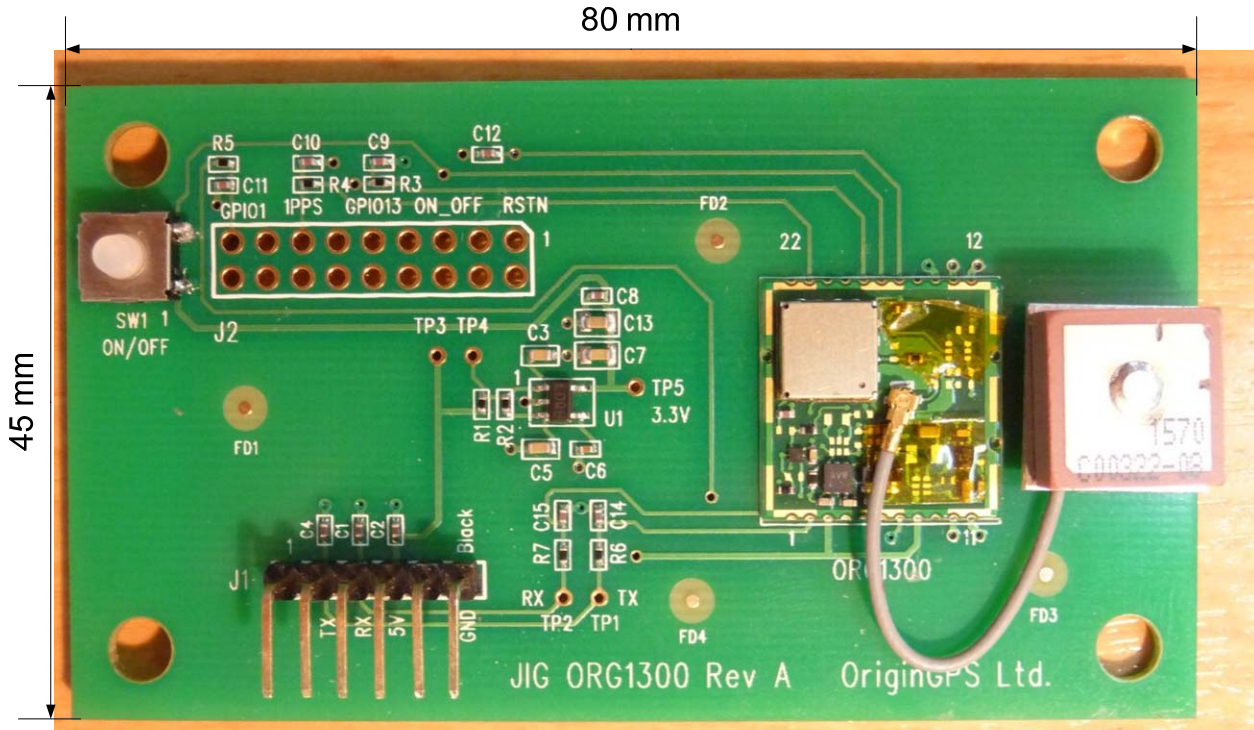

TTL-232R-3V3 USB – TTL Level Serial Converter



Description

Evaluation Kit of the ORG447X Series GPS Module comprises the Demo Board, USB to UART cable and CD with GPS simulator software and documentation.

The Demo Board is built of Main Board, incorporating 3.3V LDO regulator, UART connector, push-button tactile switch for Push-To-Fix™ interrupt and various test points.

The Demo Kit is equipped with miniature passive antenna assembly, connected to an ORG447X Interface Adaptor.

An ORG447X Interface Adaptor is soldered onto the Main Board.

An Interface Adaptor includes miniature RF input connector, 1.8V regulator, single buffer for voltage level translation of TX line, and voltage supervisor for autonomous power on, among several assembly options:

Assembly Option	Description	Notes
Option 1	1.8V Supply by LDO Regulator	Default
Option 2	1.8V Supply by Switch Mode Regulator	
Option 3	ON Pulse Delay by Integrated Supervisor	Default
Option 4	ON Pulse Delay by Logic Gates	
Option 5	Active Antenna Bias Control Circuit	

Options 1 and 3 are populated by default.

Customers are encouraged to apply different assembly option.

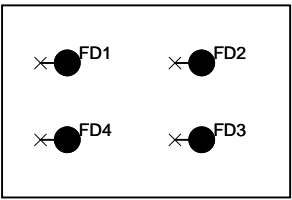
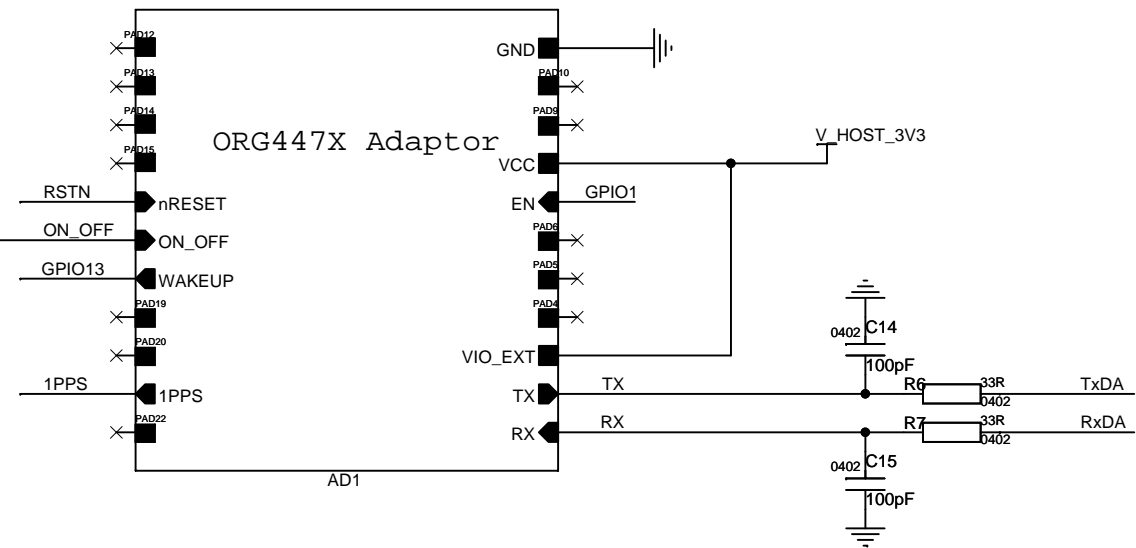
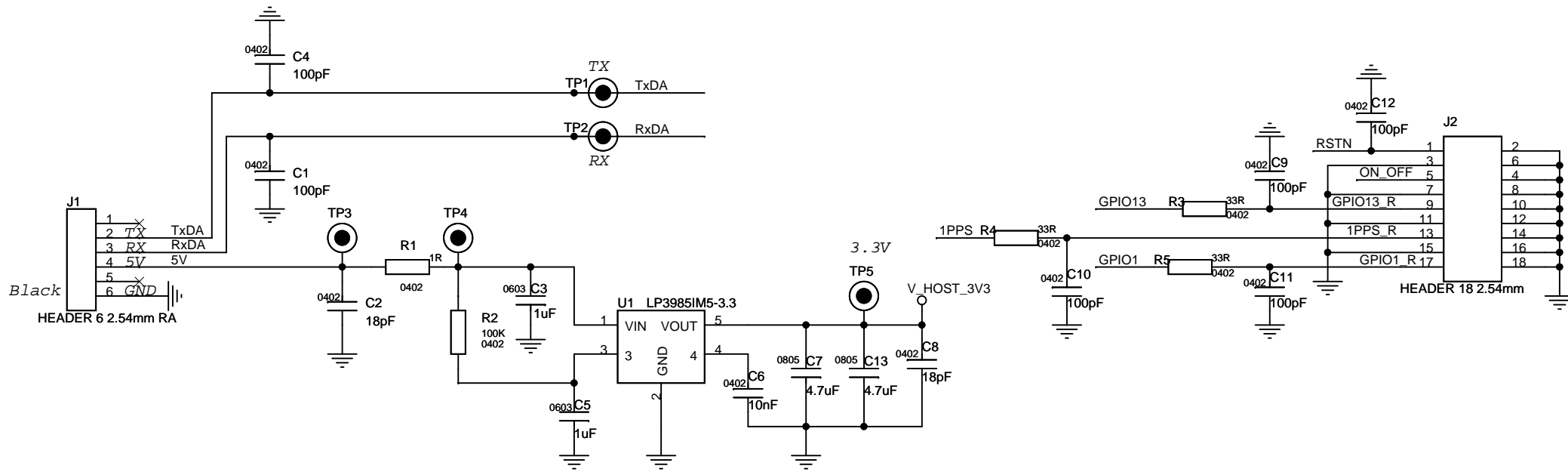

		Project	
		ORG447X UART Evaluation Kit	
Title			
ORG447X UART Demo Board			
Size	Document Number	Authored By:	Rev
A4	PD-ORG447X-AD1-DBUA	I. Divinsky	A00
Date:	Sunday, September 12, 2010		Sheet 1 of 1

Active Antenna Bias Assembly Option 5

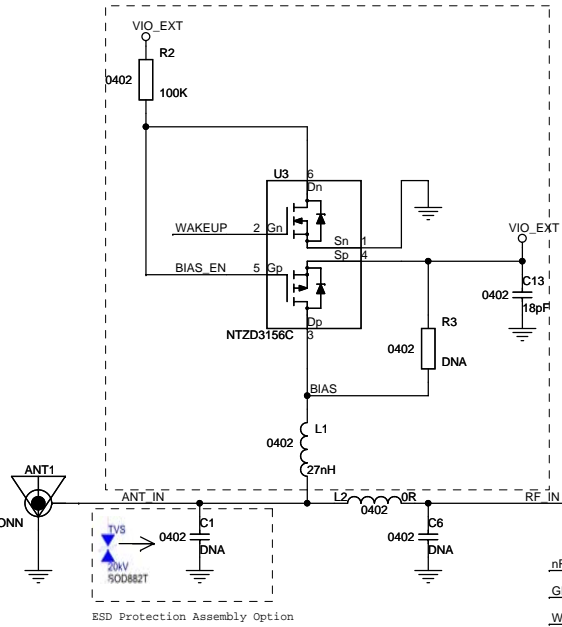

ESD Protection Assembly Option

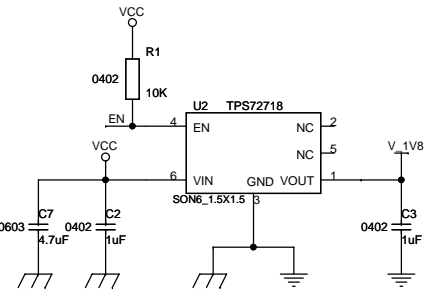
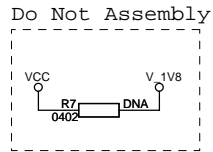

DC-DC Buck Regulator Assembly Option 2

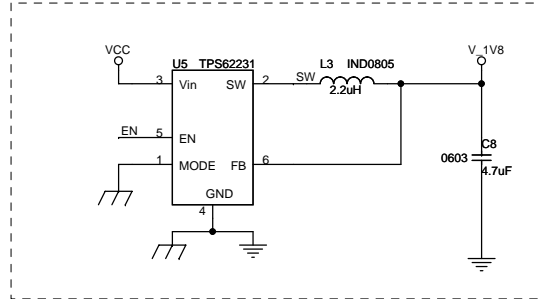

ON_OFF Rising Edge Generator Assembly Option 4

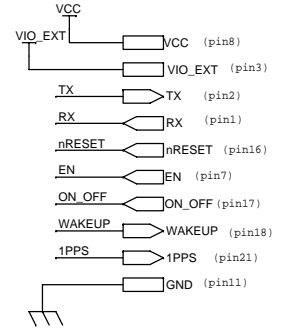
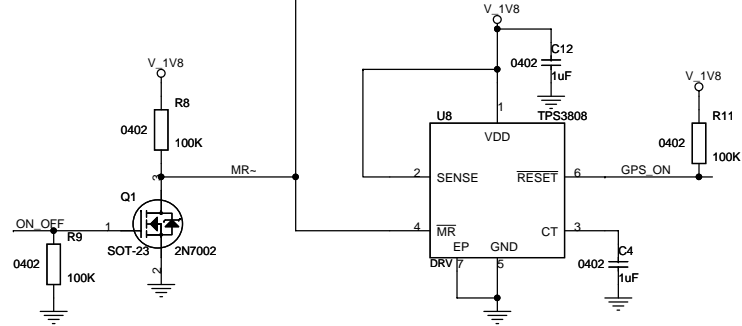
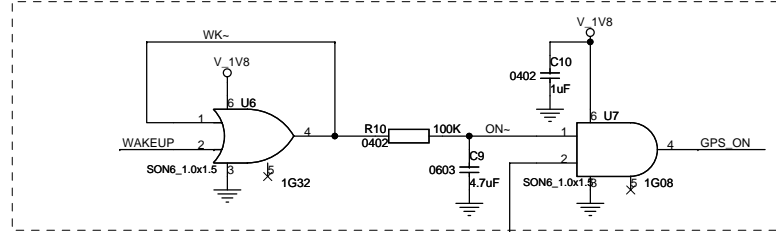

		Project	
		ORG447X-AD1	
Title			
ORG447X Adaptor			
Size	Document Number	Authored By:	Rev
A3	PD-ORG-447XAD1-A00	I. Divinsky	A00
Date:	Sunday, September 12, 2010	Sheet	1 of 1

3. Main Board Assembly Bill Of Materials

Item	Quantity	Reference	Value	Description	P/N	MFG
1	8	C1,C4,C9,C10,C11,C12,C14,C15	100pF	CAP SMT 100pF 50V 5% COG 0402	GRM1555C1H101JA01D	MURATA
2	2	C2,C8	18pF	CAP SMT 18pF 50V 5% COG 0402	GRM1555C1H180JZ01D	MURATA
3	1	C3,C5	1uF	CAP SMT 1uF 6.3V 10% X5R 0603	GRM188R60J105KA01D	MURATA
4	1	C6	10nF	CAP SMT 10nF 25V 10% X7R 0402	GRM155R71E103KA01D	MURATA
5	2	C7,C13	4.7uF	CAP SMT 4.7uF 6.3V 10% X5R 0805	GRM21BR61C475KA88B	MURATA
6	1	J1	HEADER 6 2.54mm RA	CONN. 6P TH RA	2211S-06G-F1	NELTRON
7	1	R1	1R	RESISTOR CHIP METAL FILM 0402 0.063W	CRCW04021RFRT1	VISHAY
8	1	R2	100K	RESISTOR CHIP METAL FILM 0402 0.063W	CRCW0402100KFRT1	VISHAY
9	5	R3,R4,R5,R6,R7	33R	RESISTOR CHIP METAL FILM 0402 0.063W	CRCW040233RFRT1	VISHAY
10	1	SW1	Tact Switch	SMD TACT SWITCH	TJ-532-V-T/R	DIPTRONICS
11	1	U1	LP3985IM5-3.3	3.3V LDO REGULATOR 200mA	LP3985IM5-3.3	NATIONAL

4. ORG447X Adaptor Assembly Bill Of Materials

Item	Quantity	Reference	Value	Description	P/N	MFG	Assembly Notes
1	1	ANT1	ANT_CONN	Ultra Small SMD Coaxial Conn.	W.FL	HIROSE	MAIN
2	1	C1	ESD1	Ceramic ESD protection device	LXE15AAA1-017	MURATA	Option 5
3	3	C2,C3,C5	1uF	CAP SMT 1uF 10V 10% X5R 0402	GRM155R61A105KE15	MURATA	MAIN
4	2	C4,C12	1uF	CAP SMT 1uF 10V 10% X5R 0402	GRM155R61A105KE15	MURATA	Option 3
5	1	C10	1uF	CAP SMT 1uF 10V 10% X5R 0402	GRM155R61A105KE15	MURATA	Option 4
6	1	C6	DNA	CAP SMT 1pF 50V 5% COG 0402	GRM1555C1H1RWZ01D	MURATA	Do Not Assembly
7	2	C7,C8	4.7uF	CAP SMT 4.7uF 6.3V 10% X5R 0603	GRM155R60G475ME87D	MURATA	MAIN
8	1	C9	4.7uF	CAP SMT 4.7uF 6.3V 10% X5R 0603	GRM155R60G475ME87D	MURATA	Option 4
9	1	C11	18pF	CAP SMT 18pF 50V 5% COG 0402	GRM1555C1H180JZ01D	MURATA	MAIN
10	1	C13	18pF	CAP SMT 18pF 50V 5% COG 0402	GRM1555C1H180JZ01D	MURATA	Option 5
11	1	L1	27nH	IND SMT 27nH 0402	LQG15HS27NJO2	MURATA	Option 5
12	2	L2,R6	0R	RESISTOR CHIP METAL FILM 0402 0.063W	CRCW04020RJK	VISHAY	MAIN
13	1	L3	2.2uH	SMD IND 2.2uH 0.74A DSR=0.1Ohm	LQM21PN2R2MCO	MURATA	Option 2
14	1	Q1	2N7002	N-CH 0.38A 60V SOT23 Power MOSFET	2N7002KT1G	ON	MAIN
15	3	R8,R9,R11	100K	RESISTOR CHIP METAL FILM 0402 0.063W	CRCW0402100KJK	VISHAY	MAIN
16	1	R2	100K	RESISTOR CHIP METAL FILM 0402 0.063W	CRCW0402100KJK	VISHAY	Option 5
17	1	R10	100K	RESISTOR CHIP METAL FILM 0402 0.063W	CRCW0402100KJK	VISHAY	Option 4
18	4	R3,R5,R7,R12	DNA	RESISTOR CHIP METAL FILM 0402 0.063W	CRCW0402100KJK	VISHAY	Do Not Assembly
19	2	R1,R4	10K	RESISTOR CHIP METAL FILM 0402 0.063W	CRCW040210KJK	VISHAY	MAIN
20	1	R13	33R	RESISTOR CHIP METAL FILM 0402 0.063W	CRCW040233RFRT1	VISHAY	MAIN
21	1	U1	ORG447X	Minuature GPS Engine Module	ORG447X	ORIGINGPS	MAIN
22	1	U2	TPS72718	1.8V Low Iq Low N RF LDO Regulator 200mA	TPS72718DSER	TI	Option 1
23	1	U3	NTZD3156C	Compl. N- P-Ch. MOSFET w Integr PUR PDR ESD Protection	NTZD3156CT1G	ON	Option 5
24	1	U4	NLU1GT125	Single Buffer W. 3-STATE	NLU1GT126CMX1TCG	ON	MAIN
25	1	U5	TPS62231	1.8V High Efficiency DC-DC Buck Converter	TPS62231DRYR	TI	Option 2
26	1	U6	1G32	Low Power Single OR Gate	SN74AUP1G32DRY	TI	Option 4
27	1	U7	1G08	Low Power Single AND Gate	SN74AUP1G08DRY	TI	Option 4
28	1	U8	TPS3808	Low Iq Programmable Delay Supervisor	TPS3808G18DRVR	TI	Option 3

5. Main Board PCB layout

UART Main Board for ORG447x Series Module Adaptor is 2 layers 1.6mm thickness FR4 PCB.

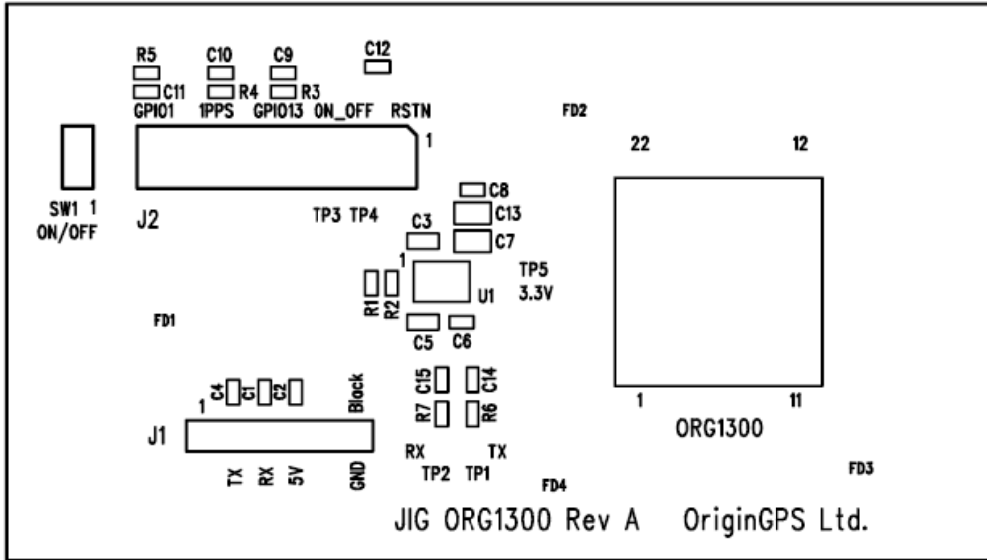

Components Placement

6. ORG447X Adaptor PCB layout

Adaptor Board for ORG447x Series Modules is 4 layers 0.6mm thickness FR4 PCB.

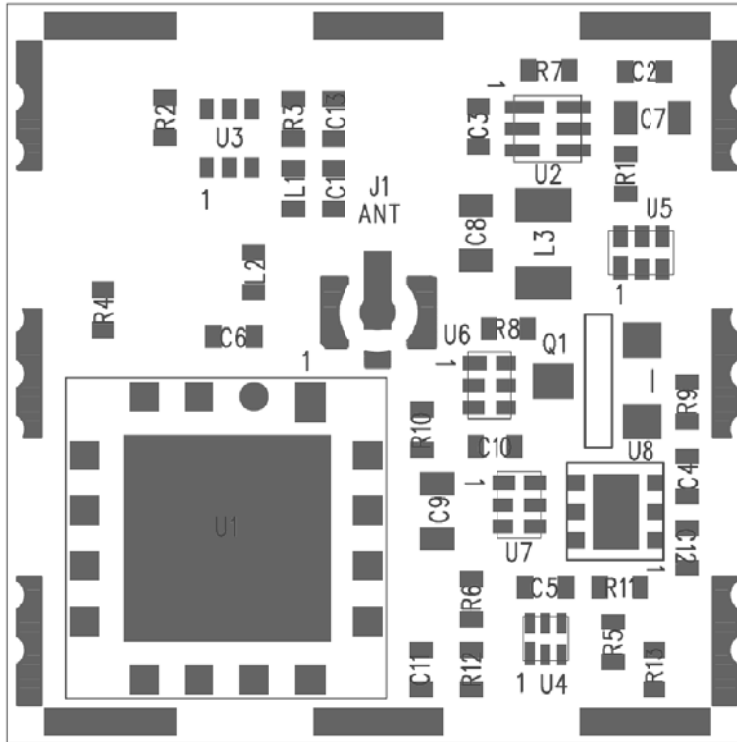

Components Placement

7. TTL-232R-3V3 USB-Serial Converter

The TTL-232R-3V3 is a USB to Serial (TTL level) converter cable which allows for a simple way to connect TTL interface devices to USB.

The TTL-232R-3V3 uses an FTDI FT232RQ IC which is housed inside the USB 'A' connector and is terminated at the end of a 1.8 meter cable (6 ft.) with a 0.1" pitch header socket which provided access to transmit (Tx), receive (Rx), RTS# and CTS#. These lines all operate at 3.3V levels. Also brought out on the header are VCC (5V) and GND.

The mechanical details of the 6 way connector are shown in the following diagram

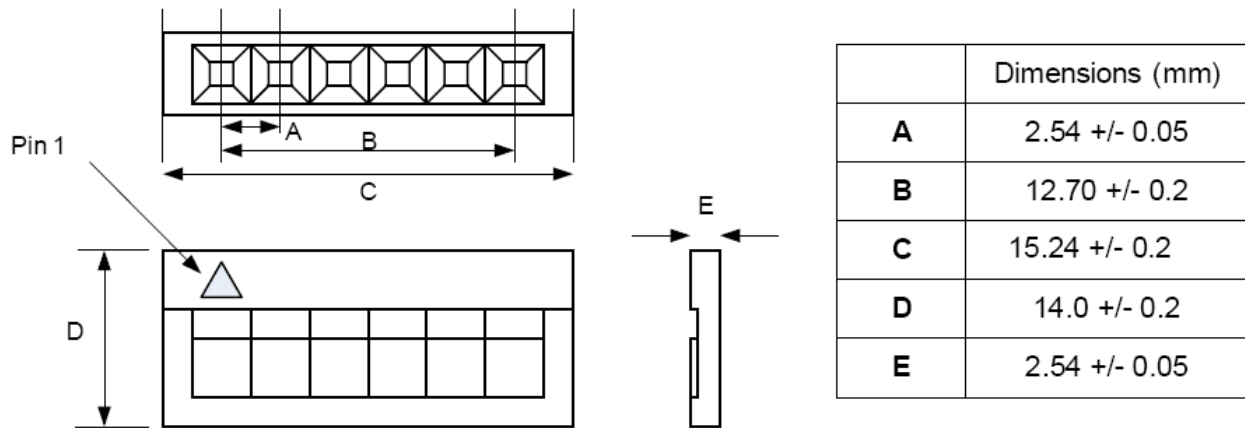

Header Pin Number	Name	Type	Colour	Description
1	GND	GND	Black	Device ground supply pin.
2	CTS#	Input	Brown	Clear to Send Control input / Handshake signal.
3	VCC	Output	Red	+5V output,

Header Pin Number	Name	Type	Colour	Description
4	TXD	Output	Orange	Transmit Asynchronous Data output.
5	RXD	Input	Yellow	Receive Asynchronous Data input.
6	RTS#	Output	Green	Request To Send Control Output / Handshake signal.