

# GE865 Hardware User Guide

1wv0300799 Rev.12 – 27-07-2010



## APPLICABILITY TABLE

PRODUCT
GE865



## DISCLAIMER

The information contained in this document is the proprietary information of Telit Communications S.p.A. and its affiliates ("TELIT"). The contents are confidential and any disclosure to persons other than the officers, employees, agents or subcontractors of the owner or licensee of this document, without the prior written consent of Telit, is strictly prohibited.

Telit makes every effort to ensure the quality of the information it makes available. Notwithstanding the foregoing, Telit does not make any warranty as to the information contained herein, and does not accept any liability for any injury, loss or damage of any kind incurred by use of or reliance upon the information.

Telit disclaims any and all responsibility for the application of the devices characterized in this document, and notes that the application of the device must comply with the safety standards of the applicable country, and where applicable, with the relevant wiring rules.

Telit reserves the right to make modifications, additions and deletions to this document due to typographical errors, inaccurate information, or improvements to programs and/or equipment at any time and without notice. Such changes will, nevertheless be incorporated into new editions of this application note.

All rights reserved.

© 2009, 2010 Telit Communications S.p.A.



# Contents

APPLICABILITY TABLE.....	2
<b>1 INTRODUCTION .....</b>	<b>7</b>
1.1 SCOPE .....	7
1.2 AUDIENCE.....	7
1.3 CONTACT INFORMATION, SUPPORT .....	7
1.4 DOCUMENT ORGANIZATION .....	8
1.5 TEXT CONVENTIONS.....	9
1.6 RELATED DOCUMENTS .....	9
1.7 DOCUMENT HISTORY .....	10
<b>2 OVERVIEW .....</b>	<b>11</b>
<b>3 GE865 MECHANICAL DIMENSIONS.....</b>	<b>13</b>
<b>4 GE865 MODULE CONNECTIONS .....</b>	<b>14</b>
4.1 PIN-OUT.....	14
<i>4.1.1 BGA Balls Layout .....</i>	<i>17</i>
<b>5 HARDWARE COMMANDS .....</b>	<b>18</b>
5.1 TURNING ON THE GE865.....	18
5.2 TURNING OFF THE GE865 .....	23
5.3 RESETTING THE GE865.....	25
<i>5.3.1 Hardware Unconditional restart.....</i>	<i>25</i>
<b>6 POWER SUPPLY .....</b>	<b>28</b>
6.1 POWER SUPPLY REQUIREMENTS.....	28
6.2 POWER CONSUMPTION .....	29
6.3 GENERAL DESIGN RULES .....	30
<i>6.3.1 Electrical Design Guidelines .....</i>	<i>30</i>
<i>6.3.2 Thermal Design Guidelines.....</i>	<i>34</i>
<i>6.3.3 Power Supply PCB layout Guidelines.....</i>	<i>35</i>
<b>7 ANTENNA.....</b>	<b>36</b>
7.1 GSM ANTENNA REQUIREMENTS.....	36
7.2 GSM ANTENNA - PCB LINE GUIDELINES.....	37
7.3 GSM ANTENNA - INSTALLATION GUIDELINES.....	38
<b>8 LOGIC LEVEL SPECIFICATIONS .....</b>	<b>39</b>
8.1 RESET SIGNAL .....	40
<b>9 SERIAL PORTS.....</b>	<b>41</b>
9.1 MODEM SERIAL PORT .....	41



9.2 RS232 LEVEL TRANSLATION .....	43
9.3 5V UART LEVEL TRANSLATION .....	46
<b>10 AUDIO SECTION OVERVIEW .....</b>	<b>48</b>
10.1 ELECTRICAL CHARACTERISTICS .....	49
10.1.1 Input Lines .....	49
10.1.2 Output Lines .....	50
<b>11 GENERAL PURPOSE I/O .....</b>	<b>51</b>
11.1 GPIO LOGIC LEVELS .....	52
11.2 USING A GPIO PAD AS INPUT .....	53
11.3 USING A GPIO PAD AS OUTPUT .....	53
11.4 USING THE RF TRANSMISSION CONTROL GPIO4 .....	53
11.5 USING THE RFTXMON OUTPUT GPIO5 .....	54
11.6 USING THE ALARM OUTPUT GPIO6 .....	54
11.7 USING THE BUZZER OUTPUT GPIO7 .....	55
11.8 MAGNETIC BUZZER CONCEPTS .....	56
11.8.1 Short Description .....	56
11.8.2 Frequency Behaviour .....	57
11.8.3 Power Supply Influence .....	57
11.8.4 Working Current Influence .....	57
11.9 INDICATION OF NETWORK SERVICE AVAILABILITY .....	58
11.10 RTC BYPASS OUT .....	59
11.11 EXTERNAL SIM HOLDER IMPLEMENTATION .....	59
<b>12 DAC AND ADC SECTION .....</b>	<b>60</b>
12.1 DAC CONVERTER .....	60
12.1.1 Description .....	60
12.1.2 Enabling DAC .....	61
12.1.3 Low Pass Filter Example .....	61
12.2 ADC CONVERTER .....	62
12.2.1 Description .....	62
12.2.2 Using ADC Converter .....	62
<b>13 MOUNTING THE GE865 ON YOUR BOARD .....</b>	<b>63</b>
13.1 GENERAL .....	63
13.2 MODULE FINISHING & DIMENSIONS .....	63
13.3 RECOMMENDED FOOT PRINT FOR THE APPLICATION .....	64
13.4 DEBUG OF THE GE865 IN PRODUCTION .....	65
13.5 STENCIL .....	65
13.6 PCB PAD DESIGN .....	66
13.7 SOLDER PASTE .....	67
13.7.1 GE865 Solder reflow .....	68
<b>14 PACKING SYSTEM .....</b>	<b>70</b>
14.1 PACKING ON TRAY .....	70
14.1.1 Tray detail .....	71



**GE865 Hardware User Guide**  
 1vv0300799 Rev.12 – 27-07-2010

14.2	PACKAGING ON REEL .....	72
14.2.1	<i>Carrier Tape detail</i> .....	72
14.2.2	<i>Reel detail</i> .....	73
14.2.3	<i>Packaging detail</i> .....	74
14.3	MOISTURE SENSIBILITY .....	74
<b>15</b>	<b>CONFORMITY ASSESSMENT ISSUES</b> .....	<b>75</b>
<b>16</b>	<b>SAFETY RECOMMANDATIONS</b> .....	<b>77</b>



# 1 Introduction

## 1.1 Scope

The aim of this document is the description of some hardware solutions useful for developing a product with the Telit GE865 module.

## 1.2 Audience

This document is intended for Telit customers, who are integrators, about to implement their applications using our GE865 modules.

## 1.3 Contact Information, Support

For general contact, technical support, to report documentation errors and to order manuals, contact Telit's Technical Support Center (TTSC) at:

[TS-EMEA@telit.com](mailto:TS-EMEA@telit.com)  
[TS-NORTHAMERICA@telit.com](mailto:TS-NORTHAMERICA@telit.com)  
[TS-LATINAMERICA@telit.com](mailto:TS-LATINAMERICA@telit.com)  
[TS-APAC@telit.com](mailto:TS-APAC@telit.com)

Alternatively, use:

<http://www.telit.com/en/products/technical-support-center/contact.php>

For detailed information about where you can buy the Telit modules or for recommendations on accessories and components visit:

<http://www.telit.com>

To register for product news and announcements or for product questions contact Telit's Technical Support Center (TTSC).

Our aim is to make this guide as helpful as possible. Keep us informed of your comments and suggestions for improvements.

Telit appreciates feedback from the users of our information.



## 1.4 Document Organization

This document contains the following chapters:

Chapter 1: “Introduction” provides a scope for this document, target audience, contact and support information, and text conventions.

Chapter 2: “Overview” provides an overview of the document.

Chapter 3: “GE865 Mechanical Dimensions”

Chapter 4: “GE865 Module Connections” deals with the pin out configuration and layout.

Chapter 5: “Hardware Commands” How to operate on the module via hardware.

Chapter 6: “Power supply” Power supply requirements and general design rules.

Chapter 7: “Antenna” The antenna connection and board layout design are the most important parts in the full product design.

Chapter 8: “Logic Level specifications” Specific values adopted in the implementation of logic levels for this module.

Chapter 9: “Serial ports” The serial port on the Telit GE865 is the core of the interface between the module and OEM hardware

Chapter 10: “Audio Section overview” Refers to the audio blocks of the Base Band Chip of the GE865 Telit Modules.

Chapter 11: “General Purpose I/O” How the general purpose I/O pads can be configured.

Chapter 12 “DAC and ADC Section” Deals with these two kind of converters.

Chapter 13: “Mounting the GE865 on the application board” Recommendations and specifics on how to mount the module on the user’s board.



## 1.5 Text Conventions



***Danger – This information MUST be followed or catastrophic equipment failure or bodily injury may occur.***



***Caution or Warning – Alerts the user to important points about integrating the module, if these points are not followed, the module and end user equipment may fail or malfunction.***



**Tip or Information – Provides advice and suggestions that may be useful when integrating the module.**

All dates are in ISO 8601 format, i.e. YYYY-MM-DD.

## 1.6 Related Documents

- Telit's GSM/GPRS Family Software User Guide, [1v0300784](#)
- Audio settings application note , [80000NT10007a](#)
- Digital Voice Interface Application Note, [80000NT10004a](#)
- GE865 Product description,
- SIM Holder Design Guides, [80000NT10001a](#)
- AT Commands Reference Guide, [80000ST10025a](#)
- Telit EVK2 User Guide, [1v0300704](#)



## 1.7 Document History

Revision	Date	Changes
ISSUE#0	2009-01-26	First ISSUE# 0 - DRAFT
ISSUE#1	2009-02-15	Updated current consumptions table
ISSUE#2	2009-02-15	Updated Pinout description
ISSUE#3	2009-03-18	Updated mechanical dimensions (balls spacing), charger description removed, Added better explanation of pin H5 (RF) and H1 (service)
ISSUE#4	2009-04-02	Updated VBATT supply Range, DAC schematic, Conformity assessment
ISSUE#5	03/06/2009	Updated section 13 (FCC Conformity assessment)
ISSUE#6	04/06/2009	Updated section 13 (FCC Conformity assessment)
ISSUE#7	2009-05-26	Applied new layout + minor editing Edited PCB pad design par.13.1.6
ISSUE#8	2009-06-18	Updated all schematic drawings Updated Chapter 10 Audio Section Substituted GE865-QUAD with GE865 Corrected GE864-QUAD/PY with GE865 Updated Overview section
ISSUE#9	2009-07-27	Changed par. 5.1 Turning ON.... and par. 6.1 Power supply Requirements Changed par. 13.3 and par.15 Conformity Assessment Issues
ISSUE#10	2009-09-22	Added DVI pins description Updated table of power consumptions. Added note on chapters 5.1, 5.2, 9.3 Corrected chapter 1.1
ISSUE#11	2010-07-12	Updated logic levels specification Added NOTE on ON_OFF procedure, serial port , GPIO section Corrected note on RESET section Updated Current Consumptions Updated flow charts for ON OFF and Reset Updated name for Auxiliary UART port Updated Chapter 7 Updated Chapter 14
ISSUE#12	2010-07-28	Updated Chapters 13.2, 13.5, 13.6, 14, 14.3.



## 2 Overview

The aim of this document is the description of some hardware solutions useful for developing a product with the Telit GE865 module.

In this document all the basic functions of a mobile phone will be taken into account; for each one of them a proper hardware solution will be suggested and eventually the wrong solutions and common errors to be avoided will be evidenced. Obviously this document cannot embrace the whole hardware solutions and products that may be designed. The wrong solutions to be avoided shall be considered as mandatory, while the suggested hardware configurations shall not be considered mandatory, instead the information given shall be used as a guide and a starting point for properly developing your product with the Telit GE865 module. For further hardware details that may not be explained in this document refer to the Telit GE865 Product Description document where all the hardware information is reported.



### NOTICE:

(EN) The integration of the GSM/GPRS **GE865** cellular module within user application shall be done according to the design rules described in this manual.

(IT) L'integrazione del modulo cellulare GSM/GPRS **GE865** all'interno dell'applicazione dell'utente dovrà rispettare le indicazioni progettuali descritte in questo manuale.

(DE) Die Integration des **GE865** GSM/GPRS Mobilfunk-Moduls in ein Gerät muß gemäß der in diesem Dokument beschriebenen Konstruktionsregeln erfolgen.

(SL) Integracija GSM/GPRS **GE865** modula v uporabniški aplikaciji bo morala upoštevati projektna navodila, opisana v tem piro niku.

(SP) La utilización del modulo GSM/GPRS **GE865** debe ser conforme a los usos para los cuales ha sido diseñado descritos en este manual del usuario.

(FR) L'intégration du module cellulaire GSM/GPRS **GE865** dans l'application de l'utilisateur sera faite selon les règles de conception décrites dans ce manuel.

(HE) האינטגרציה של המודול הסלולרי **GE865-QUAD** עם המוצר. תהיה בהתאם לכללי האינטגרציה של המודול הסלולרי.

The information presented in this document is believed to be accurate and reliable. However, no responsibility is assumed by Telit Communications S.p.A. for its use, nor



**GE865 Hardware User Guide**  
1vv0300799 Rev.12 – 27-07-2010

any infringement of patents or other rights of third parties which may result from its use. No license is granted by implication or otherwise under any patent rights of Telit Communications S.p.A. other than for circuitry embodied in Telit products. This document is subject to change without notice.



# 3 GE865 Mechanical Dimensions

The GE865 overall dimensions are:

- Length: 22 mm
- Width: 22 mm
- Thickness: 3.0 mm

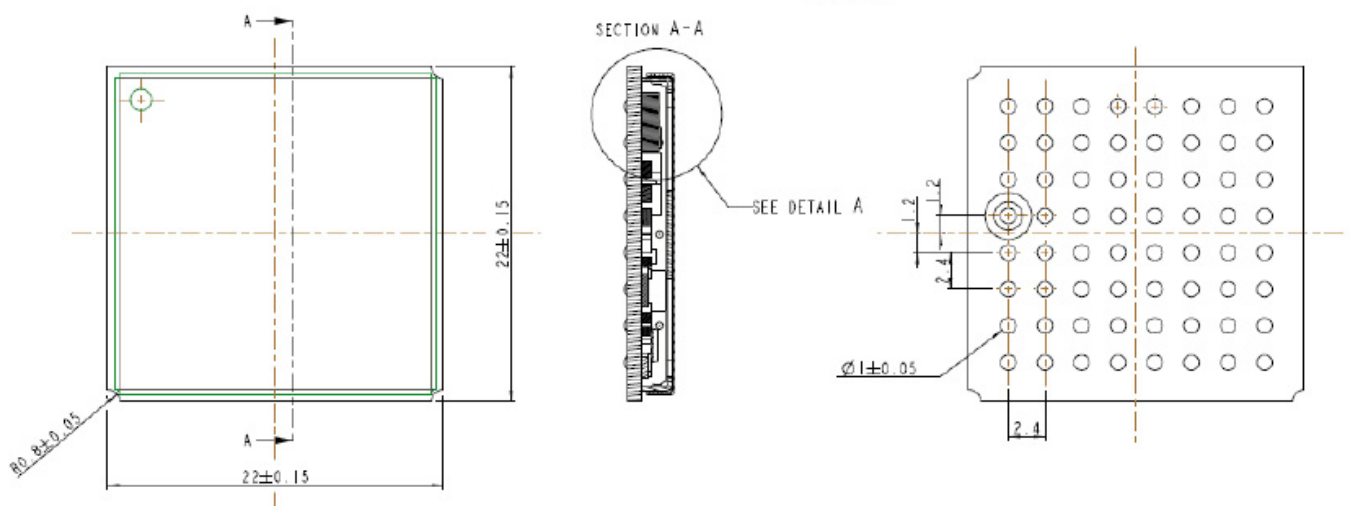
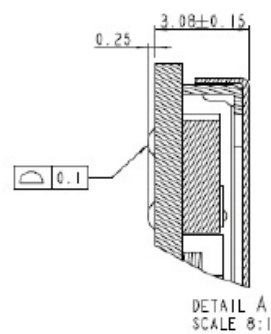

## 4 GE865 module connections

### 4.1 PIN-OUT

Ball	Signal	I/O	Function	Note	Type
<b>Audio</b>					
E8	EAR-	A0	Earphone signal output, phase -		Audio
D8	EAR+	A0	Earphone signal output, phase +		Audio
B8	MIC+	AI	Mic.signal input; phase+		Audio
C8	MIC-	AI	Mic.signal input; phase-		Audio
<b>SIM card interface</b>					
A5	SIMCLK	O	External SIM signal – Clock		1,8 / 3V
A8	SIMRST	O	External SIM signal – Reset		1,8 / 3V
A6	SIMIO	I/O	External SIM signal – Data I/O	4.7K Pull up	1,8 / 3V
B7	SIMIN	I	External SIM signal – Presence (active low)		1,8 / 3V
A7	SIMVCC	-	External SIM signal – Power supply for the SIM		1,8 / 3V
<b>Trace</b>					
D1	TX_AUX	O	Auxiliary UART (TX Data to DTE)		CMOS 2.8V
E1	RX_AUX	I	Auxiliary UART (RX Data from DTE)		CMOS 2.8V
<b>Prog. / Data + HW Flow Control</b>					
A3	C103/TXD	I	Serial data input (TXD) from DTE		CMOS 2.8V
A4	C104/RXD	O	Serial data output to DTE		CMOS 2.8V
B3	C108/DTR	I	Input for Data terminal ready signal (DTR) from DTE		CMOS 2.8V
A1	C105/RTS	I	Input for Request to send signal (RTS) from DTE		CMOS 2.8V
A2	C106/CTS	O	Output for Clear to send signal (CTS) to DTE		CMOS 2.8V
B5	C109/DCD	O	Output for Data carrier detect signal (DCD) to DTE		CMOS 2.8V
B2	C107/DSR	O	Output for Data set ready signal (DSR) to DTE		CMOS 2.8V
B4	C125/RING	O	Output for Ring indicator signal (RI) to DTE		CMOS 2.8V
<b>DAC and ADC</b>					
G7	DAC_OUT	A0	Digital/Analog converter output		D/A
F5	ADC_IN1	AI	Analog/Digital converter input		A/D
F6	ADC_IN2	AI	Analog/Digital converter input		A/D
<b>Miscellaneous Functions</b>					
C1	RESET*	I	Reset input		
H2	VRTC	AI/O	VRTC Backup capacitor		Power
G8	STAT_LED	O	Status indicator led		CMOS 1.8V
B1	ON_OFF*	I	Input command for switching power ON or OFF (toggle command).	47K Pull Up	Pull up to VRTC
E2	PWRMON	O	Power ON Monitor		CMOS 2.8V







---

**WARNING:**Reserved pins must not be connected.

---



---

**NOTE:**

If not used, almost all pins should be left disconnected. The only exceptions are the following pins:

pin	signal
F1,F2,F3	VBATT & VBATT_PA
G1, C2, C7, E5, E7, G5, G4, G3, H3, H6	GND
B1	ON/OFF*
A3	TXD
C1	RESET*
A4	RXD
A1	RTS
D1	TXD_AUX
E1	RXD_AUX
H1	Service

---

RTS pin should be connected to the GND (on the module side) if flow control is not used

---



### 4.1.1 BGA Balls Layout

**TOP VIEW**

	A	B	C	D	E	F	G	H
1	C105 / RTS	ON_OFF	RESET*	TX_AUX	RX_AUX	VBATT	GND	SERVICE
2	C106/CTS	C107/DSR	GND	GPIO_02 / DVI_RX	PWRMON	VBATT_PA	GPIO_05	VRTC
3	C103_TXD	C108/DTR	-	GPIO_01 / DVI_WA0	GPIO_10	VBATT_PA	GND	GND
4	C104/RXD	C125/RING	-	GPIO_08 / DVI_CLK	GPIO_03 / DVI_TX	GPIO_09	GND	
5	SIMCLK	C109/DCD	-	-	GND	ADC1	GND	ANT
6	SIMIO	-	-	-	-	ADC2	GPIO_07	GND
7	SIMVCC	SIMIN	GND	-	GND	-	DAC	GPIO_04
8	SIMRST	MIC+	MIC-	EAR+	EAR-	-	STATLED	GPIO_06

**LEGENDA:**

<b>AUDIO</b>	<b>MISCELLANEOUS</b>
SIM CARD	GPIO
ANTENNA	POWER SUPPLY VBATT
UARTS	POWER SUPPLY GND
DAC and ADC	RESERVED



**NOTE:**

The pin defined as H4 has to be considered RESERVED and not connected on any pin in the application. The related area on the application has to be kept empty.



# 5 Hardware Commands

## 5.1 Turning ON the GE865

To turn on the GE865 the pad ON# must be tied low for at least 1 second and then released.

When the power supply voltage is lower than 3.4V the pad ON# must be tied low at least 3 seconds.

The maximum current that can be drained from the ON# pad is 0,1 mA.  
A simple circuit to do it is:

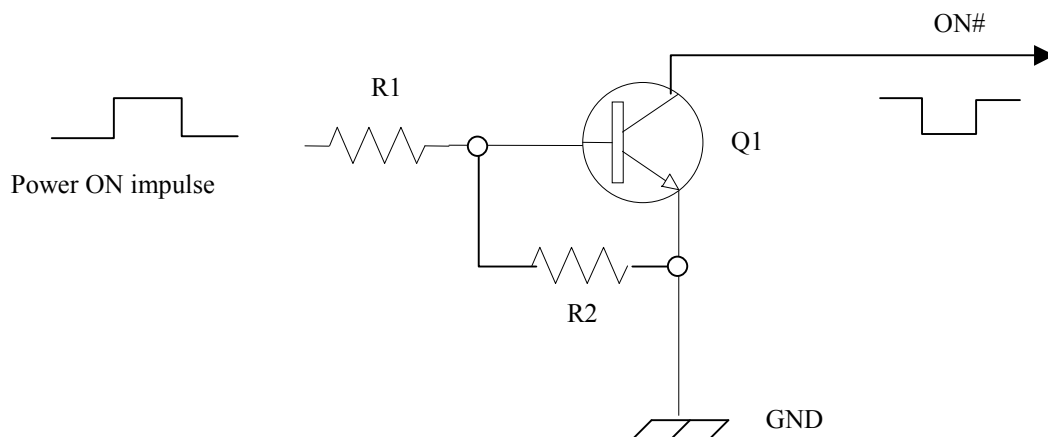

**NOTE:**

Don't use any pull up resistor on the ON# line, it is internally pulled up. Using pull up resistor may bring to latch up problems on the GE865 power regulator and improper power on/off of the module. The line ON# must be connected only in open collector configuration.





---

**NOTE:**

In this document all the lines that are inverted, hence have active low signals are labelled with a name that ends with "#" or with a bar over the name.

---



---

**TIP:**

To check if the device has powered on, the hardware line PWRMON should be monitored. After 900ms the line raised up the device could be considered powered on.

---



---

**NOTE:**

It is mandatory to avoid sending data to the serial ports during the first 200mS of the module startup.

---



A flow chart showing the proper turn on procedure is displayed below:

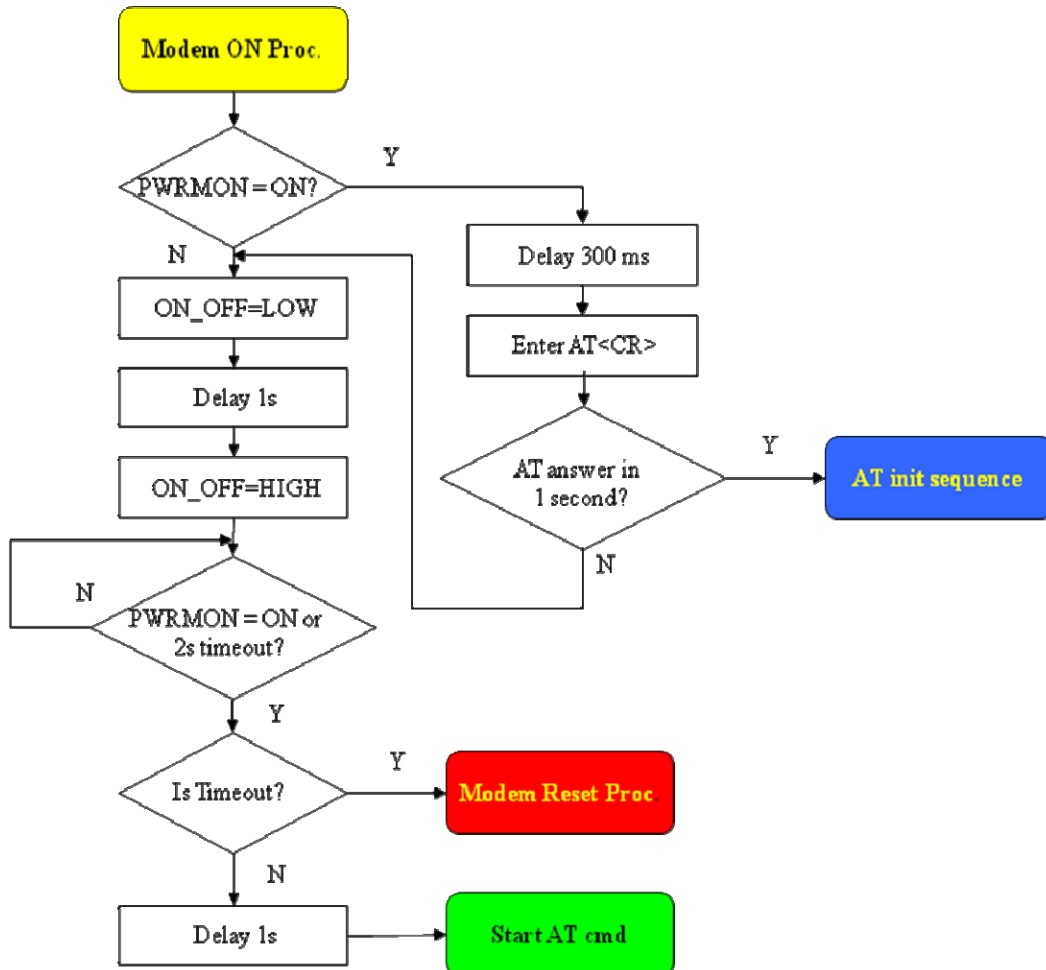

**NOTE:**



In order to avoid a back powering effect it is recommended to avoid having any HIGH logic level signal applied to the digital pins of the GE865 when the module is powered off or during an ON/OFF transition.





For example:

1- Let's assume you need to drive the ON# pad with a totem pole output of a +3/5 V microcontroller (uP\_OUT1):

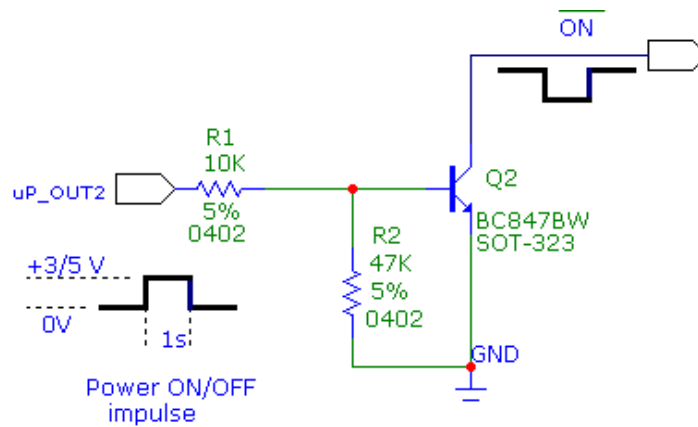

2- Let's assume you need to drive the ON# pad directly with an ON/OFF button:

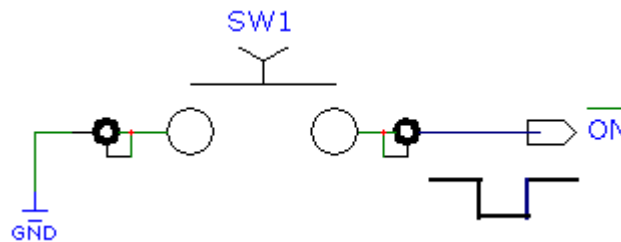

## 5.2 Turning OFF the GE865

Turning off of the device can be done in two ways:

- via AT command (see GE865 Software User Guide, AT#SHDN)
- by tying low pin ON#

Either ways, the device issues a detach request to network informing that the device will not be reachable any more.

To turn OFF the GE865 the pad ON# must be tied low for at least 2 seconds and then released. A Pulse duration less than 2 seconds should also start the power off procedure, but this is not guaranteed. The same circuitry and timing for the power on must be used. The device shuts down after the release of the ON# pad.



The following flow chart shows the proper turnoff procedure:

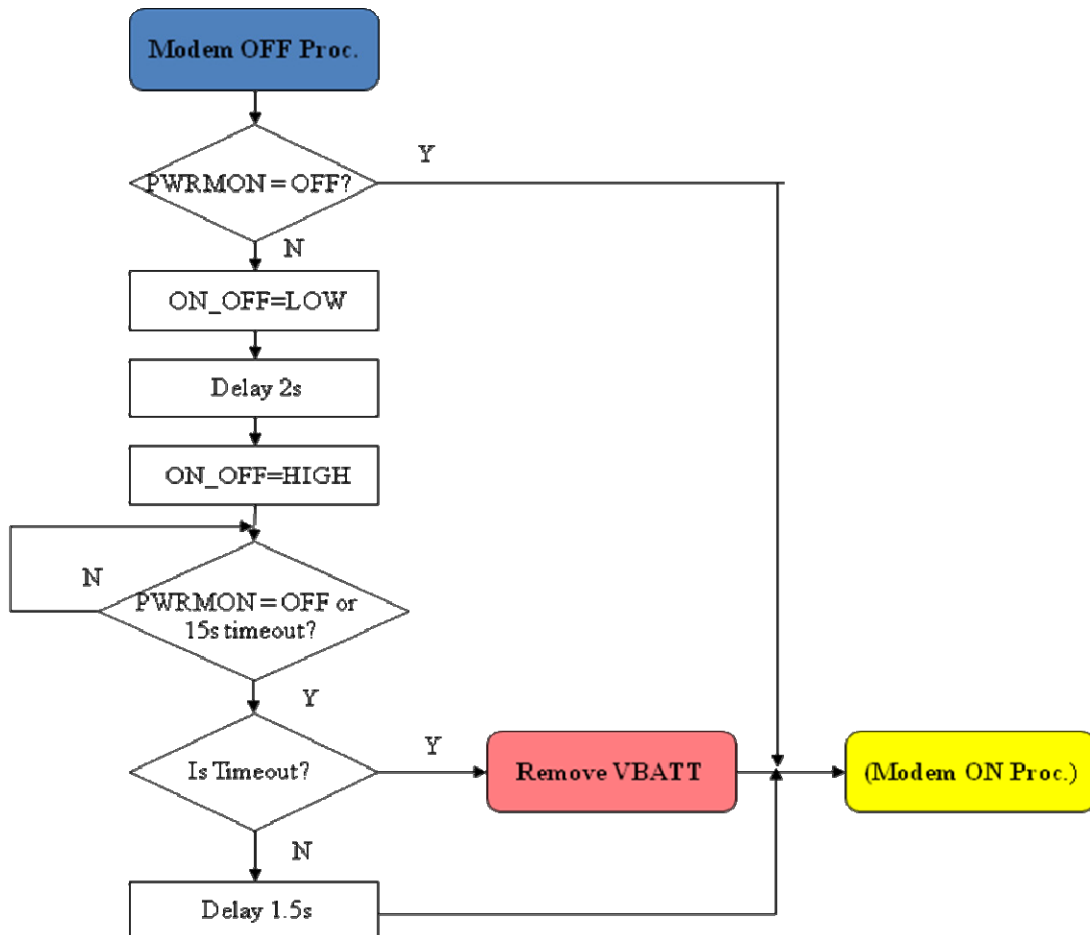

**TIP:**

To check if the device has been powered off, the hardware line PWRMON must be monitored. The device is powered off when PWRMON goes low.



**NOTE:**

In order to avoid a back powering effect it is recommended to avoid having any HIGH logic level signal applied to the digital pins of the GE865 when the module is powered off or during an ON/OFF transition.



## 5.3 Resetting the GE865

### 5.3.1 Hardware Unconditional restart



**WARNING:**

The hardware unconditional Restart must not be used during normal operation of the device since it does not detach the device from the network. It shall be kept as an emergency exit procedure to be done in the rare case that the device gets stacked waiting for some network or SIM responses.

To unconditionally reboot the GE865, the pad RESET# must be tied low for at least 200 milliseconds and then released.

The maximum current that can be drained from the RESET# pad is 0,15 mA.



**NOTE:**

Do not use any pull up resistor on the RESET\* line nor any totem pole digital output. Using pull up resistor may bring to latch up problems on the GE865 power regulator and improper functioning of the module. The line RESET\* must be connected only in open collector configuration.

**TIP:**

The unconditional hardware restart must always be implemented on the boards and the software must use it as an emergency exit procedure.

A simple circuit to do it is:

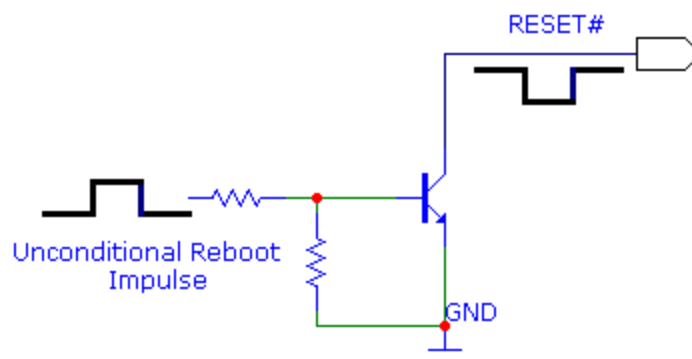

In the following flow chart is detailed the proper restart procedure:

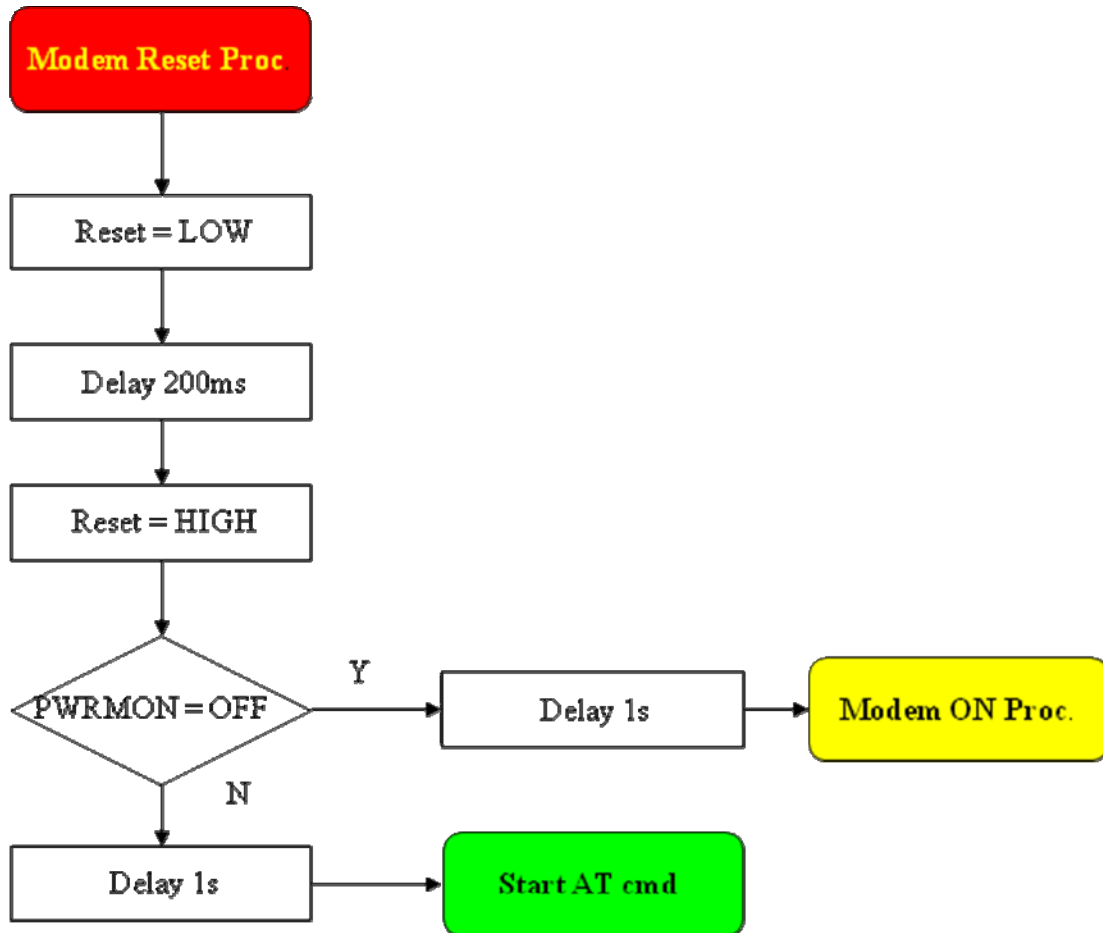

**NOTE:**

In order to avoid a back powering effect it is recommended to avoid having any HIGH logic level signal applied to the digital pins of the GE865 when the module is powered off or during an ON/OFF transition.



For example:

- 1- Let us assume you need to drive the RESET# pad with a totem pole output of a +3/5 V microcontroller (uP\_OUT2):

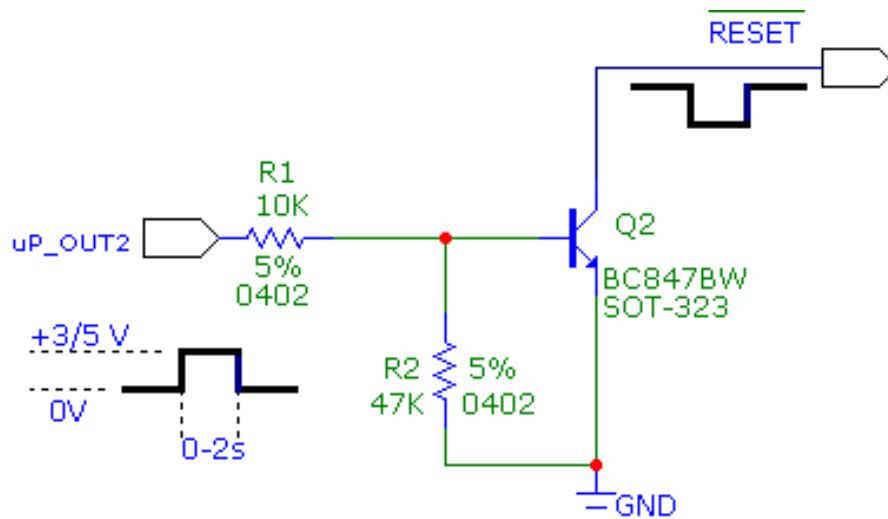







An example of linear regulator with 5V input is:

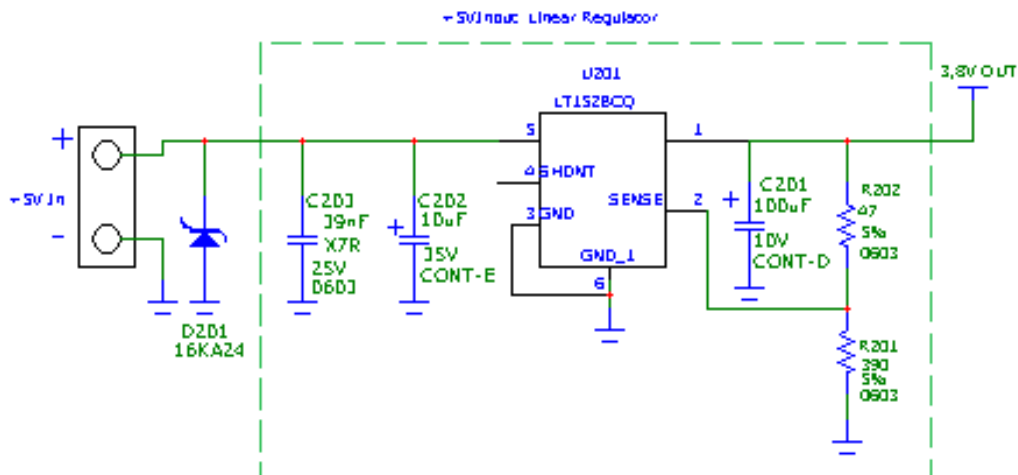

### 6.3.1.2 + 12V input Source Power Supply Design Guidelines

- The desired output for the power supply is 3.8V, hence due to the big difference between the input source and the desired output, a linear regulator is not suited and shall not be used. A switching power supply will be preferable because of its better efficiency especially with the 2A peak current load represented by the GE865.
- When using a switching regulator, a 500kHz or more switching frequency regulator is preferable because of its smaller inductor size and its faster transient response. This allows the regulator to respond quickly to the current peaks absorption.
- In any case the frequency and Switching design selection is related to the application to be developed due to the fact the switching frequency could also generate EMC interferences.
- For car PB battery the input voltage can rise up to 15,8V and this should be kept in mind when choosing components: all components in the power supply must withstand this voltage.
- A Bypass low ESR capacitor of adequate capacity must be provided in order to cut the current absorption peaks, a 100µF tantalum capacitor is usually suited.
- Make sure the low ESR capacitor on the power supply output (usually a tantalum one) is rated at least 10V.
- For Car applications a spike protection diode should be inserted close to the power input, in order to clean the supply from spikes.



**GE865 Hardware User Guide**  
1v0300799 Rev.12 – 27-07-2010

- A protection diode should be inserted close to the power input, in order to save the GE865 from power polarity inversion. This can be the same diode as for spike protection.

An example of switching regulator with 12V input is in the below schematic (split in 2 parts):

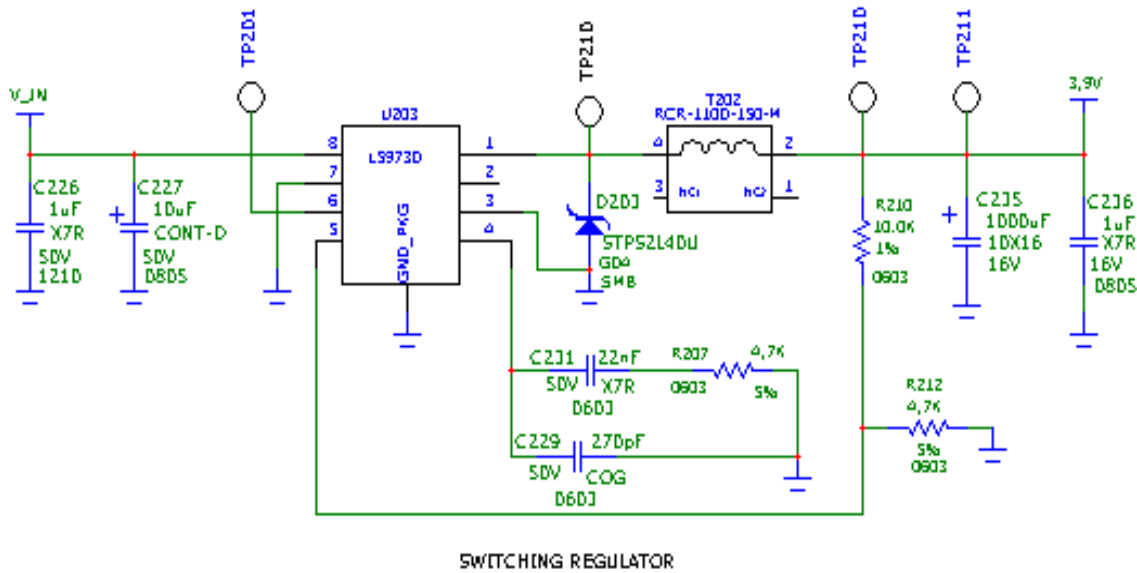
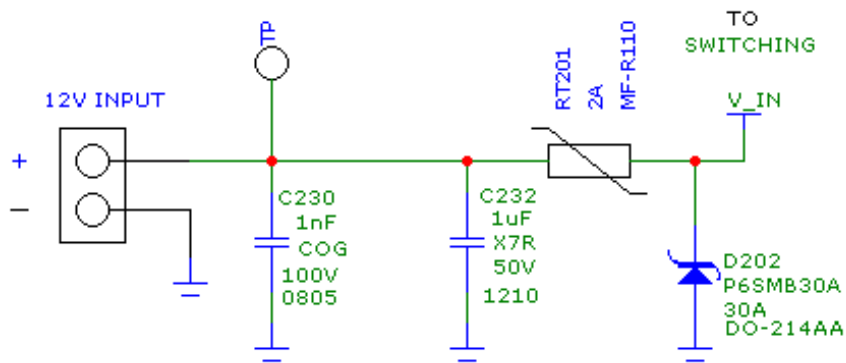

SWITCHING REGULATOR



### 6.3.1.3 Battery Source Power Supply Design Guidelines

- The desired nominal output for the power supply is 3.8V and the maximum voltage allowed is 4.2V, hence a single 3.7V Li-Ion cell battery type is suited for supplying the power to the Telit GE865 module.



---

#### WARNING:

The three cells Ni/Cd or Ni/MH 3,6 V Nom. battery types or 4V PB types ***MUST NOT BE USED DIRECTLY*** since their maximum voltage can rise over the absolute maximum voltage for the GE865 and damage it.

---



---

#### NOTE:

DON'T USE any Ni-Cd, Ni-MH, and Pb battery types directly connected with GE865. Their use can lead to overvoltage on the GE865 and damage it. USE ONLY Li-Ion battery types.

---

- A Bypass low ESR capacitor of adequate capacity must be provided in order to cut the current absorption peaks, a 100µF tantalum capacitor is usually suited.
- Make sure the low ESR capacitor (usually a tantalum one) is rated at least 10V.
- A protection diode should be inserted close to the power input, in order to save the GE865 from power polarity inversion. Otherwise the battery connector should be done in a way to avoid polarity inversions when connecting the battery.
- The battery capacity must be at least 500mAh in order to withstand the current peaks of 2A; the suggested capacity is from 500mAh to 1000mAh.







# 7 Antenna

The antenna connection and board layout design are the most important aspect in the full product design as they strongly affect the product overall performances, hence read carefully and follow the requirements and the guidelines for a proper design.

## 7.1 GSM Antenna Requirements

As suggested on the Product Description the antenna and antenna transmission line on PCB for a Telit GE865 device shall fulfil the following requirements:

ANTENNA REQUIREMENTS	
Frequency range	Depending by frequency band(s) provided by the network operator, the customer shall use the most suitable antenna for that/those band(s)
Bandwidth	70 MHz in GSM850, 80 MHz in GSM900, 170 MHz in DCS & 140 MHz PCS band
Gain	1.4dBi @900 and 3dBi @1800 1.4dBi @850 and 3dBi @1900
Impedance	50•
Input power	> 2 W
VSWR absolute max	• 10:1 (limit to avoid permanent damage)
VSWR recommended	• 2:1 (limit to fulfil all regulatory requirements)

When using the GE865, since there's no antenna connector on the module, the antenna must be connected to the GE865 antenna pad (BGA Ball H5) by means of a transmission line implemented on the PCB.

In the case the antenna is not directly connected at the antenna pad of the GE865, then a PCB line is needed in order to connect with it or with its connector.







## 8 Logic level specifications

Where not specifically stated, all the interface circuits work at 2.8V CMOS logic levels. The following table shows the logic level specifications used in the GE865 interface circuits:

### Absolute Maximum Ratings -Not Functional

Parameter	Min	Max
Input level on any digital pin (CMOS 2.8) when on	-0.3V	+3.1V
Input level on any digital pin (CMOS 1.8) when on	-0.3V	+2.1V
Input voltage on analog pins when on	-0.3V	+3.0 V

### Operating Range - Interface levels (2.8V CMOS)

Level	Min	Max
Input high level	2.1V	3.1V
Input low level	0V	0.5V
Output high level	2.2V	3.1V
Output low level	0V	0.35V

For 1.8V signals:

### Operating Range - Interface levels (1.8V CMOS)

Level	Min	Max
Input high level	1.6V	2.0V
Input low level	0V	0.4V
Output high level	1,65V	2.0V
Output low level	0V	0.35V

### Current characteristics

Level	Typical
Output Current	1mA
Input Current	1uA



## 8.1 Reset signal

Signal	Function	I/O	Bga Ball
RESET#	Phone reset	I	C1

RESET# is used to reset the GE865 . Whenever this signal is pulled low, the GE865 is reset. When the device is reset it stops any operation. After the release of the reset GE865 is unconditionally shut down, without doing any detach operation from the network where it is registered. This behaviour is not a proper shut down because any GSM device is requested to issue a detach request on turn off. For this reason the Reset signal must not be used to normally shutting down the device, but only as an emergency exit in the rare case the device remains stuck waiting for some network response.

The RESET# is internally controlled on start-up to achieve always a proper power-on reset sequence, so there's no need to control this pin on start-up. It may only be used to reset a device already on that is not responding to any command.



### NOTE:

Do not use this signal to power off the GE865. Use the ON/OFF signal to perform this function or the AT#SHDN command.

### Reset Signal Operating levels:

Signal	Min	Max
RESET Input high	1.8V*	2.1V
RESET Input low	0V	0.2V

\* this signal is internally pulled up so the pin can be left floating if not used.

If unused, this signal may be left unconnected. If used, then it **must always be connected with an open collector transistor**, to permit to the internal circuitry the power on reset and under voltage lockout functions.



## 9 Serial Ports

The serial port on the GE865 is the core of the interface between the module and OEM hardware.

2 serial ports are available on the module:

- MODEM SERIAL PORT 1 (Main, ASC0)
- MODEM SERIAL PORT 2 (Auxiliary, ASC1)

### 9.1 MODEM SERIAL PORT

Several configurations can be designed for the serial port on the OEM hardware, but the most common are:

- RS232 PC com port
- microcontroller UART @ 2.8V - 3V (Universal Asynchronous Receive Transmit)
- microcontroller UART @ 5V or other voltages different from 2.8V

Depending from the type of serial port on the OEM hardware a level translator circuit may be needed to make the system work. The only configuration that doesn't need a level translation is the 2.8V UART.

The serial port on the GE865 is a +2.8V UART with all the 7 RS232 signals. It differs from the PC-RS232 in the signal polarity (RS232 is reversed) and levels. The levels for the GE865 UART are the CMOS levels:

#### Absolute Maximum Ratings -Not Functional

Parameter	Min	Max
Input level on any digital pad when on	-0.3V	+3.1V
Input voltage on analog pads when on	-0.3V	+3.1V

#### Operating Range - Interface levels (2.8V CMOS)

Level	Min	Max
Input high level $V_{IH}$	2.1V	3.1 V
Input low level $V_{IL}$	0V	0.5V
Output high level $V_{OH}$	2.2V	3.1V
Output low level $V_{OL}$	0V	0.35V



The signals of the GE865 serial port are:

RS232 Pin Number	Signal	GE865 Pad Number	Name	Usage
1	DCD - dcd_uart	B5	Data Carrier Detect	Output from the GE865 that indicates the carrier presence
2	RXD - tx_uart	A4	Transmit line *see Note	Output transmit line of GE865 UART
3	TXD - rx_uart	A3	Receive line *see Note	Input receive of the GE865 UART
4	DTR - dtr_uart	B3	Data Terminal Ready	Input to the GE865 that controls the DTE READY condition
5	GND	C2, C7, E5, E7, G1, G3, G4, G5, H3, H6	Ground	ground
6	DSR - dsr_uart	B2	Data Set Ready	Output from the GE865 that indicates the module is ready
7	RTS -rts_uart	A1	Request to Send	Input to the GE865 that controls the Hardware flow control
8	CTS - cts_uart	A2	Clear to Send	Output from the GE865 that controls the Hardware flow control
9	RI - ri_uart	B4	Ring Indicator	Output from the GE865 that indicates the incoming call condition



**NOTE:**

According to V.24, RX/TX signal names are referred to the application side, therefore on the GE865 side these signal are on the opposite direction: TXD on the application side will be connected to the receive line (here named TXD/ rx\_uart ) of the GE865 serial port and viceversa for RX.



**NOTE:**

For a minimum implementation, only the TXD and RXD lines can be connected, the other lines can be left open provided a software flow control is implemented.



**NOTE:**

In order to avoid a back powering effect it is recommended to avoid having any HIGH logic level signal applied to the digital pins of the GE865 when the module is powered off or during an ON/OFF transition.



## 9.2 RS232 level translation

In order to interface the GE865 with a PC com port or a RS232 (EIA/TIA-232) application a level translator is required. This level translator must:

- invert the electrical signal in both directions;
- change the level from 0/2.8V to +15/-15V .

Actually, the RS232 UART 16450, 16550, 16650 & 16750 chipsets accept signals with lower levels on the RS232 side (EIA/TIA-562), allowing a lower voltage-multiplying ratio on the level translator. Note that the negative signal voltage must be less than 0V and hence some sort of level translation is always required.

The simplest way to translate the levels and invert the signal is by using a single chip level translator. There are a multitude of them, differing in the number of drivers and receivers and in the levels (be sure to get a true RS232 level translator not a RS485 or other standards).

By convention the driver is the level translator from the 0-2.8V UART to the RS232 level. The receiver is the translator from the RS232 level to 0-2.8V UART.

In order to translate the whole set of control lines of the UART you will need:

- 5 drivers
- 3 receivers



### NOTE:

The digital input lines working at 2.8V CMOS have an absolute maximum input voltage of 3.0V; therefore the level translator IC shall not be powered by the +3.8V supply of the module. Instead, it must be powered from a +2.7V / +2.9V (dedicated) power supply.

This is because in this way the level translator IC outputs on the module side (i.e. GE865 inputs) will work at +3.8V interface levels, damaging the module inputs.

---



An example of level translation circuitry of this kind is:

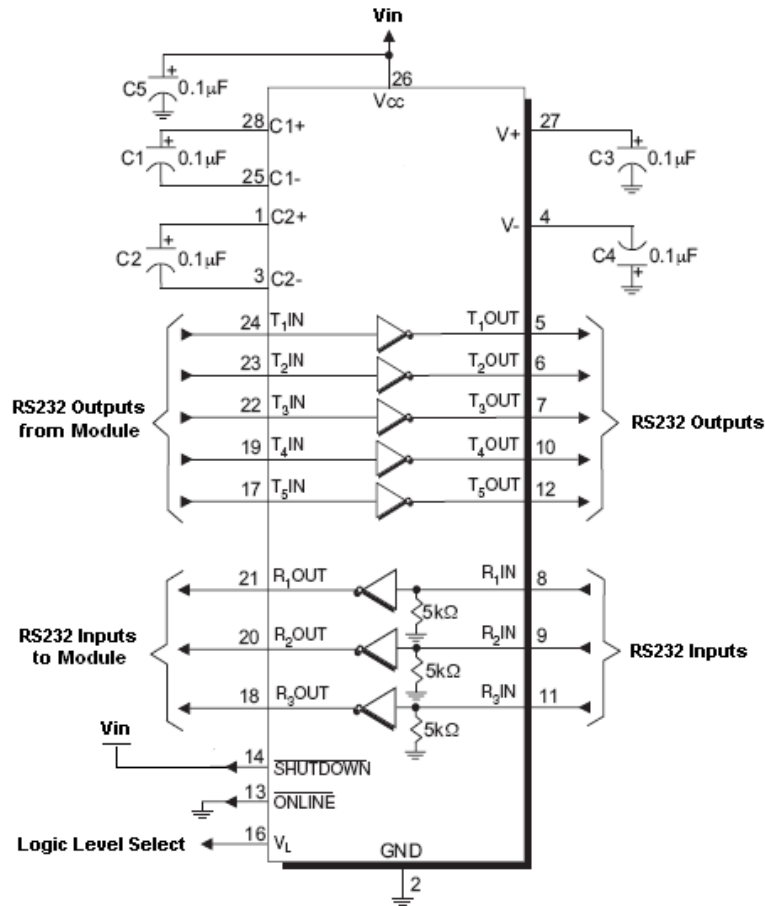

The example is done with a SIPEX SP3282EB RS232 Transceiver that could accept supply voltages lower than 3V DC.



**NOTE:**

In this case Vin has to be set with a value compatible with the logic levels of the module. (Max 2.9V DC). In this configuration the SP3282EB will adhere to EIA/TIA-562 voltage levels instead of RS232 (-5 ~ +5V).



Second solution could be done using a MAXIM transceiver (MAX218) In this case the compliance with RS232 (+-5V) is possible.

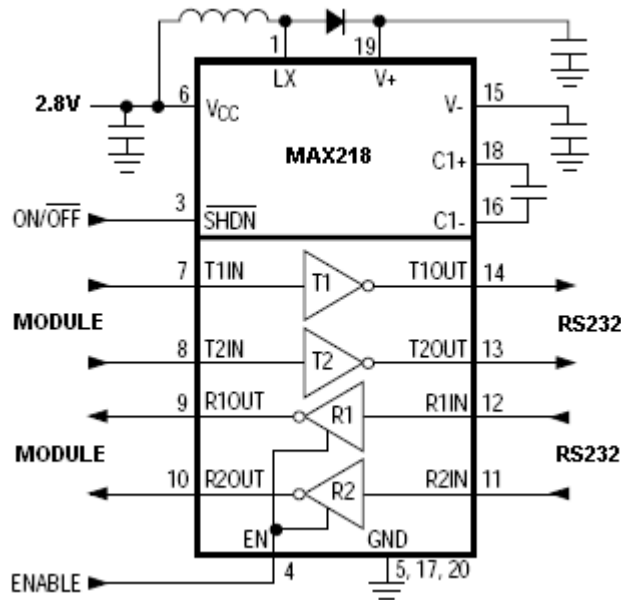

Another level adapting method could be done using a standard RS232 Transceiver (MAX3237EAI) adding some resistors to adapt the levels on the GE865 Input lines.

NOTE: In this case has to be taken in account the length of the lines on the application to avoid problems in case of High-speed rates on RS232.

The RS232 serial port lines are usually connected to a DB9 connector with the following layout:

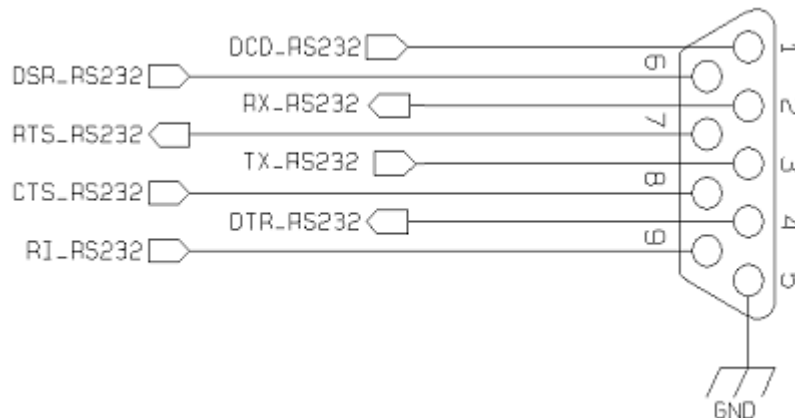

## 9.3 5V UART level translation

If the OEM application uses a microcontroller with a serial port (UART) that works at a voltage different from 2.8 - 3V, then a circuitry has to be provided to adapt the different levels of the two set of signals. As for the RS232 translation there are a multitude of single chip translators. For example a possible translator circuit for a 5V TRANSMITTER/RECEIVER can be:

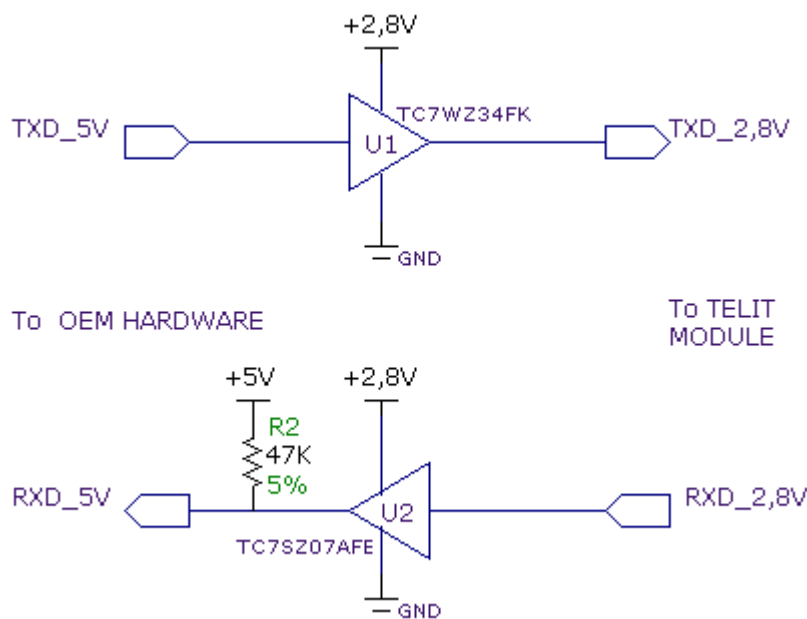

### TIP:

Note that the TC7SZ07AE has open drain output; therefore the resistor R2 is mandatory.



### NOTE:

The UART input line TXD (rx\_uart) of the GE865 is NOT internally pulled up with a resistor, so there may be the need to place an external 47K pull-up resistor, either the DTR (dtr\_uart) and RTS (rts\_uart) input lines are not pulled up internally, so an external pull-up resistor of 47K may be required.





---

**NOTE:**

The input lines working at 2.8VCMOS can be pulled-up with 47K

In case of reprogramming of the module has to be considered the use of the RESET line to start correctly the activity.

The preferable configuration is having an external supply for the buffer.

---



# 10 Audio Section Overview

The Base Band Chip of the GE865 provides one audio path both in Uplink (*transmit*) and in *Downlink* (*receive*) direction , as shown in the next figure .

For more information refer to Telit document :  
" 80000NT10007a Audio Settings Application Note " .

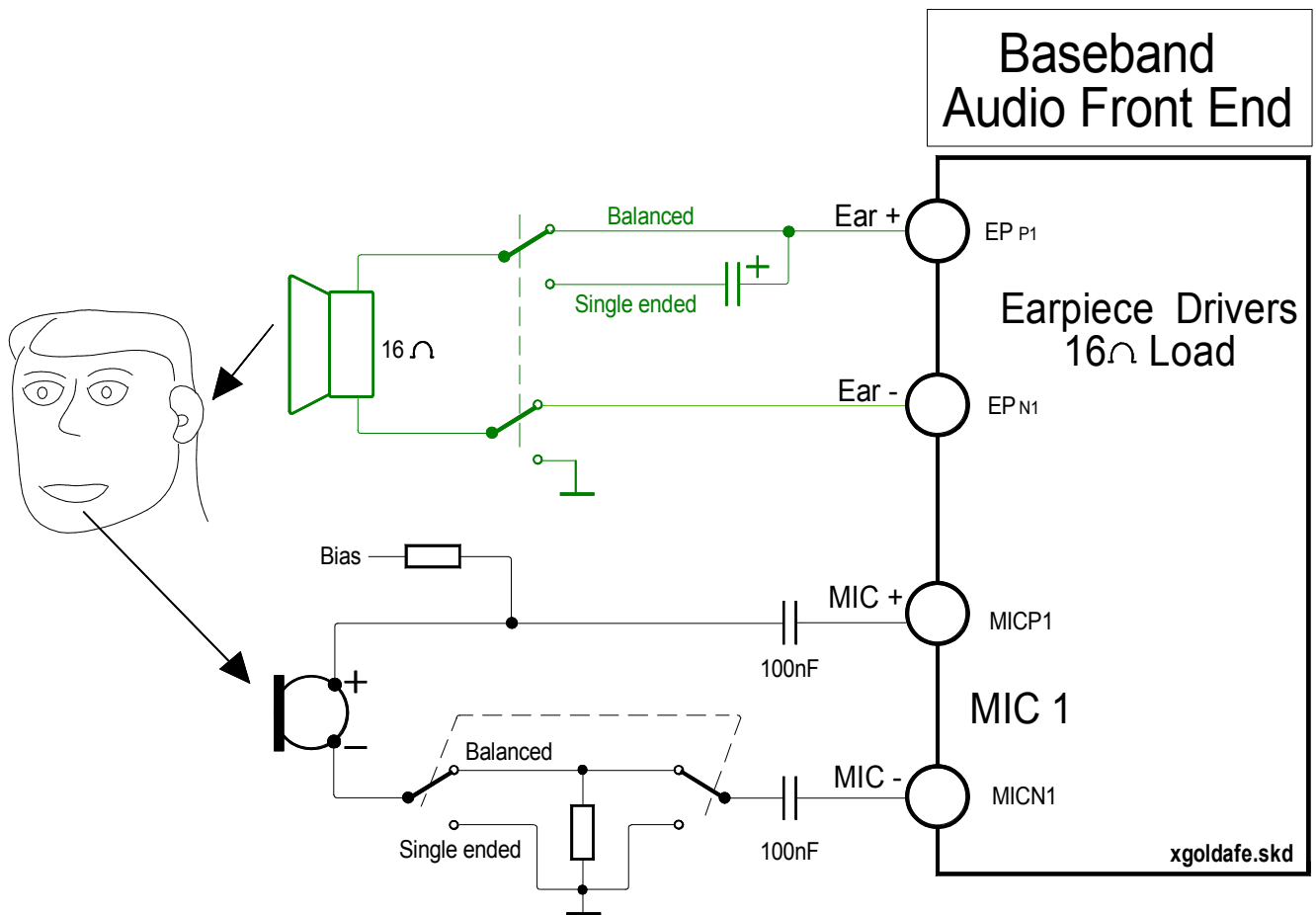

Audio Section Block Diagram



## 10.1 Electrical Characteristics



**TIP:** Being the microphone circuitry the more noise sensitive, its design and layout must be done with particular care. Both microphone paths are balanced and the OEM circuitry must be balanced designed to reduce the common mode noise typically generated on the ground plane. However the customer can use the unbalanced circuitry for particular application.

### 10.1.1 Input Lines

"MIC 1" differential microphone path	
Line Coupling	AC*
Line Type	Balanced
Coupling capacitor	• 100nF
Differential input resistance	50k
Differential input voltage	• 1,03V <sub>pp</sub> @ MicG=0dB



**(\*) WARNING :** AC means that the signals from the microphone have to be connected to input lines of the module through capacitors which value has to be • 100nF. Not respecting this constraint, the input stages will be damaged.



**WARNING:** when particular OEM application needs a *Single Ended Input* configuration, it is forbidden connecting the unused input directly to Ground, but only through a capacitor which value has to be • 100nF.. Don't forget that in Single Ended configuration the useful input signal will be halved.



## 10.1.2 Output Lines



**TIP :** We suggest driving the load differentially , thus the output swing will double and the need for the big output coupling capacitor avoided. However if particular OEM application needs, also a Single Ended (*S.E*) circuitry can be implemented but the output power will be reduced four times.

The OEM circuitry shall be designed to reduce the common mode noise typically generated on the ground plane, getting the maximum power output from the device (low resistance tracks).



**WARNING.** When in *Single Ended* configuration, the unused output line must be left open: if this constraint is not respected, the output stage will be damaged.

"EAR_MT" Output Lines		
line coupling	single-ended differential	AC DC
output load resistance		• 14
internal output resistance		4 (typical)
signal bandwidth		150 ÷ 4000 Hz @ -3dB
max. differential output voltage		1.31 V <sub>rms</sub> (typical, open circuit)
differential output voltage		328mV <sub>rms</sub> /16 @ -12dBFS (*)
volume increment		2 dB per step
volume steps		10

(\*) *0dBFS* is the *normalized* overall Analog Gain equal to  $3,7V_{pp}$  differential



# 11 General Purpose I/O

The general purpose I/O pads can be configured to act in three different ways:

- input
- output
- alternate function (*internally controlled*)

*Input pads* can only be read ; they report the digital value (*high or low*) present on the pad at the read time .

*Output pads* can only be written or queried and set the value of the pad output.

An *alternate function pad* is internally controlled by the GE865 firmware and acts depending on the function implemented.

For Logic levels please refer to chapter 8.

The following table shows the available GPIO on the GE865 .

Signal	I/O	Function	Type	Input / output current	Default State	ON_OFF state	State during Reset	Note
GPIO_01	I/O	GPIO01 Configurable GPIO	CMOS 2.8V	1uA/1mA	INPUT	0	0	
GPIO_02	I/O	GPIO02 Configurable GPIO	CMOS 2.8V	1uA/1mA	INPUT	0	0	Alternate function (JDR)
GPIO_03	I/O	GPIO03 Configurable GPIO	CMOS 2.8V	1uA/1mA	INPUT	0	0	
GPIO_04	I/O	GPIO04 Configurable GPIO	CMOS 2.8V	1uA/1mA	INPUT	0	0	Alternate function (RF Transmission Control)
GPIO_05	I/O	GPIO05 Configurable GPIO	CMOS 2.8V	1uA/1mA	INPUT	0	0	Alternate function (RFTXMON)
GPIO_06	I/O	GPIO06 Configurable GPIO	CMOS 2.8V	1uA/1mA	INPUT	0	0	Alternate function (ALARM)
GPIO_07	I/O	GPIO07 Configurable GPIO	CMOS 2.8V	1uA/1mA	INPUT	0	0	Alternate function (BUZZER)
GPIO_08	I/O	GPIO08 Configurable GPIO	CMOS 2.8V	1uA/1mA	INPUT	0	0	
GPIO_09	I/O	GPIO09 Configurable GPIO	CMOS 2.8V		1	1	1	Open Drain
GPIO_10	I/O	GPIO10 Configurable GPIO	CMOS 2.8V		1	1	1	Open Drain

Not all GPIO pads support all these three modes:

- GPIO2 supports all three modes and can be input, output, Jamming Detect Output (Alternate function)
- GPIO4 supports all three modes and can be input, output, RF Transmission Control (Alternate function)



- GPIO5 supports all three modes and can be input, output, RFTX monitor output (Alternate function)
- GPIO6 supports all three modes and can be input, output, alarm output (Alternate function)
- GPIO7 supports all three modes and can be input, output, buzzer output (Alternate function)

## 11.1 GPIO Logic levels

Where not specifically stated, all the interface circuits work at 2.8V CMOS logic levels. The following table shows the logic level specifications used in the GE865 interface circuits:

### Absolute Maximum Ratings -Not Functional

Parameter	Min	Max
Input level on any digital pin when on (CMOS 2.8)	-0.3V	+3.1V
Input level on any digital pin when on (CMOS 1.8)	-0.3V	+2.1V
Input voltage on analog pins when on	-0.3V	+3.0V

### Operating Range - Interface levels (2.8V CMOS)

Level	Min	Max
Input high level	2.1V	3.1V
Input low level	0V	0.5V
Output high level	2.2V	3.1V
Output low level	0V	0.35V

For 1.8V signals:

### Operating Range - Interface levels (1.8V CMOS)

Level	Min	Max
Input high level	1.6V	2.0V
Input low level	0V	0.4V
Output high level	1,65V	1.85V
Output low level	0V	0.35V



## 11.2 Using a GPIO Pad as INPUT

The GPIO pads, when used as inputs, can be connected to a digital output of another device and report its status, provided this device has interface levels compatible with the 2.8V CMOS levels of the GPIO.

If the digital output of the device to be connected with the GPIO input pad has interface levels different from the 2.8V CMOS, then it can be buffered with an open collector transistor with a 47K pull up to 2.8V.



---

**NOTE:**

In order to avoid a back powering effect it is recommended to avoid having any HIGH logic level signal applied to the digital pins of the GE865 when the module is powered off or during an ON/OFF transition.

---

## 11.3 Using a GPIO Pad as OUTPUT

The GPIO pads, when used as outputs, can drive 2.8V CMOS digital devices or compatible hardware. When set as outputs, the pads have a push-pull output and therefore the pull-up resistor may be omitted.

## 11.4 Using the RF Transmission Control GPIO4

The GPIO4 pin, when configured as RF Transmission Control Input, permits to disable the Transmitter when the GPIO is set to Low by the application.

In the design is necessary to add a pull up resistor (47K to 2.8V);



## 11.5 Using the RFTXMON Output GPIO5

The GPIO5 pin, when configured as RFTXMON Output, is controlled by the GE865 module and will rise when the transmitter is active and fall after the transmitter activity is completed.

There are 2 different modes for this function:

1) Active during all the calls:

For example, if a call is started, the line will be HIGH during all the conversation and it will be again LOW after hanged up.

The line rises up 300ms before first TX burst and will became again LOW from 500ms to 1s after last TX burst.

2) Active during all the TX activity:

The GPIO is following the TX bursts

Please refer to the AT User interface manual for additional information on how to enable this function.

## 11.6 Using the Alarm Output GPIO6

The GPIO6 pad, when configured as Alarm Output, is controlled by the GE865 module and will rise when the alarm starts and fall after the issue of a dedicated AT command. This output can be used to power up the GE865 controlling microcontroller or application at the alarm time, giving you the possibility to program a timely system wake-up to achieve some periodic actions and completely turn off either the application and the GE865 during sleep periods, dramatically reducing the sleep consumption to few  $\mu$ A.

In battery-powered devices this feature will greatly improve the autonomy of the device.



## 11.7 Using the Buzzer Output GPIO7

The GPIO7 pad, when configured as Buzzer Output, is controlled by the GE865 module and will drive a Buzzer driver with appropriate square waves.

This permits to your application to easily implement Buzzer feature with ringing tones or melody played at the call incoming, tone playing on SMS incoming or simply playing a tone or melody when needed.

A sample interface scheme is included below to give you an idea of how to interface a Buzzer to the GPIO7:

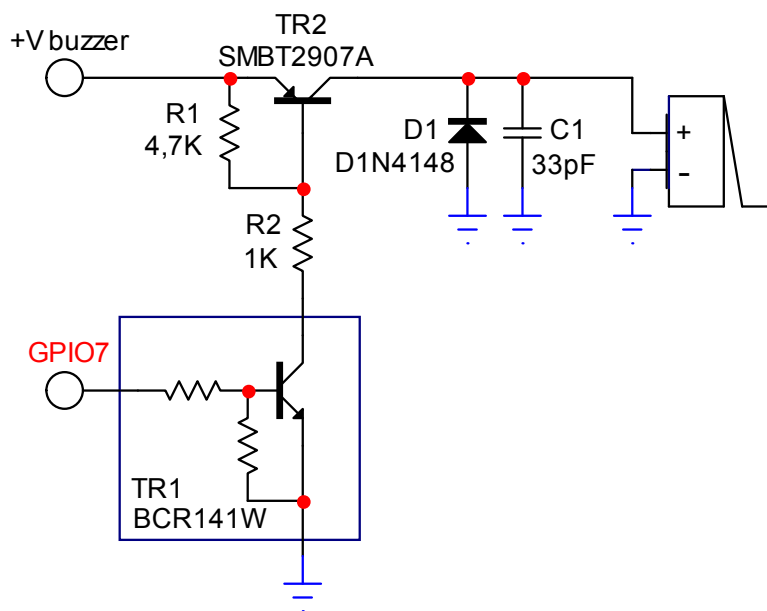

### NOTE:

To correctly drive a buzzer a driver must be provided, its characteristics depend on the Buzzer and for them refer to your buzzer vendor.



## 11.8 Magnetic Buzzer Concepts

### 11.8.1 Short Description

A magnetic Buzzer is a sound-generating device with a coil located in the magnetic circuit consisting of a permanent magnet, an iron core, a high permeable metal disk and a vibrating diaphragm.

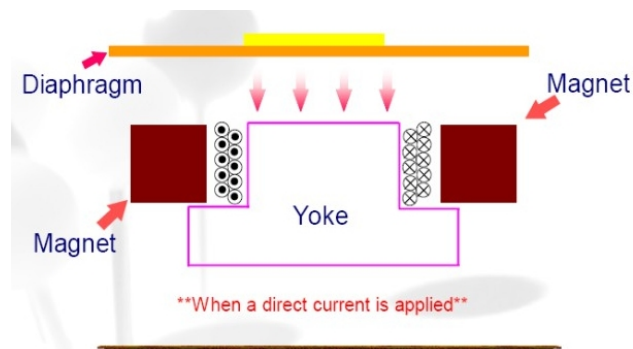

Drawing of the Magnetic Buzzer.

The disk and diaphragm are attracted to the core by the magnetic field. When an oscillating signal is moved through the coil, it produces a fluctuating magnetic field which vibrates the diaphragm at a frequency of the drive signal. Thus the sound is produced relative to the frequency applied.

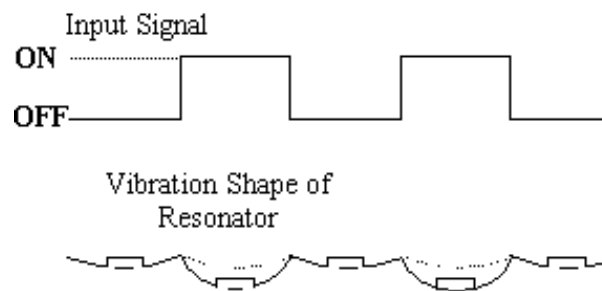

Diaphragm movement.



## 11.8.2 Frequency Behaviour

The frequency behaviour represents the effectiveness of the reproduction of the applied signals. Because performance is related to a square driving waveform (whose amplitude varies from 0V to  $V_{pp}$ ), if you modify the waveform (e.g. *from square to sinus*) the frequency response will change.

## 11.8.3 Power Supply Influence

Applying a signal whose amplitude is different from that suggested by the manufacturer, the performance change following the rule “if resonance frequency  $f_o$  increases, amplitude decreases”.

Because resonance frequency depends on acoustic design, by lowering the amplitude of the driving signal the response bandwidth tends to become narrow, and vice versa.

Summarizing:  $V_{pp} \bullet \rightarrow f_o \bullet$        $V_{pp} \bullet \rightarrow f_o \bullet$

The risk is that the  $f_o$  could easily fall outside of new bandwidth; consequently the SPL could be much lower than the expected.



### WARNING:

It is very important to respect the sense of the applied voltage: never apply to the “-” pin a voltage more positive than the “+” pin: if this happens, the diaphragm vibrates in the opposite direction with a high probability to be expelled from its physical position. This damages the device permanently.

## 11.8.4 Working Current Influence

In the component data sheet you will find the value of MAX CURRENT: this represents the maximum average current that can flow at nominal voltage without current limitation. In other words it is not the peak current, which could be twice or three times higher. If driving circuitry does not support these peak values, the SPL will never reach the declared level or the oscillations will stop.



## 11.9 Indication of network service availability

The STAT\_LED pin status shows information on the network service availability and Call status.

In the GE865 modules, the STAT\_LED usually needs an external transistor to drive an external LED.

Therefore, the status indicated in the following table is reversed with respect to the pin status.

LED status	Device Status
Permanently off	Device off
Fast blinking (Period 1s, Ton 0,5s)	Net search / Not registered / turning off
Slow blinking (Period 3s, Ton 0,3s)	Registered full service
Permanently on	a call is active

A schematic example could be:

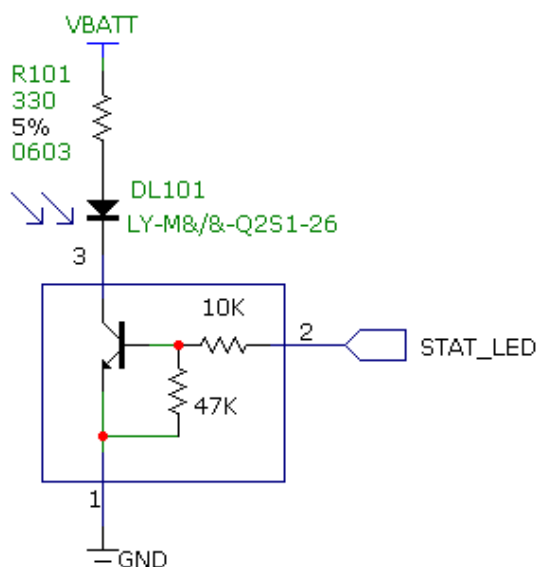

## 11.10 RTC Bypass out

The VRTC pin brings out the Real Time Clock supply, which is separate from the rest of the digital part, allowing having only RTC going on when all the other parts of the device are off.

To this power output a backup capacitor can be added in order to increase the RTC autonomy during power off of the battery. NO Devices must be powered from this pin.

## 11.11 External SIM Holder Implementation

Please refer to the related User Guide (SIM Holder Design Guides, 80000NT10001a).



# 12 DAC and ADC section

## 12.1 DAC Converter

### 12.1.1 Description

The GE865 provides a Digital to Analog Converter. The signal (named DAC\_OUT) is available on BGA Ball G7 of the GE865 and on pin 17 of PL102 on GE865 Interface Board (CS1324).

The on board DAC is a 10 bit converter, able to generate a analogue value based a specific input in the range from 0 up to 1023. However, an external low-pass filter is necessary

	Min	Max	Units
Voltage range (filtered)	0	2,6	Volt
Range	0	1023	Steps

The precision is 10 bits so, if we consider that the maximum voltage is 2V, the integrated voltage could be calculated with the following formula:

$$\textit{Integrated output voltage} = (2 * \textit{value}) / 1023$$

DAC\_OUT line must be integrated (for example with a low band pass filter) in order to obtain an analog voltage.



## 12.1.2 Enabling DAC

An *AT command* is available to use the DAC function.  
The command is: **AT#DAC=** [*<enable>* [, *<value>*]]

*<value>* - scale factor of the integrated output voltage (0..1023 - 10 bit precision)  
it must be present if *<enable>*=1

Refer to SW User Guide or AT Commands Reference Guide for the full description of this function.



### NOTE:

The DAC frequency is selected internally. D/A converter must not be used during POWERSAVING.

## 12.1.3 Low Pass Filter Example

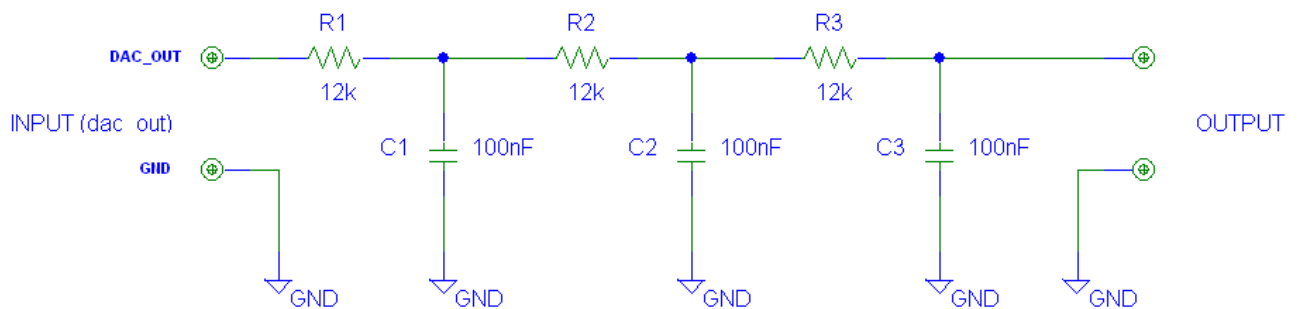

## 12.2 ADC Converter

### 12.2.1 Description

The on board A/D are 11-bit converter. They are able to read a voltage level in the range of 0÷2 volts applied on the ADC pin input, store and convert it into 11 bit word.

	Min	Max	Units
Input Voltage range	0	2	Volt
AD conversion	-	11	bits
Resolution	-	< 1	mV

The GE865 module provides 2 Analog to Digital Converters.  
The input lines are:

#### **ADC\_IN1**

available on Ball **F5** and Pin 19 of PL102 on GE865 Interface Board *(CS1324)*.

#### **ADC\_IN2**

available on Ball **F6** and Pin 20 of PL102 on GE865 Interface Board *(CS1324)*.

### 12.2.2 Using ADC Converter

An AT command is available to use the ADC function.

The command is *AT#ADC=1,2*

The read value is expressed in mV

Refer to SW User Guide or AT Commands Reference Guide for the full description of this function.



# 13 Mounting the GE865 on your Board

## 13.1 General

The GE865 modules have been designed in order to be compliant with a standard lead-free SMT process.

## 13.2 Module finishing & dimensions

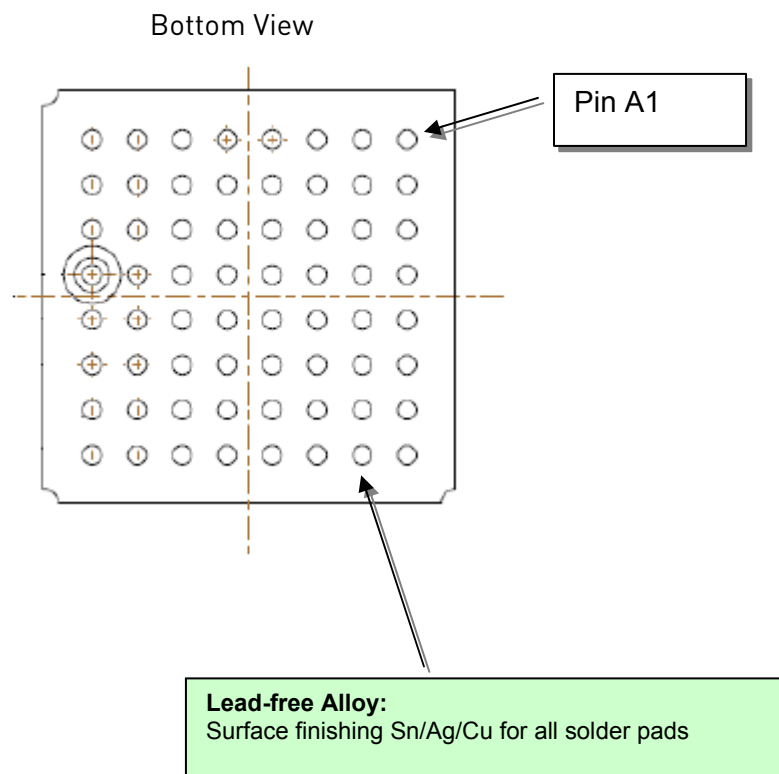

### 13.3 Recommended foot print for the application

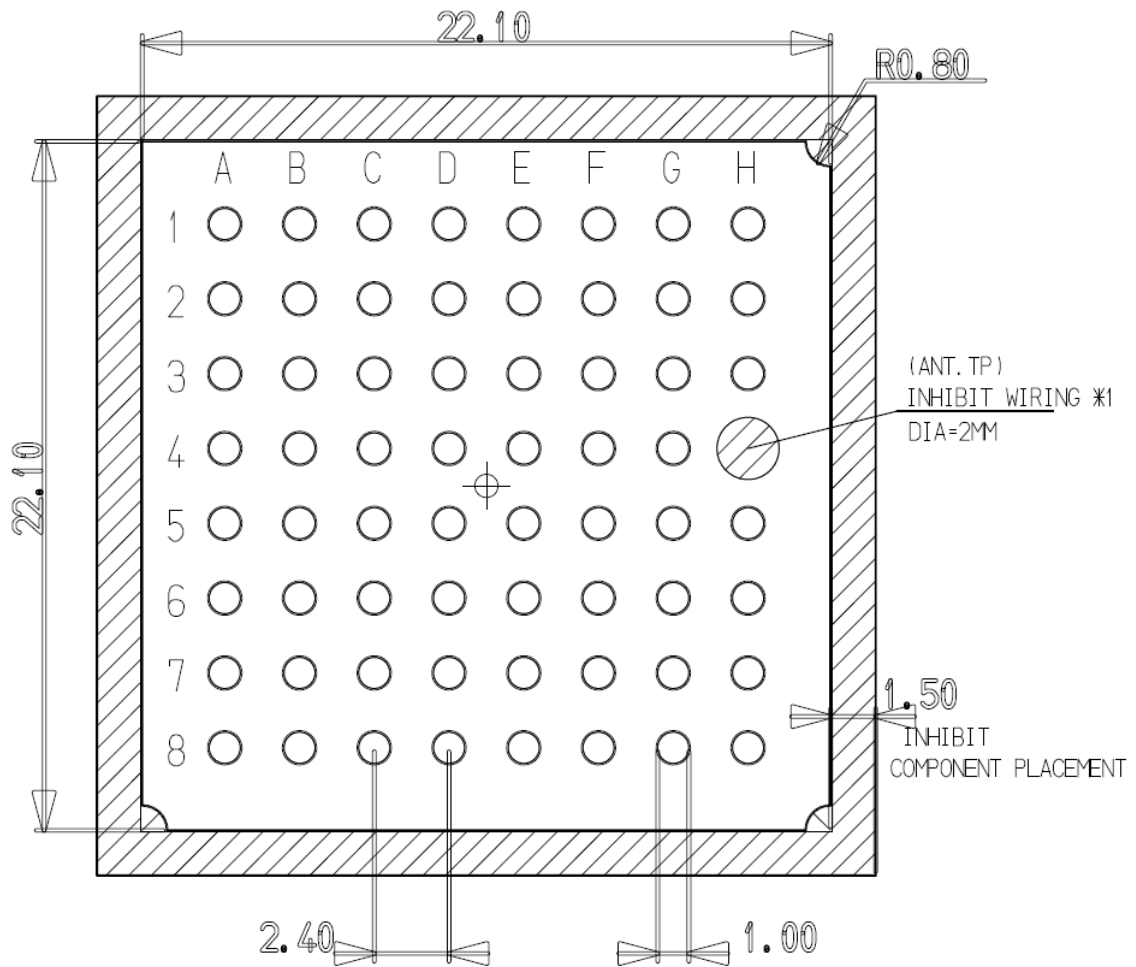

In order to easily rework the GE865 is suggested to consider on the application a 1.5mm Inhibit area around the module.

It is also suggested, as common rule for an SMT component, to avoid having a mechanical part of the application in direct contact with the module.



**NOTE:** In the customer application, the region under INHIBIT WIRING \*1 (see figure) must be clear from signal or ground paths.



## 13.4 Debug of the GE865 in production

To test and debug the mounting of the GE865, we strongly recommend to foreseen test pads on the host PCB, in order to check the connection between the GE865 itself and the application and to test the performance of the module connecting it with an external computer. Depending by the customer application, these pads include, but are not limited to the following signals:

- TXD
- RXD
- ON/OFF
- RESET
- GND
- VBATT
- TX\_AUX
- RX\_AUX
- PWRMON
- SERVICE

## 13.5 Stencil

Stencil's apertures layout can be the same of the recommended footprint (1:1), we suggest a thickness of stencil foil  $\geq 120\mu\text{m}$ .



## 13.6 PCB pad design

Non solder mask defined” (NSMD) type is recommended for the solder pads on the PCB.

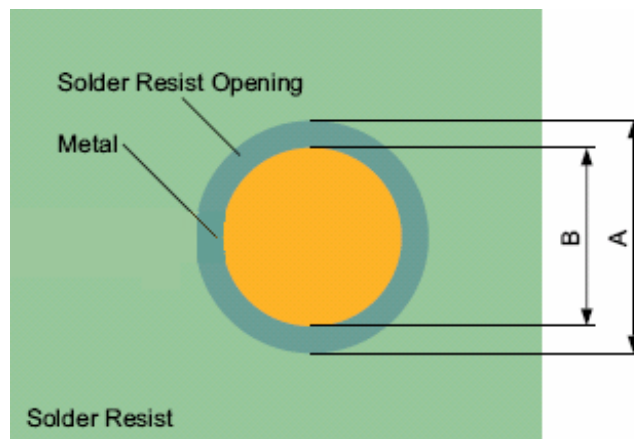
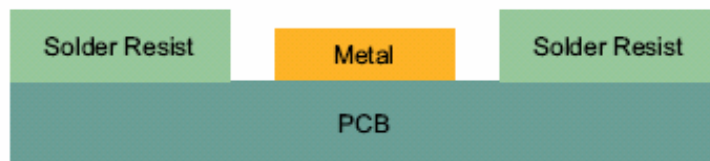

Recommendations for PCB pad dimensions

Ball pitch [mm]	2,4
Solder resist opening diameter A [mm]	1,150
Metal pad diameter B [mm]	1 ± 0.05









**NOTE:** All temperatures refer to topside of the package, measured on the package body surface

---



---

**WARNING:** The GE865 module withstands one reflow process only.

---



# 14 Packing system

## 14.1 Packing on tray

The GE865 modules are packaged on trays of **50** pieces each. This is especially suitable for the GE865 according to SMT processes for pick & place movement requirements. See detail B for module positioning and tray orientation into the envelope.

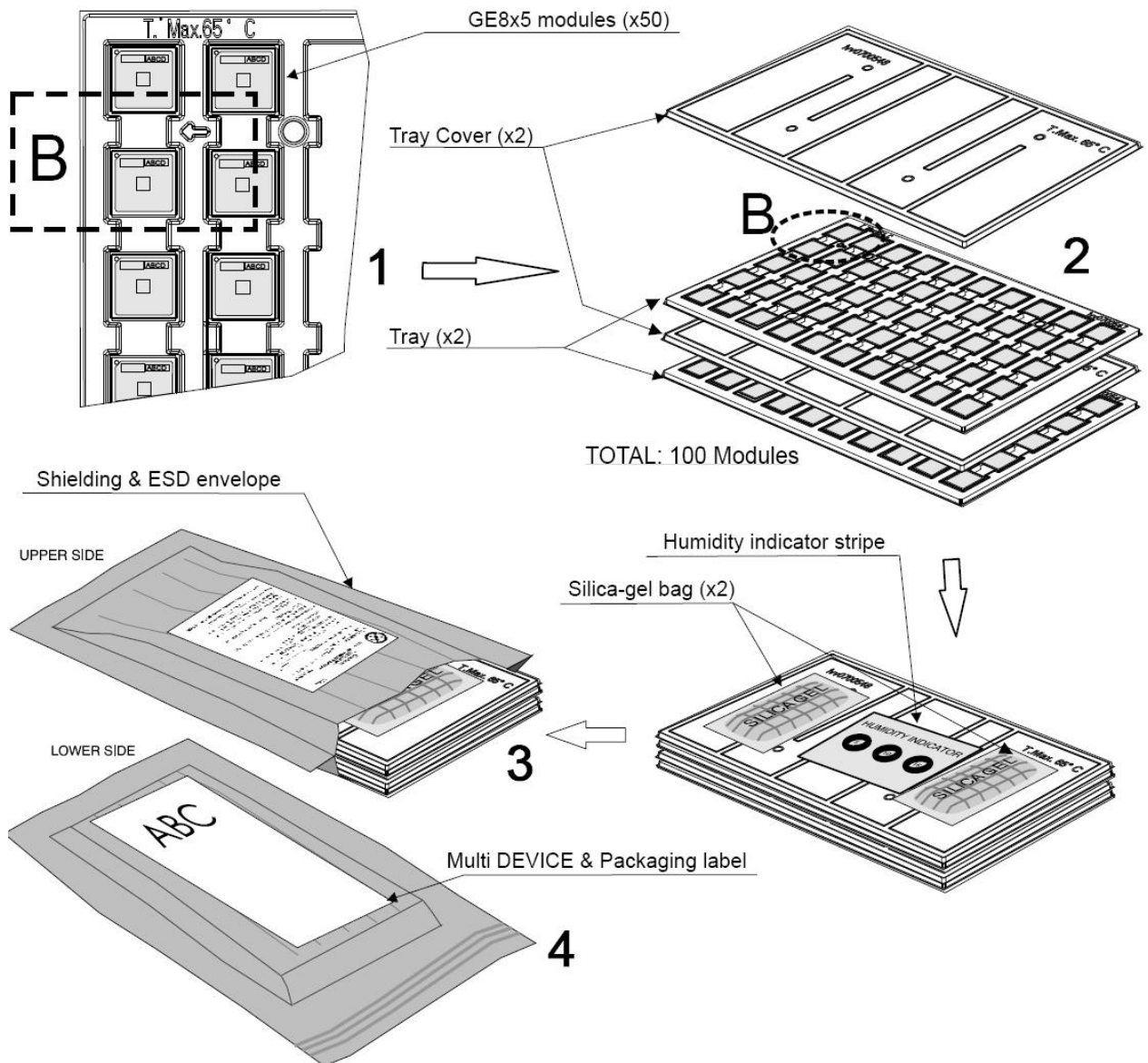

### 14.1.1 Tray detail

The size of the tray is: 329 x 176mm.

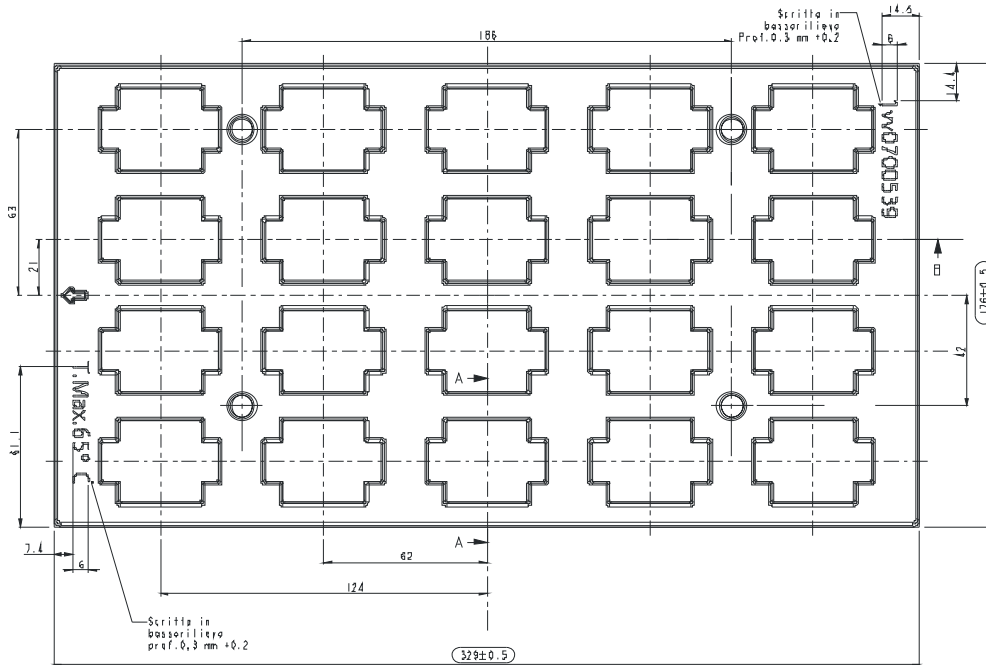

**Section A-A**

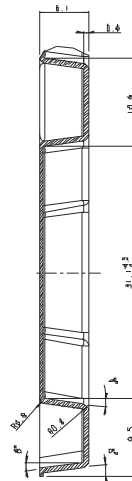

**WARNING:** These trays can withstand at the maximum temperature of 65° C.



## 14.2 Packaging on reel

The GE865-QUAD can be packaged on reels of **200** pieces each. See figure for module positioning into the carrier.

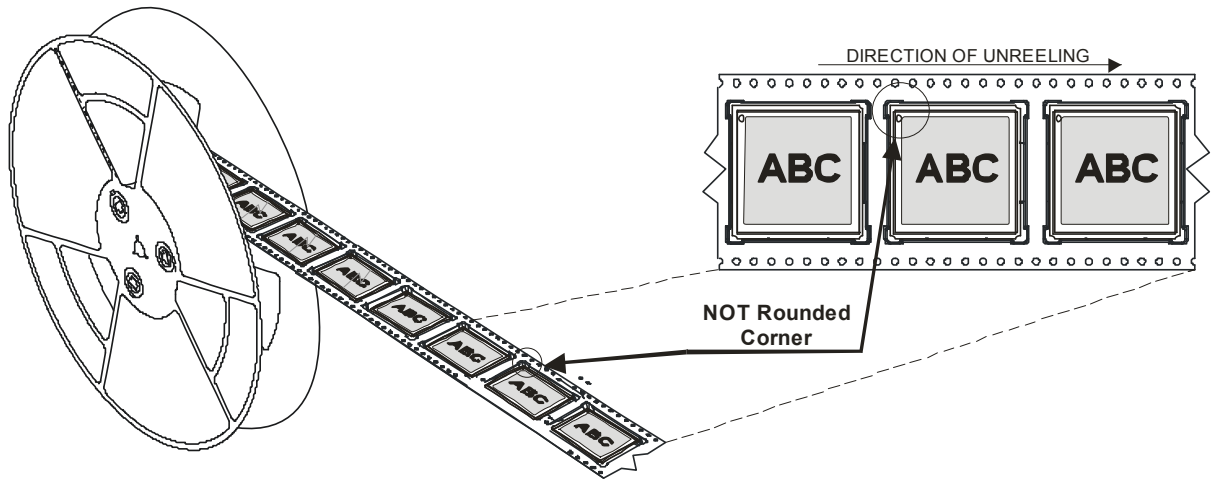

### 14.2.1 Carrier Tape detail

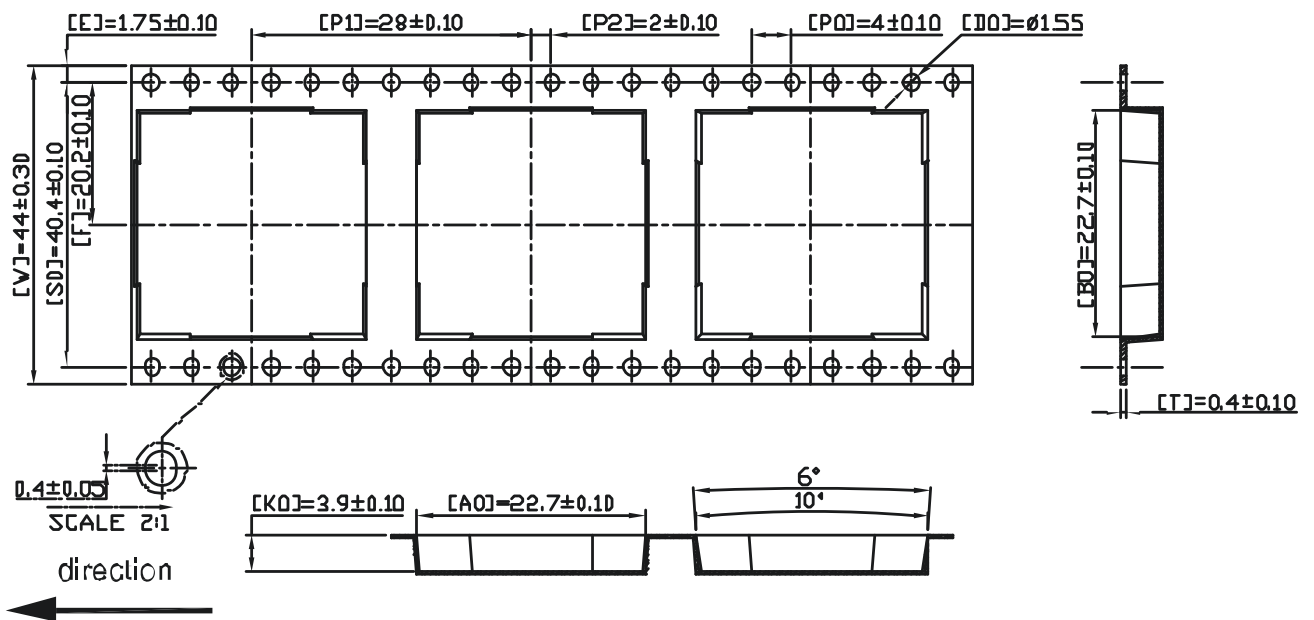

### 14.2.2 Reel detail

