

GC864-QUAD-C9 Audio User Guide

1VV0300850 - Rev.0 2009-07-20



2. Generality



NOTE:

The GC864-QUAD-C9 provides the same characteristics of the GE864-QUAD, as far as Quad-Band EGSM 850/900/1800/1900Mhz GSM and GPRS Class 10 technologies support and over the air firmware update by means of Premium FOTA Management.

For further integration details (e.g. SIM Card Connectivity details, Hardware Commands, Audio Settings , etc.) that may not be explained in this document, refer to the Telit documentation as specified in the related documents list (paragraph [1.5](#)).



3. ZIF Connector

3.1. Reference Position

Figure 1 shows the position of pin 1 and pin 40 on the ZIF connector.



Figure 1

3.2. Useful audio signals

Only the pins related to the audio section are highlighted (bold letters) in the table.

| Pin Number | Function | In/Out | Pin Number | Function | In/Out |
|------------|---------------|---------------|------------|----------------|----------------------|
| 1 | VBATT | Power | 21 | RTS | In |
| 2 | VBATT | Power | 22 | DTR | In |
| 3 | VBATT | Power | 23 | DCD | Out |
| 4 | VBATT | Power | 24 | SIM_IN | In |
| 5 | VBATT | Power | 25 | SIM-RST | Out |
| 6 | GND | Ground | 26 | SIM-IO | In/Out |
| 7 | GND | Ground | 27 | SIM-CLK | Out |
| 8 | GND | Ground | 28 | SIM-VCC | Out |
| 9 | GND | Ground | 29 | GND | Ground |
| 10 | GND | Ground | 30 | VRTC | In |
| 11 | Not Connected | Not Connected | 31 | RESET | Input |
| 12 | Not Connected | Not Connected | 32 | STAT-LED | Out |
| 13 | Vaux | Out | 33 | EAR_MT+ | Analog Output |
| 14 | Not Connected | Not connected | 34 | EAR_MT- | Analog Output |
| 15 | ON_OFF | In | 35 | EAR_HF+ | Analog Output |
| 16 | DSR | Out | 36 | EAR_HF- | Analog Output |
| 17 | RI | Out | 37 | MIC_MT+ | Analog Input |
| 18 | RXD | Out | 38 | MIC_MT- | Analog Input |
| 19 | TXD | In | 39 | MIC_HF+ | Analog Input |
| 20 | CTS | Out | 40 | MIC_HF- | Analog Input |

Table 1 . Pin-out configuration



Moreover the SIDETONE functionality could be enabled at request in both modes, enabling and setting by proper AT Commands the amplifier fitted between the transmit and the receive path.

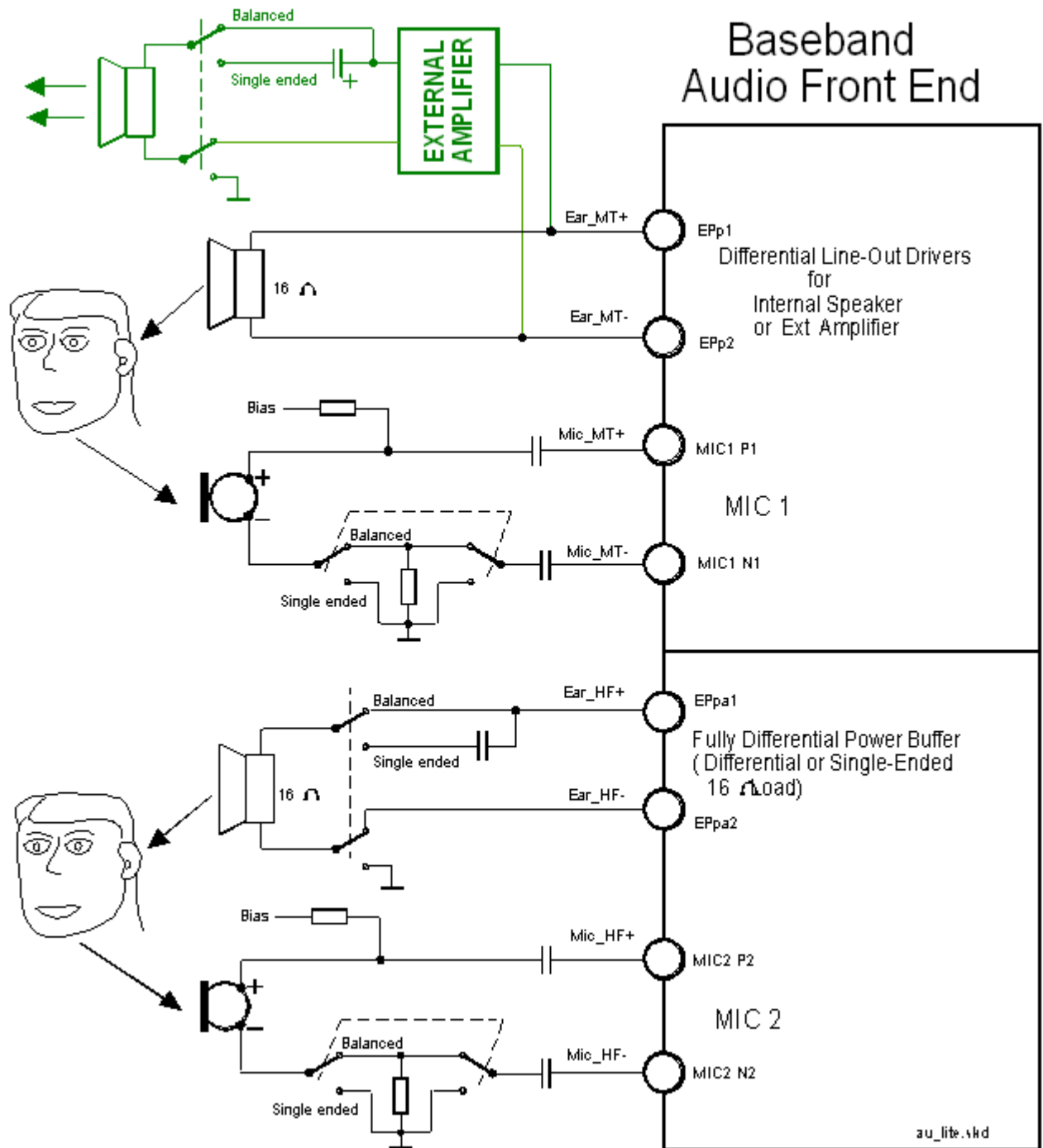

Figure 2 . Audio Section Block Diagram



4.2. Electrical Characteristics



TIP: Being the microphone circuitry the more noise sensitive, its design and layout must be done with particular care. Both microphone paths are balanced and the OEM circuitry must be balanced designed to reduce the common mode noise typically generated on the ground plane. However the customer can use the unbalanced (Single Ended) circuitry for particular application.

4.2.1. Input Lines

| "MIC_MT" and "MIC_HF" differential microphone paths | |
|---|--|
| Line Coupling | AC* |
| Line Type | Balanced |
| Coupling capacitor | $\geq 100\text{nF}$ |
| Differential input resistance | $50\text{k}\Omega$ |
| Differential input voltage | $\leq 1,03\text{V}_{\text{pp}}$ @ $\text{MicG}=0\text{dB}$ |
| volume increment | 6 dB/step |
| volume steps | 7 |



(*) WARNING:

AC* means that the signals from the microphone have to be connected to input lines of the module through capacitors which value has to be $\geq 100\text{nF}$.
Not respecting this constraint, the input stages will be damaged.

WARNING:

when particular OEM application needs a *Single Ended Input* configuration, it is forbidden connecting the unused input directly to Ground, but only through a 100nF capacitor.
Don't forget that in Single Ended configuration the useful input signal will be halved.



5. GC864-QUAD-C9 Schematic diagram

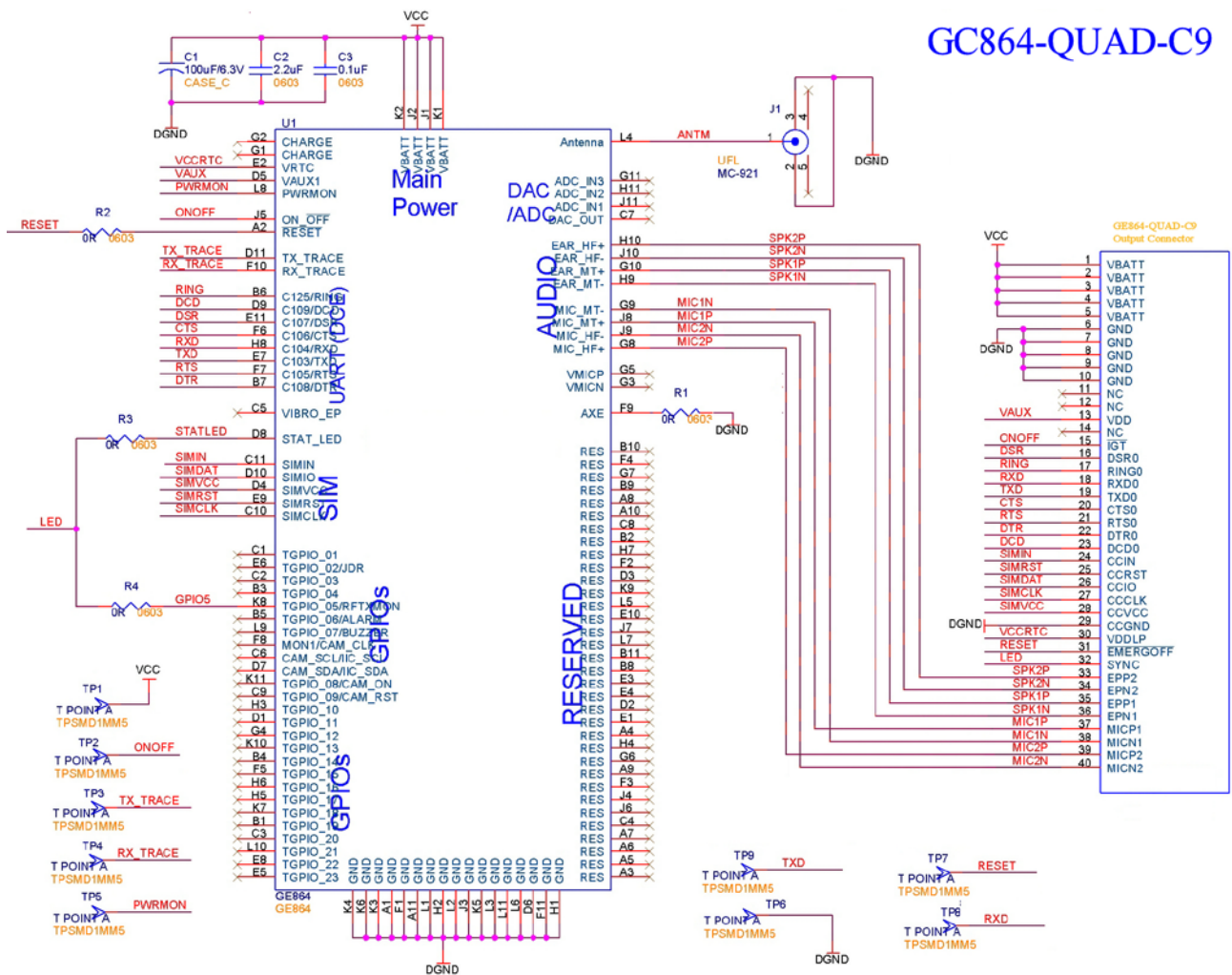

6. GC864-QUAD-C9 versus MC35i

6.1. UPLINK electrical characteristics

| | GC864-QUAD-C9 | | | MC35i | | |
|-----------------------|-------------------------------|--------|------|-----------------------------|-------|------|
| | MIC_MT | MIC_HF | Note | MIC_1 | MIC_2 | Note |
| Line Coupling | AC | | | DC | | |
| Line Type | Balanced | | | Balanced | | |
| Coupling capacitor | Mandatory $\geq 100\text{nF}$ | | | With “no biased” microphone | | |
| Bias network | external | | | internal | | |
| Differential R_{in} | 50k Ω | | | 2k Ω | | |
| Differential V_{in} | $\leq 1,03V_{pp}$ | | | $\leq 1,03V_{pp}$ | | |
| Volume Range | (0 ÷ +42)dB | | | (0 ÷ +42)dB | | |
| | +/- 6dB | | | - ∞ ÷ 0dB | | |
| Volume Increment | 6dB/step | | | 6dB/step | | |
| | 1dB/step | | | continuous | | |
| Unused pins | Grounded through 100nF | | | open | | |



