

Disclaimer

The information contained in this document is the proprietary information of Telit Communications S.p.A. and its affiliates ("TELIT").

The contents are confidential and any disclosure to persons other than the officers, employees, agents or subcontractors of the owner or licensee of this document, without the prior written consent of Telit, is strictly prohibited.

Telit makes every effort to ensure the quality of the information it makes available. Notwithstanding the foregoing, Telit does not make any warranty as to the information contained herein, and does not accept any liability for any injury, loss or damage of any kind incurred by use of or reliance upon the information.

Telit disclaims any and all responsibility for the application of the devices characterized in this document, and notes that the application of the device must comply with the safety standards of the applicable country, and where applicable, with the relevant wiring rules.

Telit reserves the right to make modifications, additions and deletions to this document due to typographical errors, inaccurate information, or improvements to programs and/or equipment at any time and without notice.

Such changes will, nevertheless be incorporated into new editions of this document.

Copyright: Transmittal, reproduction, dissemination and/or editing of this document as well as utilization of its contents and communication thereof to others without express authorization are prohibited. Offenders will be held liable for payment of damages. All rights are reserved.

Copyright © Telit Communications S.p.A. 2010.



Contents

1. Introduction	5
1.1. Scope.....	5
1.2. Audience.....	5
1.3. Contact Information, Support	5
1.4. Document Organization	6
1.5. Text Conventions.....	6
1.6. Related Documents	6
1.7. Document History	6
2. Battery charger design	7
2.1. Example of battery chargers	7
2.1.1. Battery Charger with 5V input.....	7
2.1.2. Battery Charger with up to 76V input.....	8



1.4. Document Organization

This document contains the following chapters (sample):

[“Chapter 1: “Introduction”](#) provides a scope for this document, target audience, contact and support information, and text conventions.

[“Chapter 2: “Chapter two”](#) gives guideline about how to design a battery charger.

1.5. Text Conventions



Danger – This information MUST be followed or catastrophic equipment failure or bodily injury may occur.



Caution or Warning – Alerts the user to important points about integrating the module, if these points are not followed, the module and end user equipment may fail or malfunction.



Tip or Information – Provides advice and suggestions that may be useful when integrating the module.

All dates are in ISO 8601 format, i.e. YYYY-MM-DD.

1.6. Related Documents

- Hardware User Guide of the relevant Telit module
- AT Command User Guide, 80000ST10025a
- Telit modules SW User Guide, 1w0300784

1.7. Document History

Revision	Date	Changes
0	2010-08-27	First issue
1	2010-10-04	Added GL865-DUAL to the applicability table



2. Battery charger design

The products listed in the applicability table are not equipped with a battery charger. Aim of this application note therefore, is to help the customers to design a battery charger that goes along with a Telit module, suitable for applications that are battery powered with a Li-Ion (or Li-Polymer) cell.

2.1. Example of battery chargers

2.1.1. Battery Charger with 5V input

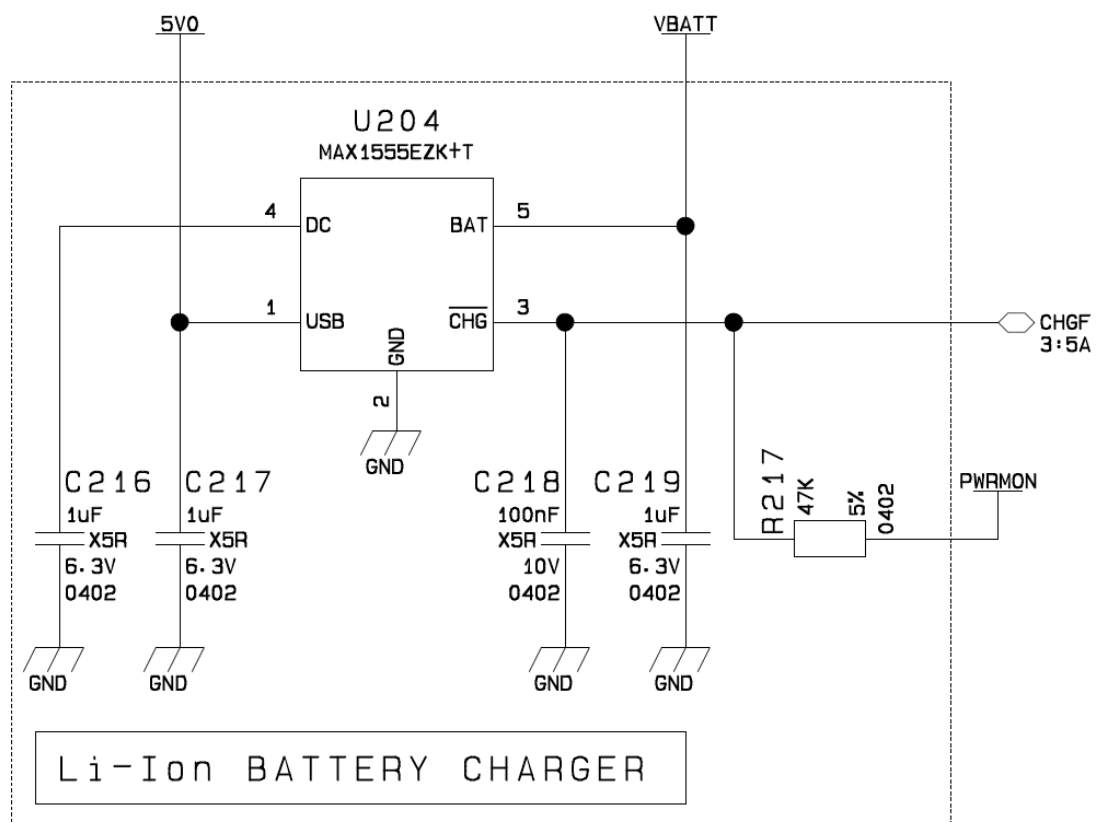

Fig 1: Battery Charger with 5V input power supply.

The MAX1555 charges the Li-Ion Cell by CCCV technique (Constant Current Constant Voltage).

If VBATT is less than 3 V, the device enters in pre-charge mode, where recharging current is limited to 40 mA. That low recharge current is suitable to “recover” an over-discharged cell.



Battery Charger Design Application Note
80000nt10042a Rev.1 - 2010-10-04

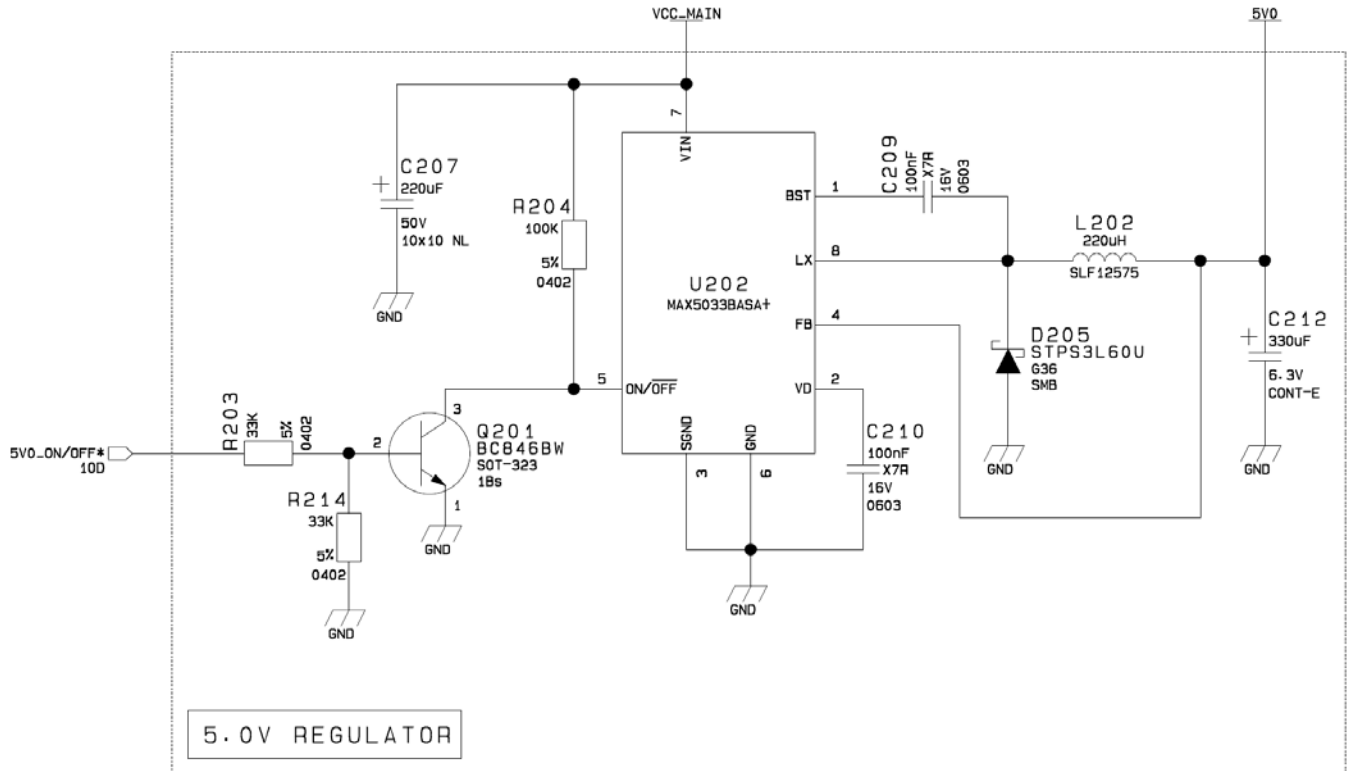

Fig.2: Wider input power supply voltage (up to 76 V DC input voltage).

