

## Features

- MINIATURE SIL PACKAGE
- FULLY SHIELDED
- DATA RATES UP TO 20KBITS/S
- NARROW BAND CRYSTAL TECHNOLOGY
- AVAILABLE ON 434.075 MHz
- WILL OPERATE IN PRESENCE OF 433.92 MHz TRANSMITTERS
- BETTER PERFORMANCE THAN SAW
- BASED 433.92 MHz FM MODULES
- WIDE OPERATING VOLTAGE (2.2 – 10 vdc)
- EN 300-220 compliant module

## Applications

- REMOTE CONTROL FOR CRANES ETC
- WIRELESS MONITORING
- DISPERSED ALARM APPLICATIONS
- DOMESTIC AND COMMERCIAL SECURITY

## General Description

The RS-MKT7 miniature transmitter UHF radio module enables the implementation of a wireless telemetry link at data rates of up to 20Kbit/s when used with the compatible RS-MKR7 receiver modules.

The transmitter is based on a classical phase lock loop using a crystal reference oscillator. This results in an accurately controlled RF output in the frequency domain. A significant advantage of this is that narrow filtering can then be used in the receiver which results in high interference immunity.

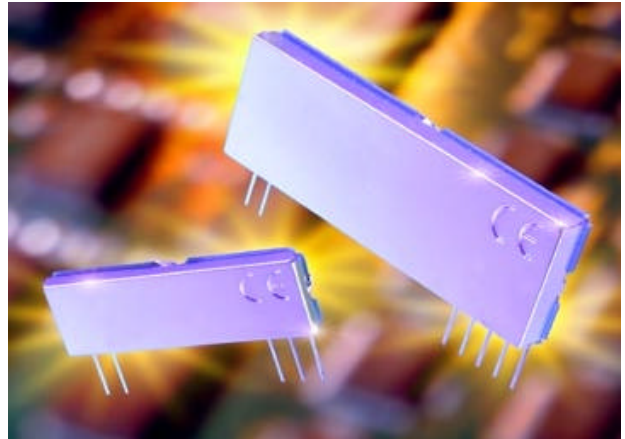

## Compatible Receiver Modules

- RS-MKR7-XXX (see data sheet RS-MKR7)

In addition, the module is fitted with an on board voltage regulator which enhances the module performance due to better supply filtering as well as ensuring a constant RF output level. The RS-MKT7 module will suit one-to-one and multi-node wireless links in applications including building and car security, remote industrial process monitoring and computer networking. Because of its small size and low power requirements, this module is ideal for use in portable battery powered wireless applications.

**Absolute Maximum Ratings: Transmitter**

Operating temperature:	-25°C to +55°C
Storage temperature:	-40°C to +100°C
Supply Voltage (pin 3)	10V
Data input (pin 5)	10V

**Electrical Characteristics: Transmitter**

	pin	min.	Typ.	max.	units	notes
<b>DC LEVELS</b>						
Supply voltage	3	2.2	5.0	10.0	Volts	
<b>Current &amp; RF POWER</b>						
434.075 MHz						
Supply current @ $V_{CC} = 5V$	3		7		mA	1
RF power	2		1		mW	1
<b>RF &amp; Data</b>						
2 <sup>nd</sup> harmonic			-60		dBm	2
Harmonics @ > 1GHz			-60		dBm	2
Initial frequency accuracy				±2	KHz	
Frequency accuracy over full temp range				±5	KHz	
Modulation bandwidth @ -3dB			20		KHz	3
Power up time to full RF						
			5		ms	
Data rate						
				20000	bits/s	
Data pulse width						
		50			µs	

- Note 1:** measured into a 50Ω impedance  
A 10mW version will be available Sept 2001.
- 2:** the limit for the European spec EN 300 220 is -36dBm
- 3:** A ±2.5 KHz FM deviation on the RF carrier is also available. Please consult sales desk.

## Connection Details

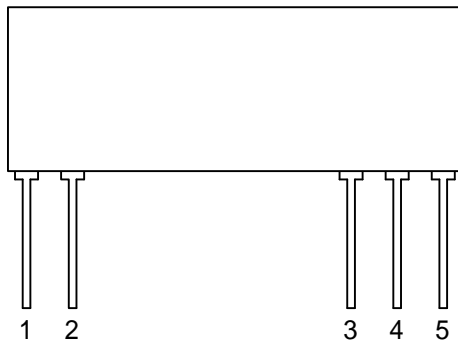

**Figure 1: MK Transmitter**

### Pin Description:

#### **RF GND (*pin 1*)**

RF ground pin, internally connected to pin 4 (0V). This pin should ideally be connected to the nearest ground plane (e.g. coax braid, main PCB ground plane etc.)

#### **RF OUT (*pin2*)**

50 $\Omega$  RF antenna output. To achieve best results the antenna impedance must match that of the module.

#### **V<sub>CC</sub> (*pin 3*)**

+Ve supply pin. The module will generate RF when V<sub>CC</sub> is present.

#### **GND (*pin 4*)**

Supply and data ground connection, connected to pin 1.

#### **Data IN (*pin 5*)**

This input has an impedance of 47K $\Omega$  and should ideally be driven by a CMOS logic drive or compatible. The drive circuitry should be supplied with the same supply voltage as the Tx module.

Application Information

Antenna Design

The design and positioning of the antenna is as crucial as the module performance itself in achieving a good wireless system range. The following will assist the designer in maximising system performance.

The antenna should be kept as far away from sources of electrical interference as physically possible. If necessary, additional power line decoupling capacitors should be placed close to the module.

The antenna ‘hot end’ should be kept clear of any objects, especially any metal as this can severely restrict the efficiency of the antenna to receive power. Any earth planes restricting the radiation path to the antenna will also have the same effect.

Best range is achieved with either a straight piece of wire, rod or PCB track @ ¼ wavelength (15.5cm @ 434 MHz). Further range may be achieved if the ¼ wave antenna is placed perpendicular in the middle of a solid earth plane measuring at least 30cm radius. In this case, the antenna should be connected to the module via some 50 ohm characteristic impedance coax

Application Circuit

The application circuit shows how the MKT7 transmitter can easily be integrated into a system to form a wireless link

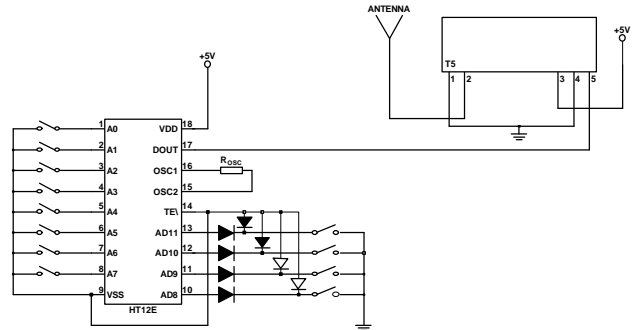

Figure 3: MK Transmitter Application Circuit

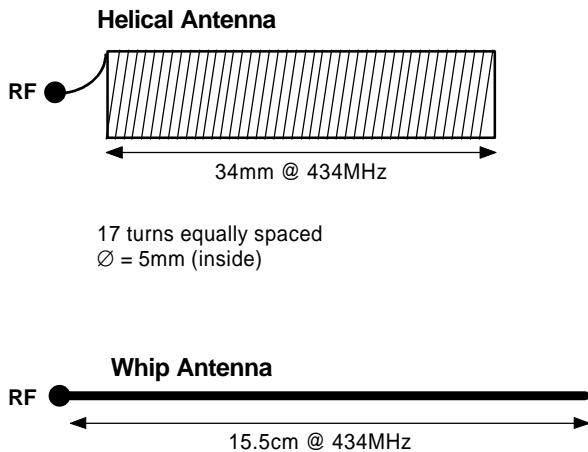
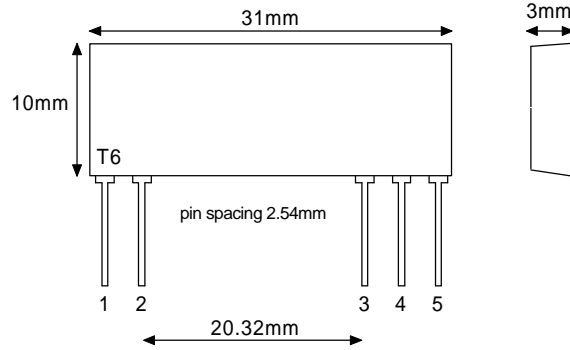

Figure 2: Antenna Configurations To Be Used With The MKT7 Transmitter Modules

**Mechanical Dimensions**



**Figure 4: MK Transmitter**

**Ordering Information**

Standard Product;

Part No	Description
RS-MKT7-434-075	Narrow Band FM Transmitter 434,075 MHz

Round Solutions Ltd.  
 Niederlassung Deutschland  
 Zaunweg 4  
 D-63303 Dreieich  
 Tel. 06103 960510  
 Fax. 06103 960509

[www.roundsolutions.com](http://www.roundsolutions.com)  
[info@roundsolutions.com](mailto:info@roundsolutions.com)