

## Features

- MINIATURE SIL PACKAGE
- FULLY SHIELDED
- DATA RATES UP TO 128KBITS/S
- 5v – 10mW  
5v – 25mW, and  
3v – 10mW versions available
- TYPICAL RANGE 350+ m (433.92 MHz Version)
- 315 / 318 / 418 / 433.92 MHz VERSIONS
- INDUSTRY PIN COMPATIBLE
- EN 300-220 compliant module

## Applications

- VEHICLE ALARM SYSTEMS
- REMOTE GATE CONTROLS
- GARAGE DOOR OPENERS
- DOMESTIC AND COMMERCIAL SECURITY

## General Description

The RS-MKT5 miniature transmitter UHF radio module enables the implementation of a simple telemetry link at data rates of up to 128Kbit/s when used with the compatible MKR5 receiver modules.

Available for operation at all world frequencies these modules are able to transmit at distances of up to 350+ m (433.92 MHz version).

## Compatible Receiver Modules

- RS-MKR5-XXX (see data sheet RS-MKR5)

The RS-MKT5 module will suit one-to-one and multi-node wireless links in applications including building and car security, remote industrial process monitoring and computer networking. Because of its small size and low power requirements, this module is ideal for use in portable battery powered wireless applications.

**Absolute Maximum Ratings: Transmitter**

Operating temperature:	-20°C to +55°C
Storage temperature:	-40°C to +100°C
Supply Voltage (pin 3)	10V
Data input (pin 5)	10V
RF Out (pin 2)	±50V @ < 10MHz , +20dBm @ > 10MHz

**Electrical Characteristics: Transmitter 433,92 MHz**

	pin	min.	Typ.	max.	units	notes
<b>5v Transmitter</b>						
Supply voltage	3	4.0	5.0	6.0	Volts	
Supply current	3	5.5	7	9.2	mA	1
RF power	2	7	10	+12	dBm	1
<b>3v Transmitter</b>						
Supply voltage	3	2	3	4	Volts	
Supply current	3	3	5	7	mA	1
RF power	2	4	7	10	dBm	1
<b>RF &amp; Data</b>						
2 <sup>nd</sup> harmonic			-50		dBm	2
Harmonics @ > 1GHz			-50		dBm	2
Initial frequency accuracy			±75		KHz	
Modulation bandwidth @ -3dB			25		KHz	3
Modulation distortion (THD)					%	
Power up time to full RF			10		µs	
Data rate				50000	bits/s	3
Data pulse width		20			µs	

- Note** 1: measured into a 50Ω impedance  
 2: the limit for the European spec EN 300 220 is -36dBm  
 3: 128 kbits/sec version also available

## Connection Details

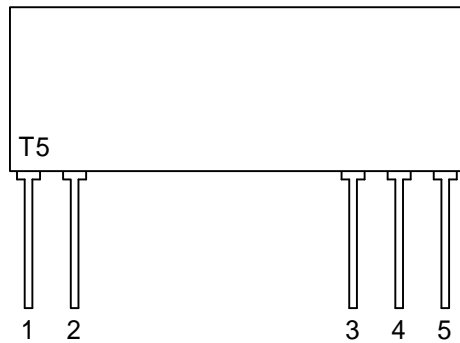

Figure 1: MK Transmitter

### Pin Description:

#### **RF GND (pin 1)**

RF ground pin, internally connected to pin 4 (0V). This pin should ideally be connected to the nearest ground plane (e.g. coax braid, main PCB ground plane etc.)

#### **RF OUT (pin2)**

50 $\Omega$  RF antenna output. To achieve best results the antenna impedance must match that of the module.

#### **V<sub>CC</sub> (pin 3)**

+Ve supply pin. The module will generate RF when V<sub>CC</sub> is present. It is strongly recommended that a 100nF capacitor decouples the supply rail as close as possible to this pin.

#### **GND (pin 4)**

Supply and data ground connection, connected to pin 1.

#### **Data IN (pin 5)**

This input has an impedance of 47K $\Omega$  and should ideally be driven by a CMOS logic drive or compatible. The drive circuitry should be supplied with the same supply voltage as the Tx module.

Application Information

Antenna Design

The design and positioning of the antenna is as crucial as the module performance itself in achieving a good wireless system range. The following will assist the designer in maximising system performance.

The antenna should be kept as far away from sources of electrical interference as physically possible. If necessary, additional power line decoupling capacitors should be placed close to the module.

The antenna ‘hot end’ should be kept clear of any objects, especially any metal as this can severely restrict the efficiency of the antenna to receive power. Any earth planes restricting the radiation path to the antenna will also have the same effect.

Best range is achieved with either a straight piece of wire, rod or PCB track @ ¼ wavelength (15.5cm @ 433.92MHz). Further range may be achieved if the ¼ wave antenna is placed perpendicular in the middle of a solid earth plane measuring at least 16cm radius. In this case, the antenna should be connected to the module via some 50 ohm characteristic impedance coax.

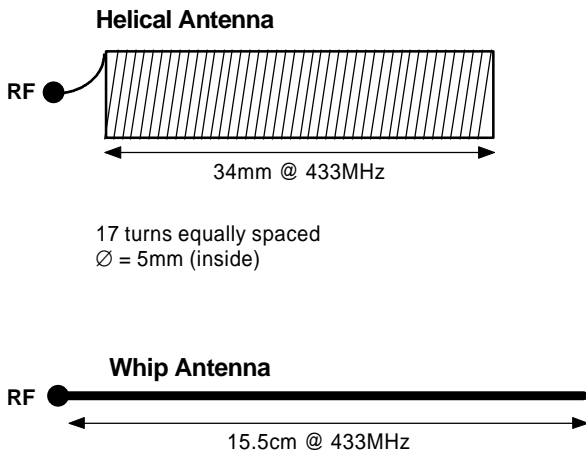

Figure 2: Antenna Configurations To Be Used With The MKT5 Transmitter Modules

Application Circuit

The application circuit shows how the MKT5 transmitter can easily be integrated into a system to form a wireless link

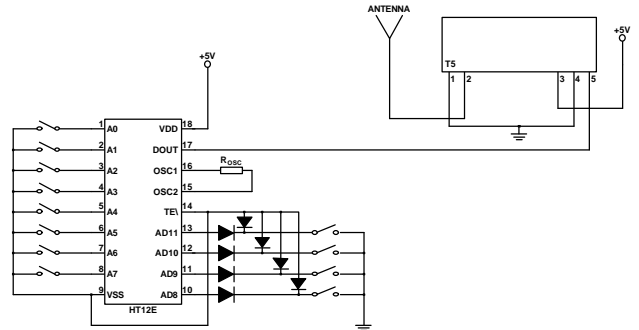
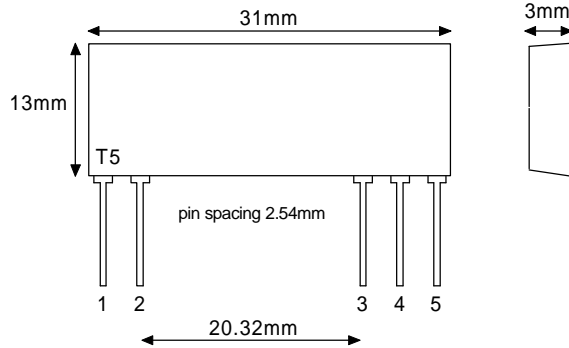

Figure 3: MK Transmitter Application Circuit

**Mechanical Dimensions**



**Figure 4: MK Transmitter**

**Ordering Information**

**Standard Product;**

Part No	Description
RS-MKT5-418*	SIL Transmitter 418.00 MHz
RS-MKT5-434-3-XX	3v SIL Transmitter
RS-MKT5-434-5-XX	5v SIL Transmitter 433.92 MHz
* Not recommended for new designs as this frequency allocation will be withdrawn in the UK.	
XX- Please specify data rate. Up to 50 or 128 Kbps.	

Round Solutions Ltd.  
 Niederlassung Deutschland  
 Zaubweg 4  
 D-63303 Dreieich  
 Tel. 06103 960510  
 Fax. 06103 960509

[www.roundsolutions.com](http://www.roundsolutions.com)  
[info@roundsolutions.com](mailto:info@roundsolutions.com)