

Features

- MINIATURE SIL PACKAGE
- UNIQUE HIGH POWER AM DESIGN
- DATA RATES UP TO 10KBITS/S
- OPTIMAL RANGE 300 m (433.92 MHz Version)
- 315 / 318 / 418 / 433.92 / 868 & 916 MHz VERSIONS
- 3 TO 9 VOLT SUPPLY VOLTAGE
- INDUSTRY PIN COMPATIBLE
- EN 300-220 Approved module

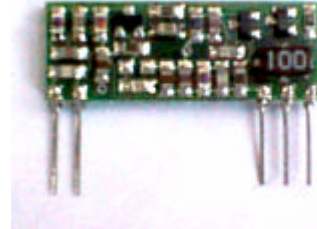

Applications

- VEHICLE ALARM SYSTEMS
- REMOTE GATE CONTROLS
- GARAGE DOOR OPENERS
- DOMESTIC AND COMMERCIAL SECURITY

Compatible Receiver Modules

- RS-MKR1-XXX (see data sheet RS-MKR1)
- RS-MKR2AM-XXX (see data sheet RS-MKR2AM)

General Description

The RS-MKT1HP-XXX miniature transmitter UHF radio module enables the implementation of a simple telemetry link at data rates of up to 10Kbit/s when used with one of the compatible MK receiver modules.

Available for operation at all world frequencies these modules are able to transmit at distances of up to 300 m (433.92 MHz version) when used in conjunction with the RS-MKR1 receiver.

The RS-MKT1HP-XXX module will suit one-to-one and multi-node wireless links in applications including building and car security, remote industrial process monitoring and computer networking. Because of its small size and low power requirements, this module is ideal for use in portable battery powered wireless applications.

Absolute Maximum Ratings: Transmitter

Operating temperature:	-20°C to +55°C
Storage temperature:	-40°C to +100°C
Supply Voltage (pin 3)	10V
Data input (pin 5)	10V
RF Out (pin 2)	±50V @ < 10MHz , +20dBm @ > 10MHz

Electrical Characteristics: Transmitter

	pin	min.	Typ.	max.	units	notes
DC LEVELS						
Supply voltage	3	3.0	5.0	9.0	Volts	
Current & RF POWER @ 5volts supply						
433.92 MHz						
Supply current @ V _{CC} = 5V (data low/high)	3			5/15	mA	1
RF power	2		9	+12	dBm	1
RF & Data						
2 nd harmonic			-50		dBc	1
Harmonics @ > 1GHz			-46		dBc	1
Initial frequency accuracy			±75		KHz	
Overall frequency accuracy			±120		KHz	
Modulation bandwidth @ -3dB			20		KHz	
Modulation distortion (THD)					%	
Power up time to full RF			10		µs	
Data rate		100		10000	bits/s	
Data pulse width		75			µs	

Note 1: measured into a 50Ω impedance

Connection Details

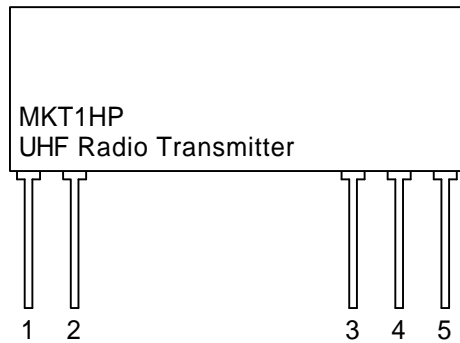

Figure 1: MK Transmitter

Pin Description

RF GND (*pin 1*)

RF ground pin, internally connected to pin 4 (0V). This pin should ideally be connected to the nearest ground plane (e.g. coax braid, main PCB ground plane etc.)

RF OUT (*pin2*)

50 Ω RF antenna output. To achieve best results the antenna impedance must match that of the module.

V_{CC} (*pin 3*)

+Ve supply pin (3.0 to 9.0 volts). The module will generate RF when V_{CC} is present. It is strongly recommended that a 100nF capacitor decouples the supply rail as close as possible to this pin.

GND (*pin 4*)

Supply and data ground connection, connected to pin 1.

Data IN (*pin 5*)

This input has an impedance of 47K Ω and should ideally be driven by a CMOS logic drive or compatible. The drive circuitry should be supplied with the same supply voltage as the Tx module.

Application Information

Antenna Design

The design and positioning of the antenna is as crucial as the module performance itself in achieving a good wireless system range. The following will assist the designer in maximising system performance.

The antenna should be kept as far away from sources of electrical interference as physically possible. If necessary, additional power line decoupling capacitors should be placed close to the module.

The antenna ‘hot end’ should be kept clear of any objects, especially any metal as this can severely restrict the efficiency of the antenna to receive power. Any earth planes restricting the radiation path to the antenna will also have the same effect.

Best range is achieved with either a straight piece of wire, rod or PCB track @ ¼ wavelength (15.5cm @ 433.92MHz). Further range may be achieved if the ¼ wave antenna is placed perpendicular in the middle of a solid earth plane measuring at least 16cm radius. In this case, the antenna should be connected to the module via some 50 ohm characteristic impedance coax

Application Circuit

The application circuit shows how the MKT1 transmitter can easily be integrated into a system to form a wireless link.

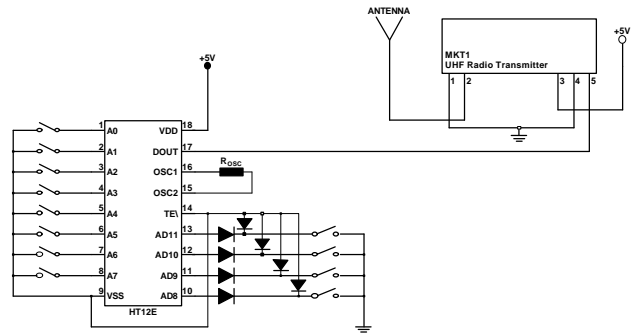

Figure 3: MK Transmitter Application Circuit

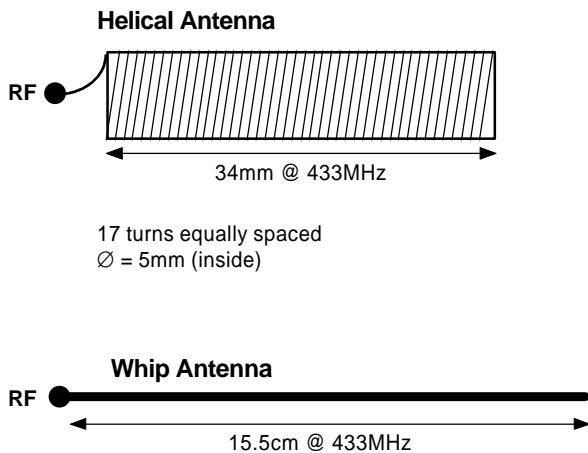

Figure 2: Antenna Configurations To Be Used With The MKT1 Transmitter Module

Mechanical Dimensions

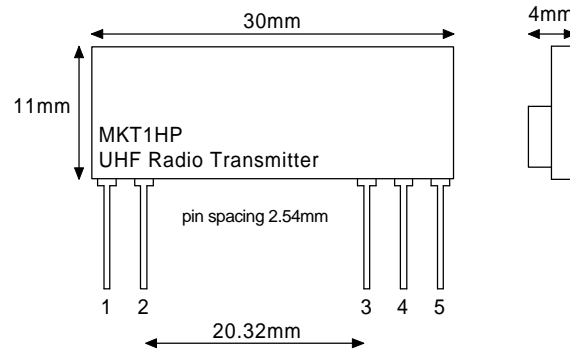

Figure 4: MK Transmitter

Ordering Information

Standard Product;

Part No	Description
RS-MKT1HP-434	SIL Transmitter 434,92 MHz
RS-MKT1HP-868	SIL Transmitter 868,35 MHz
RS-MKT1HP-916	SIL Transmitter 916,5 MHz

Round Solutions Ltd.
Niederlassung Deutschland
Zaunweg 4
D-63303 Dreieich
Tel. 06103 960510
Fax. 06103 960509

www.roundsolutions.com
info@roundsolutions.com