

Features

- Miniature SIL package
- Single conversion FM Super-het using RF SAW and ceramic IF filtering at 10.7 MHz. (Image rejection 50dB)
- Dynamic range better than 120dB
- Fully shielded
- Analogue, Digital and true RSSI outputs
- DATA RATES UP TO 64KBITS/S
- Operation on 868.45, 869.85 & 914.5 MHz
- HIGH SENSITIVITY (-103 dBm)
- Very low current consumption (6mA)
- SINGLE 5V SUPPLY

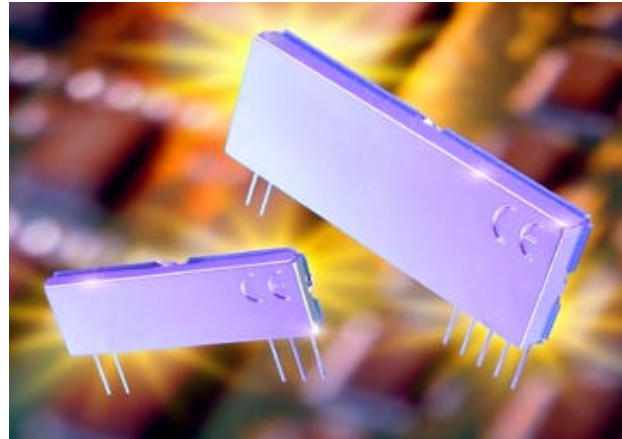

Applications

- Telemetry systems
- Remote switching applications
- Paging systems
- Domestic and commercial security

General Description

The RS-MKR6 miniature receiver UHF radio module enables the implementation of a reliable telemetry link at data rates of up to 64Kbit/s when used with one of the compatible RS-MK transmitter modules

The receiver is based on the classical single conversion superhet principle utilising a crystal based phase lock loop for accurate generation of the local oscillator. This allows use of high Q bandpass filters resulting in good adjacent channel selectivity and high interference immunity.

Compatible Transmitter Modules

- RS-MKT6-XXX (see data sheet RS-MKT6)

The RS-MKR6 module will suit one-to-one and multi-node wireless links in applications including building and car security, remote industrial process monitoring and computer networking. Because of its small size and low power requirements, the module is ideal for use in portable battery powered wireless applications

The module is highly suited for operation in harsh electrical environments where a reliable wireless link is essential.

Absolute Maximum Ratings: Receiver

Operating temperature:	-10°C to +55°C -40 to +80 deg C option available
Storage temperature:	-40°C to +100°C
Supply Voltage (pin 5) RF Input (pin 1)	7V +20 dBm (100mW)

Electrical Characteristics: Receiver (20 Kbits/sec version)

	pin	min.	typ.	max.	units	notes
DC LEVELS						
Supply voltage		4.5	5	5.5	V	
Supply current			6		mA	
Supply ripple		-	-	10	mV _{P-P}	
Data output high			=>4.5		V	
Data output low			<= 0.5		V	
RF						
RF sensitivity			-103		dBm	
IF Bandwidth			230		KHz	1
Initial frequency accuracy			±30		KHz	
Max R.F. input			20		dBm	
E.M.C.						
Spurious responses upto 1GHz			<60		dB	
LO leakage, conducted			<60		dBm	
LO leakage, radiated			<60		dBm	
Image rejection			50		dB	
DYNAMIC TIMING						
Power up to stable data <i>(With RF signal present)</i>			25	30	mS	20kbps
			5	7		64 kbps
Signal to stable data <i>(With power supply already on)</i>			5		mS	20kbps
			2			64kbps
Power up to valid RSSI <i>(with RF signal present)</i>			1	2	mS	
Mark:space ratio			50		%	2
Allowable data pulse widths		50		6000	uS	20kbps
		12		800		64kbps

Notes

- 1) IF bandwidth available down to 27KHz.
- 2) The data slicer is optimised for a 50:50 duty cycle, henc for reliable communications data should be encoded using a suitable scheme such as Manchester Encoding, although pulse width modulation uo to 30:70/70:30 can also be utilised.

Connection Details

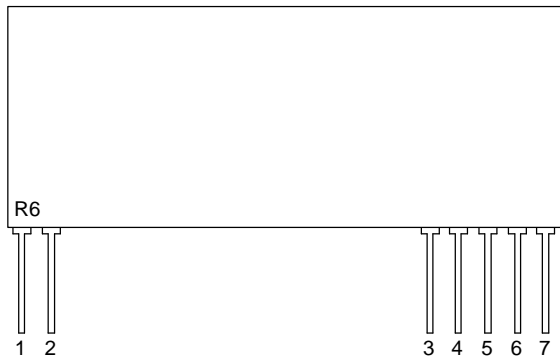

Figure 1: RS-MKR6 Receiver

Pin Description

RF IN (*pin 1*)

50 Ω RF input from antenna, connect using shortest possible route. This input is isolated from the internal circuit using the air gap of the front end SAW RF filter.

RF GND (*pin 2*)

RF ground connection, preferably connected to a solid ground plane.

RSSI / Carrier Detect (*pin 3*)

The Received Signal Strength Indicator provides a DC output voltage proportional to the RF input signal. The amplitude of the RSSI voltage increases with increasing RF signal strength. A simple transistor interface can yield a carrier detect logic output.

Gnd (*pin 4*)

Connect to power supply ground.

V_{CC} (*pin 5*)

+Ve supply pin. Operation from a 5V supply able to source 10mA at less than 10mV_{P,P} ripple.

AF (*pin 6*)

Audio frequency output (max 40uA source).

DATA OUT (*pin 7*)

CMOS compatible output. This may be used to drive external decoders.

Application Information

Antenna Design

The design and positioning of the antenna is as crucial as the module performance itself in achieving a good wireless system range. The following will assist the designer in maximising system performance.

The antenna should be kept as far away from sources of electrical interference as physically possible. If necessary, additional power line decoupling capacitors should be placed close to the module.

The antenna 'hot end' should be kept clear of any objects, especially any metal as this can severely restrict the efficiency of the antenna to receive power. Any earth planes restricting the radiation path to the antenna will also have the same effect.

Best range is achieved with either a straight piece of wire, rod or PCB track @ ¼wavelength (7.5cm @ 868 MHz). Further range may be achieved if the ¼ wave antenna is placed perpendicular in the middle of a solid earth plane measuring at least 10cm radius. In this case, the antenna should be connected to the module via some 50 ohm characteristic impedance coax.

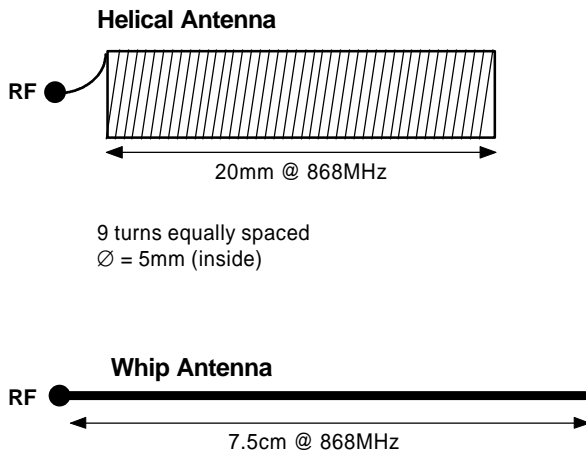

Figure 2: Antenna Configurations To Be Used With The RS-MK receiver Module

Application Circuit

The application circuit shows how the RS-MKR6 Receiver can easily be integrated into a system to form a wireless link.

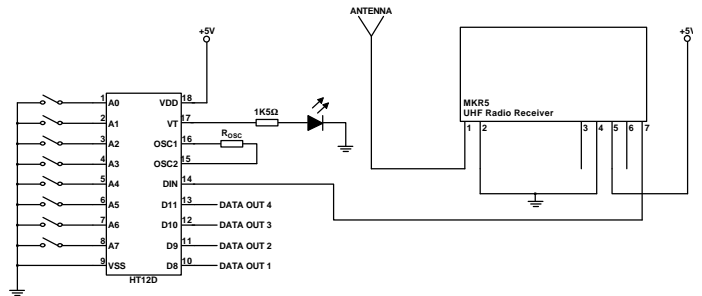

Figure 3: RS-MK Receiver Application Circuit

RSSI Values

The RS-MKR6 RSSI output provides a DC output proportional to the RF input signal. The table below shows the typical RSSI value depending on the RF signal strength.

RF Signal Strength / dBm	RSSI / V
-110	1,22
-100	1,38
-90	1,63
-80	1,9
-70	2,22
-60	2,50
-50	2,65
-40	2,66
-30	2,66

Mechanical Dimensions

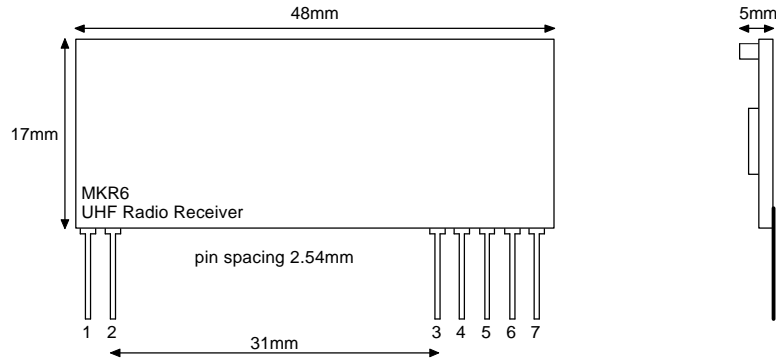

Figure 4: RS-MKR6 Receiver

Ordering Information

Standard Product;

Part No	Description
RS-MKR6-868.4-5-XX	XX Kbits/sec FM Receiver 868,40 MHz
RS-MKR6-869.85-5-XX	XX Kbits/sec FM Receiver 869,85 MHz
RS-MKR6-914.5-5-XX	XX Kbits/sec FM Receiver 914.5,00 MHz
XX = Please specify 20 or 64 Kbits/sec data rate	

Round Solutions Ltd.
Niederlassung Deutschland
Zaunweg 4
D-63303 Dreieich
Tel. 06103 960510
Fax. 06103 960509

www.roundsolutions.com
info@roundsolutions.com