

## The Best AM receiver module!

### Features

- Single conversion FM Super-het using RF SAW and ceramic IF filtering at 10.7 MHz.
- (Image rejection 50dB)
- Dynamic range better than 100dB
- Fully shielded
- Analogue, Digital and true RSSI outputs
- 350m range with RS-MKT1HP transmitter
- Operation on 433.92 MHz
- HIGH SENSITIVITY (-112 dBm)
- Very low current consumption (6mA)
- SINGLE 5V SUPPLY

### Applications

- Telemetry systems
- Remote switching applications
- Paging systems
- Domestic and commercial security

### General Description

The RS-MKR5A miniature receiver UHF radio module enables the implementation of a **reliable** telemetry link at data rates of up to 10Kbit/s when used with one of the compatible RS-MK transmitter modules

Available for operation at 433.92 MHz these modules are able to receive at distances of up to 350metres.

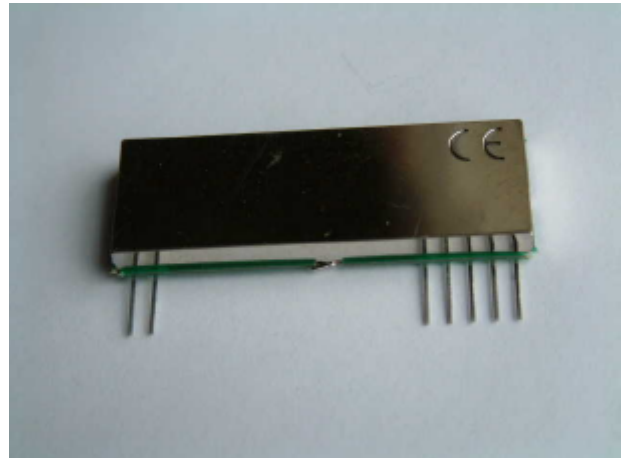

### Compatible Transmitter Modules

- RS-MKT1-XXX
- RS-MKT1HP

The receiver is based on the classical superhet single conversion architecture utilising a PLL xtal referenced oscillator which yields a highly stable IF frequency (10.7 MHz). This hence allows use of high Q bandpass filters offering excellent adjacent channel rejection and hence high interference immunity. In addition a SAW front end filter is used.

The RS-MKR5A module will suit one-to-one and multi-node wireless links in applications including building and car security, remote industrial process monitoring and computer networking. Because of its small size and low power requirements, including a fast RSSI/CD, the module is ideal for use in portable battery powered wireless applications.

The module is highly suited for operation in harsh electrical environments where a reliable wireless link is essential.

**Absolute Maximum Ratings: Receiver**

Operating temperature:	-20°C to +55°C -40 to +80 deg C option available
Storage temperature:	-40°C to +100°C
Supply Voltage (pin 5)	7V
RF Input (pin 1)	-10 dBm

**Electrical Characteristics: Receiver** (measured at room temperature)

	pin	min.	typ.	max.	units	notes
<b>DC LEVELS</b>						
Supply voltage		4.5	5	5.5	V	
Supply current			6.0		mA	
Supply ripple		-	-	10	mV <sub>P-P</sub>	
Data output high			=>4.0		V	
Data output low			<= 0.5		V	
<b>RF</b>						
RF sensitivity			-112		dBm	
IF Bandwidth			230		KHz	1
Initial frequency accuracy			±25		KHz	
Max R.F. input			20		dBm	
<b>E.M.C.</b>						
Spurious responses upto 1GHz			<60		dB	
LO leakage, conducted			<60		dBm	
LO leakage, radiated			<60		dBm	
Image rejection			50		dB	
<b>DYNAMIC TIMINGS</b>						
<b>Power up to stable data (With RF signal present)</b>			30	35	mS	
<b>Signal to stable data (With power supply already on)</b>				2.5	mS	
<b>Power up to valid RSSI (with RF signal present)</b>				1	mS	
<b>Allowable data pulse widths (see note 2)</b>		100		6000	uS	

**Notes**

- 1) IF bandwidth available down to 27KHz
- 2) The data slicer is optimised for a 50:50 duty cycle, hence for reliable communications data should be encoded using a suitable scheme such as Manchester Encoding, although pulse width modulation up to 30:70/70:30 can also be utilised.

## Connection Details

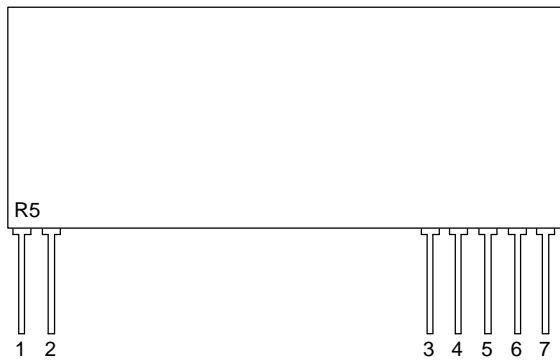

Figure 1: RS-MKR5A Receiver

## Pin Description

### RF IN (*pin 1*)

50Ω RF input from antenna, connect using shortest possible route. This input is isolated from the internal circuit using the air gap of the front end SAW RF filter.

### RF GND (*pin 2*)

RF ground connection, preferably connected to a solid ground plane.

### RSSI / Carrier Detect (*pin 3*)

The Received Signal Strength Indicator provides a DC output voltage proportional to the RF input signal. The amplitude of the RSSI voltage increases with increasing RF signal strength. A simple transistor interface can yield a carrier detect logic output.

### Gnd (*pin 4*)

Connect to power supply ground

### V<sub>CC</sub> (*pin 5*)

+Ve supply pin. Operation from a 5V supply able to source 6mA at less than 10mV<sub>P-P</sub> ripple.

### AF (*pin 6*)

Audio frequency output

### DATA OUT (*pin 7*)

CMOS compatible output. This may be used to drive external decoders.

Application Information

Antenna Design

The design and positioning of the antenna is as crucial as the module performance itself in achieving a good wireless system range. The following will assist the designer in maximising system performance.

The antenna should be kept as far away from sources of electrical interference as physically possible. If necessary, additional power line decoupling capacitors should be placed close to the module.

The antenna 'hot end' should be kept clear of any objects, especially any metal as this can severely restrict the efficiency of the antenna to receive power. Any earth planes restricting the radiation path to the antenna will also have the same effect.

Best range is achieved with either a straight piece of wire, rod or PCB track @ ¼ wavelength (15.5cm @ 433.92MHz). Further range may be achieved if the ¼ wave antenna is placed perpendicular in the middle of a solid earth plane measuring at least 16cm radius. In this case, the antenna should be connected to the module via some 50 ohm characteristic impedance coax.

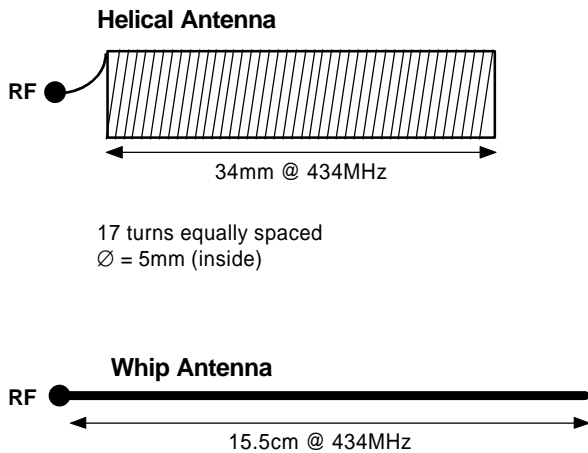

Figure 2: Antenna Configurations To Be Used With The RS-MK receiver Module

Application Circuit

The application circuit shows how the RS-MKR5A Receiver can easily be integrated into a system to form a wireless link.

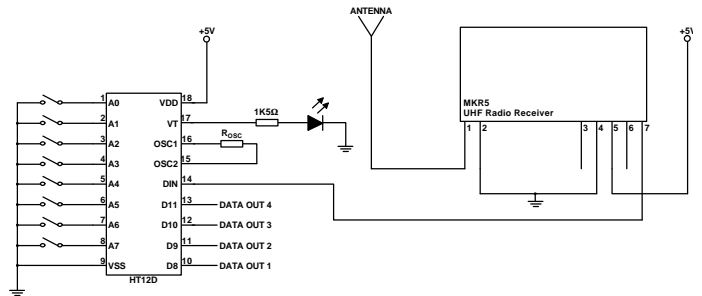

Figure 3: RS-MK Receiver Application Circuit

RSSI Values

The RS-MKR5A RSSI output provides a DC output proportional to the RF input signal. The table below shows the typical RSSI value depending on the RF signal strength.

RF Signal Strength / dBm	RSSI / V
-120	1.27
-110	1.33
-100	1.49
-90	1.74
-80	1.99
-70	2.3
-60	2.56
-50	2.63
-40	2.63

**Mechanical Dimensions**

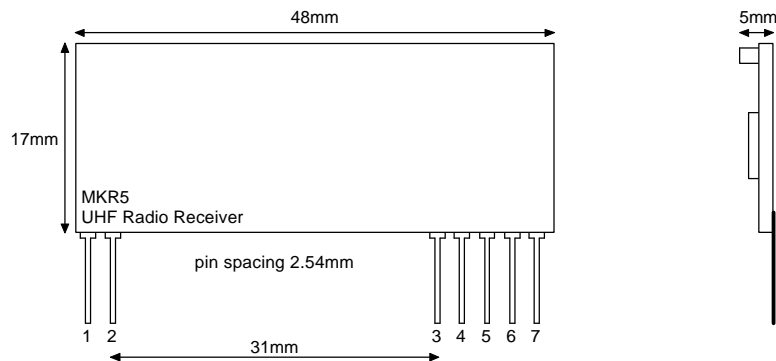

**Figure 4: RS-MKR5A Receiver**

**Ordering Information**

**Standard Product;**

Part No	Description
RS-MKR5A-434-5	AM Receiver 433.92MHz
RS-MKR5A-315-5	AM Receiver 315 MHz
RS-MKR5A-868-5	AM Receiver 868.35 MHz

RS-MKR5ALC – This version is a low cost pin compatible version without shielding can and front end SAW filter.

**Please consult our sales department for further information.**

Round Solutions Ltd  
 German Branch  
 Zaunweg 4  
 D-63303 Dreieich  
 Germany

Tel: +49 (0) 6103 960510  
 Fax: +49 (0) 6103 960509

Email: [info@roundsolutions.com](mailto:info@roundsolutions.com)  
 Web: [www.roundsolutions.com](http://www.roundsolutions.com)

**Disclaimer**

Round Solutions have a policy to continually improve the reliability and performance of their products. We therefore reserve the right to upgrade our products performance without notice. Although the data contained herewith is believed to be accurate, however we do not assume any responsibility whatsoever for errors or omissions this document may contain. In addition, we do not imply warranty or fitness for any purpose especially life support applications for this product.