

## Features

- MINIATURE SIL PACKAGE
- SINGLE CONVERSION FM SUPERHET
- 10.7 MHz HIGH REJECTION IF FILTER
- DATA RATES UP TO 20KBITS/S
- 433.92 MHz
- HIGH RECEIVE SENSITIVITY (-103 dBm)
- VERY LOW CURRENT CONSUMPTION
- SINGLE 5V SUPPLY
- DIGITAL, AUDIO & RSSI OUTPUT

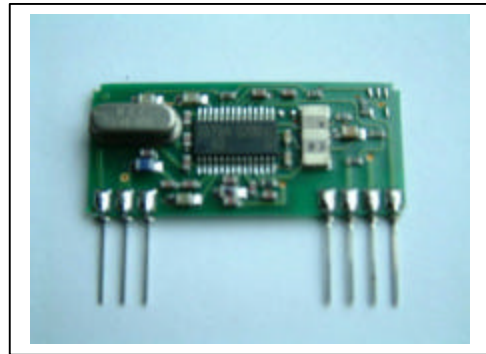

## Applications

- VEHICLE ALARM SYSTEMS
- REMOTE GATE CONTROLS
- GARAGE DOOR OPENERS
- DOMESTIC AND COMMERCIAL SECURITY

## Compatible Transmitter Modules

- RS-MKT5
- RS-MKT5LC

## General Description

The RS-MKR2FM miniature receiver UHF radio module enables the implementation of a simple telemetry link at data rates of up to 20Kbit/s when used with one of the compatible RS-MK transmitter modules

Available for operation at 433.92 MHz, these modules are able to receive at distances of up to 300m.

The RS-MKR2FM module will suit one-to-one and multi-node wireless links in applications including building and car security, remote industrial process monitoring and computer networking. Because of its small size and low power requirements, the module is ideal for use in portable battery powered wireless applications.

**Absolute Maximum Ratings: Receiver**

Operating temperature:	-10°C to +55°C
Storage temperature:	-40°C to +100°C
Supply Voltage (pin 1)	5V
RF input (pin 3)	± 50V @ < 10 MHz, +20 dBm @ > 10 MHz

**Electrical Characteristics: Receiver**

	pin	min.	typ.	max.	units	notes
<b>DC LEVELS</b>						
Supply voltage		4,5	5	5,5	V	
Supply current			4,5		mA	
Supply ripple		-	-	10	mV <sub>p-p</sub>	
Data output high			4,0		V	
Data output low			<=0,5		V	
<b>RF</b>						
RF sensitivity @ 433.92 MHz			-103		dBm	
IF Bandwidth			230		KHz	
Initial frequency accuracy			±10		KHz	
Max R.F. input			-5		dBm	
<b>E.M.C.</b>						
Spurious responses upto 1 GHz			<60		dB	
LO leakage, conducted			<60		dBm	
LO leakage, radiated			<60		dBm	
<b>DYNAMIC TIMING</b>						
Power up with signal present:						
Power up to stable data			20		mS	
Power up to valid RSSI				1mS		
Signal applied with supply on						
Signal to stable data			5		mS	
Bit rate		200		20000	bps	

The data slicer is optimised for a 50:50 duty cycle, hence for reliable communications data should be encoded using a suitable scheme such as Manchester Encoding, although pulse width modulation up to 3-:70 / 70:30 can also be utilised.

Connection Details

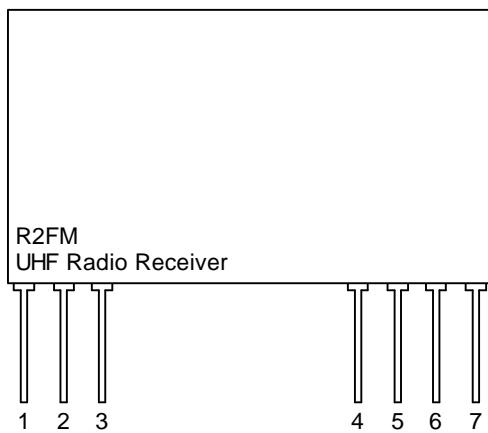

Figure 1: RS-MKR2FM Receiver

Pin Description

**V<sub>CC</sub> (pin 1)**

+Ve supply pin. Operation from a 5V supply able to source 10mA at less than 10mV<sub>P,P</sub> ripple.

**GND (pin2)**

Supply ground connection, preferably connected to a solid ground plane.

**RF IN (pin 3)**

50Ω RF input from antenna, connect using shortest possible route. Capacitively isolated from internal circuit.

**UNCONNECTED (pins 4)**

Extra SIL pin for additional mechanical retention.

**AF (PIN 5)**

Audio frequency output. Note source current is limited to 40uA. In most applications a buffer may be required to interface to this pin.

**RSSI (pin 6)**

This is a dc output voltage that is proportional to the RF signal strength applied to pin 3.

**DATA OUT (pin 7)**

CMOS compatible output. This may be used to drive external decoders.

General Information

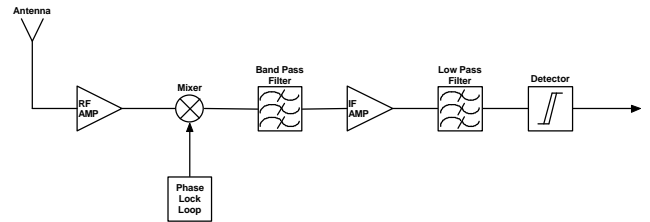

Figure 2:- RS-MKR2FM Receiver Block Diagram

The RS-MKR2FM receiver module is a FM single conversion superhet receiver capable of handling data rates of up to 10Kbits/s. With an on board data buffer, phase locked loop and a high quality front end RF stage a -103 dBm sensitivity is achieved.

Utilising the latest phase locked loop receiver technology with one of the compatible RS-MK transmitter modules will yield a highly efficient wireless link.

Application Information

Antenna Design

The design and positioning of the antenna is as crucial as the module performance itself in achieving a good wireless system range. The following will assist the designer in maximising system performance.

The antenna should be kept as far away from sources of electrical interference as physically possible. If necessary, additional power line decoupling capacitors should be placed close to the module.

The antenna ‘hot end’ should be kept clear of any objects, especially any metal as this can severely restrict the efficiency of the antenna to receive power. Any earth planes restricting the radiation path to the antenna will also have the same effect.

Best range is achieved with either a straight piece of wire, rod or PCB track @ ¼wavelength (17cm @ 433.92 MHz). Further range may be achieved if the ¼wave antenna is placed perpendicular in the middle of a solid earth plane measuring at least 20cm radius. In this case, the antenna should be connected to the module via some 50 ohm characteristic impedance coax

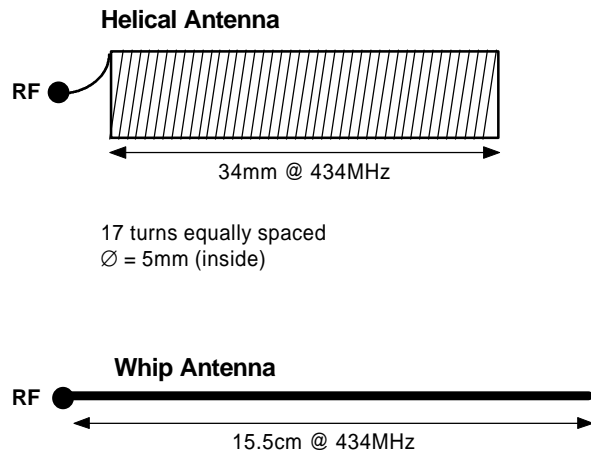

Figure 3: Antenna configurations to be used with the RS-MK modules

Application Circuit

The application circuit shows how the RS-MKR2FM receiver can easily be integrated into a system to form a wireless link.

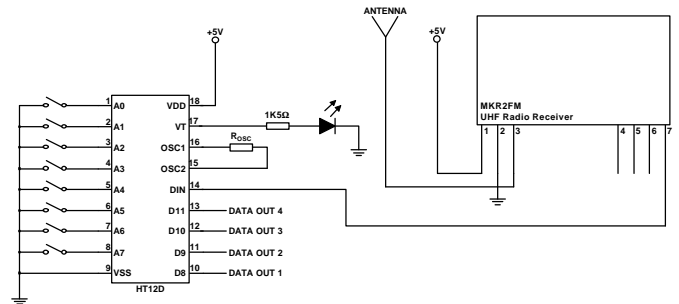
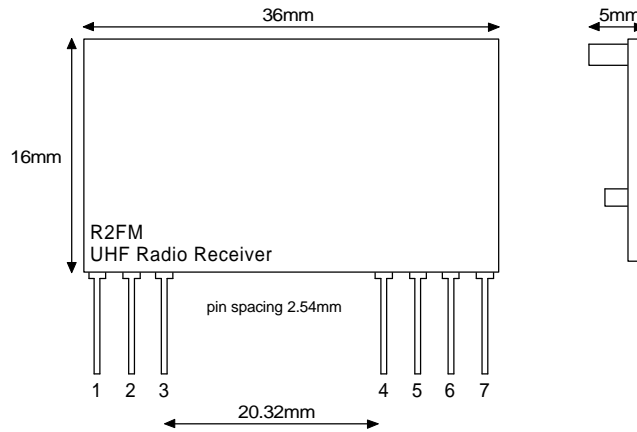

Figure 4: RS-MKR2FM Receiver Application Circuit

**Mechanical Dimensions**



**Figure 5: RS-MKR2FM Receiver**

**Ordering Information**

Standard Product;

Part No	Description
RS-MKR2FM-434	433.92 MHz FM Receiver

Please consult our sales department for further information.

**Round Solutions Ltd.**  
**Niederlassung Deutschland**  
**Zaunweg 4**  
**D-63303 Dreieich**  
**Tel. 06103 960510**  
**Fax. 06103 960509**

[www.roundsolutions.com](http://www.roundsolutions.com)  
[info@roundsolutions.com](mailto:info@roundsolutions.com)