

Features

- MINIATURE SIL PACKAGE
- SINGLE CONVERSION FM SUPERHET
- 10.7 MHz HIGH REJECTION IF FILTER
- DATA RATES UP TO 10KBITS/S
- 433.92, 868.35 & 916.5 MHz versions
- VERY HIGH SENSITIVITY (-109 dBm)
- VERY LOW CURRENT CONSUMPTION
- SINGLE 5V SUPPLY
- DIGITAL, AUDIO & RSSI OUTPUT

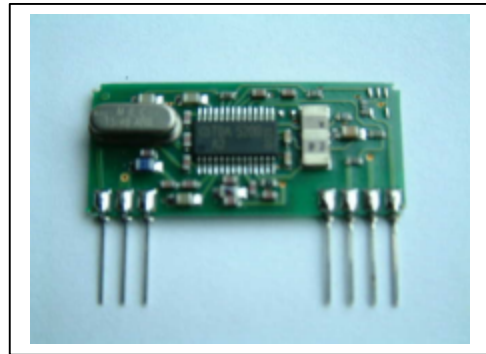

Applications

- VEHICLE ALARM SYSTEMS
- REMOTE GATE CONTROLS
- GARAGE DOOR OPENERS
- DOMESTIC AND COMMERCIAL SECURITY

Compatible Transmitter Modules

- RS-MKT1-XXX
- RS-MKT1HP

General Description

The RS-MKR2AM-XXX miniature receiver UHF radio module enables the implementation of a simple telemetry link at data rates of up to 10Kbit/s when used with one of the compatible RS-MK transmitter modules

Available for operation at 868/916 MHz, these modules are able to receive at distances of up to 100m.

The RS-MKR2AM-XXX module will suit one-to-one and multi-node wireless links in applications including building and car security, remote industrial process monitoring and computer networking. Because of its small size and low power requirements, the module is ideal for use in portable battery powered wireless applications.

Absolute Maximum Ratings: Receiver

Operating temperature:

-10°C to +55°C

Storage temperature:

-40°C to +100°C

Supply Voltage (pin 1)

5V

RF input (pin 3)

± 50V @ < 10 MHz, +20 dBm @ > 10 MHz

Electrical Characteristics: Receiver

	pin	min.	typ.	max.	units	notes
DC LEVELS						
Supply voltage		4,5	5	5,5	V	
Supply current			4,5		mA	
Supply ripple		-	-	10	mV _{p-p}	
Data output high			4,0		V	
Data output low			<=0,5		V	
RF						
RF sensitivity @ 433.92 MHz			-109		dBm	
RF sensitivity @ 868,35 MHz			-109		dBm	
RF sensitivity @ 916,5 MHz			-109		dBm	
IF Bandwidth			230		KHz	
Initial frequency accuracy			±30		KHz	
Max R.F. input			-5		dBm	
E.M.C.						
Spurious responses upto 1 GHz			<60		dB	
LO leakage, conducted			<60		dBm	
LO leakage, radiated			<60		dBm	
DYNAMIC TIMING						
Power up with signal present						
Power up to stable data			125		mS	1
Signal applied with supply on						
Signal to stable data			100		mS	
Minimum pulse width allowed		0.1			mS	
Maximum pulse width allowed				50	mS	
Bit rate		40		10000	bps	

1) A faster version is available providing stable data within 20mS of power up. Please enquire for further information.

Connection Details

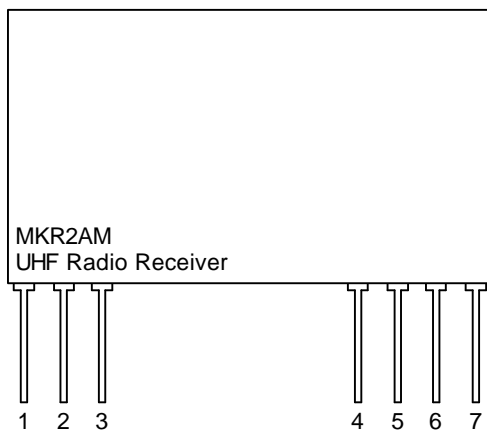

Figure 1: RS-MKR2AM Receiver

Pin Description

V_{CC} (pin 1)

+Ve supply pin. Operation from a 5V supply able to source 10mA at less than 10mV_{P,P} ripple.

GND (pin2)

Supply ground connection, preferably connected to a solid ground plane.

RF IN (pin 3)

50Ω RF input from antenna, connect using shortest possible route. Capacitively isolated from internal circuit.

UNCONNECTED (pins 4)

Extra SIL pin for additional mechanical retention.

AF (PIN 5)

Audio frequency output. Note source current is limited to 40uA. In most applications a buffer may be required to interface to this pin.

RSSI (pin 6)

This is a dc output voltage that is proportional to the RF signal strength applied to pin 3.

DATA OUT (pin 7)

CMOS compatible output. This may be used to drive external decoders.

General Information

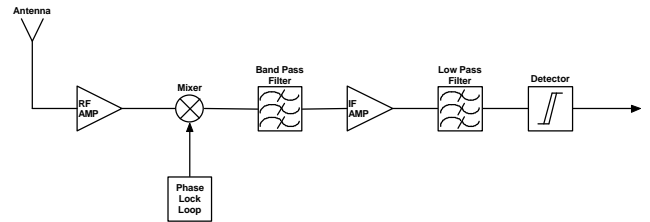

Figure 2:- RS-MKR2AM Receiver Block Diagram

The RS-MKR2AM receiver module is a FM single conversion superhet receiver capable of handling data rates of up to 10Kbits/s. With an on board data buffer, phase locked loop and a high quality front end RF stage a -109 dBm sensitivity is achieved.

Utilising the latest phase locked loop receiver technology with one of the compatible RS-MK transmitter modules will yield a highly efficient wireless link.

Application Information

Antenna Design

The design and positioning of the antenna is as crucial as the module performance itself in achieving a good wireless system range. The following will assist the designer in maximising system performance.

The antenna should be kept as far away from sources of electrical interference as physically possible. If necessary, additional power line decoupling capacitors should be placed close to the module.

The antenna ‘hot end’ should be kept clear of any objects, especially any metal as this can severely restrict the efficiency of the antenna to receive power. Any earth planes restricting the radiation path to the antenna will also have the same effect.

Best range is achieved with either a straight piece of wire, rod or PCB track @ ¼ wavelength (8cm @ 868.35MHz). Further range may be achieved if the ¼ wave antenna is placed perpendicular in the middle of a solid earth plane measuring at least 16cm radius. In this case, the antenna should be connected to the module via some 50 ohm characteristic impedance coax

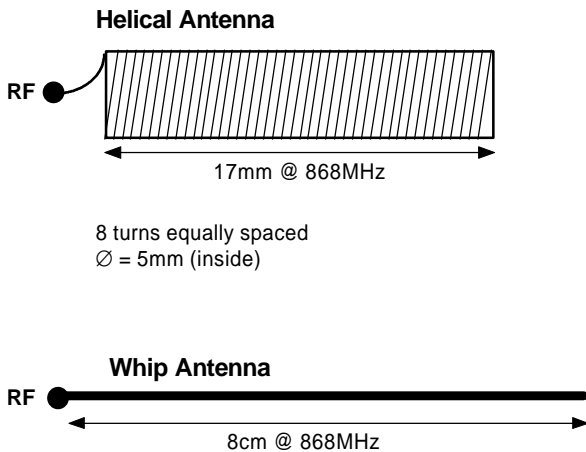

Figure 3: Antenna configurations to be used with the RS-MK modules

Application Circuit

The application circuit shows how the RS-MKR2AM receiver can easily be integrated into a system to form a wireless link.

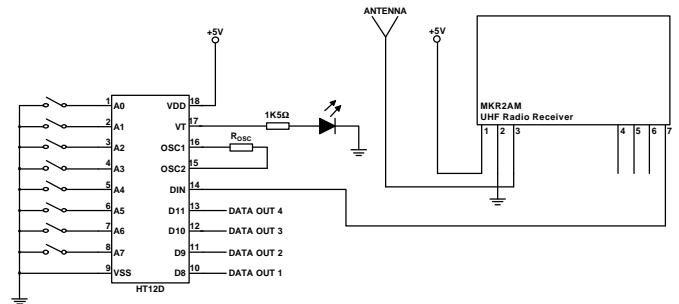

Figure 4: RS-MKR2AM Receiver Application Circuit

RSSI Values

RF Input (-dBm)	RSSI (V)
110	1.12
100	1.44
90	1.69
80	1.85
70	1.85
60	2.10
50	2.38
40	2.67
30	2.77

Mechanical Dimensions

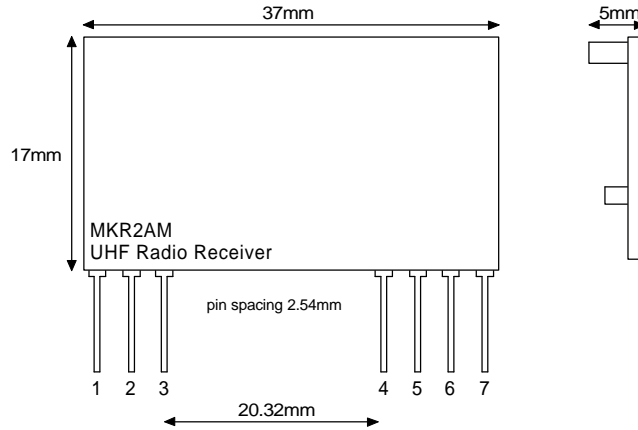

Figure 5: RS-MKR2AM Receiver

Ordering Information

Standard Product;

Part No	Description
RS-MKR2AM-434	AM SIL Receiver 433.92 MHz
RS-MKR2AM-868	AM SIL Receiver 868,35 MHz
RS-MKR2AM-916	AM SIL Receiver 916,5 MHz

Please consult our sales department for further information.

Round Solutions Ltd
 German Branch
 Zaunweg 4
 D-63303 Dreieich
 Germany

Tel: +49 (0) 6103 960510
 Fax: +49 (0) 6103 960509

Email: info@roundsolutions.com
 Web: www.roundsolutions.com