

## General Description

The Genesis RS-GT1 'wireless connector' transmitter module represents the culmination of a two year evolutionary radio design process whose aim was to provide wireless connectivity in the 434 MHz ISM band with a pair of modules that will provide seamless and reliable operation for the next decade. Utilising medium band RF technology, the Genesis FM transmitter is initially available on three separate channels within the same ISM band and having the capability to generate up to 25mW of RF power. Packaged in a miniature 32 x 10mm fully shielded enclosure and operating from 3v or 5v supplies, Genesis transmitters have retained the industry standard footprints.

This means that coupled with the corresponding receiver which has an intelligent data slicer, Genesis modules can certainly be incorporated into both new and existing designs.

### *'Wireless connector'*

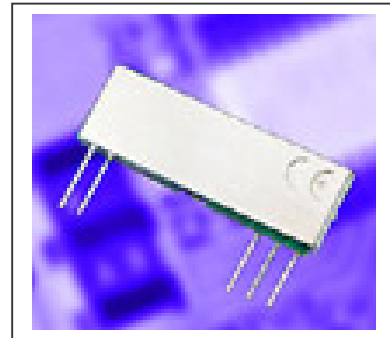

## Compatible Receiver Modules

- GENESIS R1 (RS-GR1)
- RS-R7

## Applications

- REMOTE CONTROL FOR CRANES ETC
- WIRELESS MONITORING
- DISPERSED ALARM APPLICATIONS
- DOMESTIC AND COMMERCIAL SECURITY WIRELESS TELEMETRY

## Features

- MINIATURE SIL PACKAGE
- UP TO 25mW RF OUTPUT POWER
- DATA RATES UP TO 15 KBITS/S
- MEDIUM BAND CRYSTAL TECHNOLOGY
- 1Km+ RANGE WITH GR1 RECEIVER
- COMMON GENESIS FOOTPRINT – CHOOSE BETWEEN 100 TO 1000 MHz OPERATION

- AVAILABLE ON 433.92, 434.225 & 434.525 MHz CHANNELS
- OTHER CHANNELS AVAILABLE ON REQUEST
- SINGLE 3 & 5 VOLT SUPPLY
- EN 300-220-1 compliant module

**Absolute Maximum Ratings: Transmitter**

Operating temperature:	-10°C to +55°C
Storage temperature:	-40°C to +100°C
Supply Voltage (pin 3)	5.5V
Data input (pin 5)	5.5V

**Electrical Characteristics: Transmitter 5v version**

	pin	min.	Typ.	max.	units	notes
<b>DC LEVELS</b>						
Supply voltage	3	4.5	5.0	5.5	Volts	
<b>Current &amp; RF POWER</b>						
434.225 MHz (Applies to all channels)						
Supply current @ $V_{CC} = 5V$	3		24		mA	1
RF power	2		25		mW	1
<b>RF &amp; Data</b>						
2 <sup>nd</sup> harmonic			-40		dBm	2
Harmonics @ > 1GHz			-50		dBm	2
Initial frequency accuracy			+/-25		Hz	
Frequency accuracy over full temp range				±27	KHz	
FM deviation of RF carrier			30		KHz	
Power up time to full RF			5		ms	
Data rate				15	kbits/s	
Data pulse width		66.6			µs	

- Note 1:** measured into a 50Ω impedance  
**Note 2:** the limit for the European spec EN 300 220 is -36dBm

## Connection Details

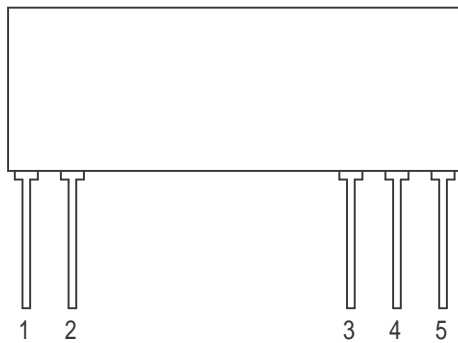

Figure 1: Genesis Transmitter

## Pin Description:

### RF GND (pin 1)

RF ground pin, internally connected to pin 4 (0V). This pin should ideally be connected to the nearest ground plane (e.g. coax braid, main PCB ground plane etc.)

### RF OUT (pin 2)

50Ω RF antenna output. To achieve best results the antenna impedance must match that of the module.

### V<sub>CC</sub> (pin 3)

+Ve supply pin. The module will generate RF when V<sub>CC</sub> is present.

### GND (pin 4)

Supply and data ground connection, connected to pin 1.

### Data IN (pin 5)

This input has an impedance of 47KΩ and should ideally be driven by a CMOS logic drive or compatible.

## Reducing Power to 10mW

If the transmitter will be used with an efficient antenna in countries where only 10mW radiated power is allowed, then a simple resistive network on the output of the module will attenuate the power down to this level.

### Circuit Diagram

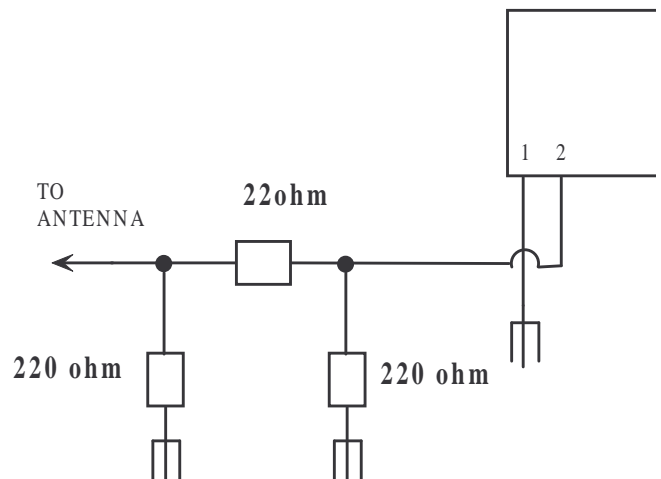

When laying out this network, keep all tracks as short as possible, especially ground paths and use 50 ohm track impedances when connecting to and from this network. This impedance can be realised on 1.6mm FR4 pcb by using a track width of 2.5mm.

### Application Information

#### Antenna Design

The design and positioning of the antenna is as crucial as the module performance itself in achieving a good wireless system range. The following will assist the designer in maximising system performance.

The antenna should be kept as far away from sources of electrical interference as physically possible. If necessary, additional power line decoupling capacitors should be placed close to the module.

The antenna ‘hot end’ should be kept clear of any objects, especially any metal as this can severely restrict the efficiency of the antenna to receive power. Any earth planes restricting the radiation path to the antenna will also have the same effect.

Best range is achieved with either a straight piece of wire, rod or PCB track @ ¼ wavelength (15.5cm @ 434 MHz). Further range may be achieved if the ¼ wave antenna is placed perpendicular in the middle of a solid earth plane measuring at least 30cm radius. In this case, the antenna should be connected to the module via some 50 ohm characteristic impedance coax

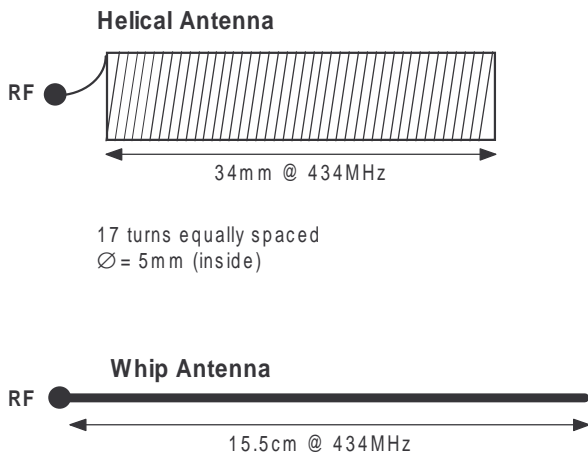

Figure 2: Antenna Configurations To Be Used With The Genesis Transmitter Modules

### Application Circuit

The application circuit shows how the Genesis transmitter can easily be integrated into a system to form a wireless link

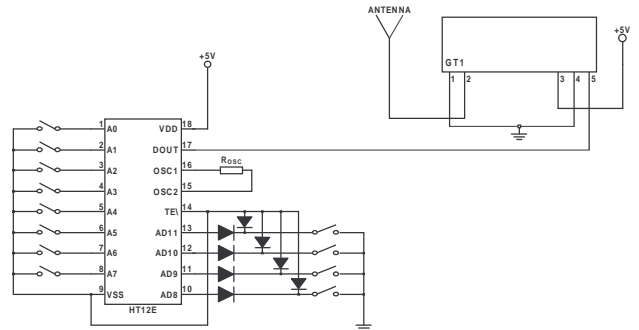

Figure 3: MK Transmitter Application Circuit

## Mechanical Dimensions

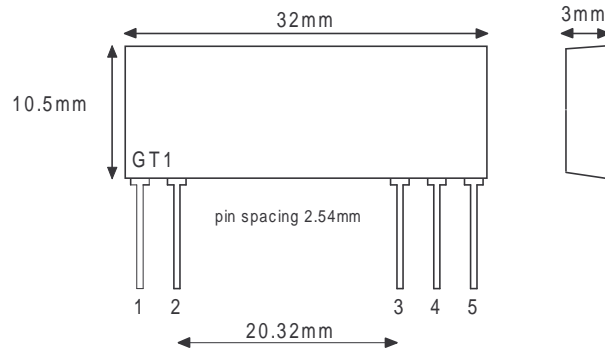

Figure 4: Genesis Transmitter

## Ordering Information

### Standard Product;

Part No	Description
RS-GT1-433.92	Genesis Transmitter 433.92 MHz
RS-GT1-434.225	Genesis Transmitter 434.225 MHz
RS-GT1-434.525	Genesis Transmitter 434.525 MHz

Please consult our sales department for further information.

### Round Solutions GmbH & Co KG

Zaunweg 4  
63303 Dreieich  
Germany

Tel +49 (0) 6103 960510

Fax +49 (0) 6103 960509

Email: [info@roundsolutions.com](mailto:info@roundsolutions.com)

Web: [www.roundsolutions.com](http://www.roundsolutions.com)

### Disclaimer

Round Solutions have a policy to continually improve the reliability and performance of their products. We therefore reserve the right to upgrade our products performance without notice.

Although the data contained herewith is believed to be accurate, however we do not assume any responsibility whatsoever for errors or omissions this document may contain.

In addition, we do not imply warranty or fitness for any particular application especially life support applications.