

General Description

The Genesis 'wireless connector' receiver module that complements the GT1 transmitter is again a remarkable product that has evolved over the past couple of years into a industry standard form factor but with exceptional performance compared to the price of the module.

The receiver sensitivity alone at -117dBm is comparable to most narrow band receivers however and surprisingly the RS-GR1 is very favourable in price.

Fully shielded and measuring just 17 x 48mm, Genesis provides a superior route to enhancing the performance of current and future wireless enabled devices.

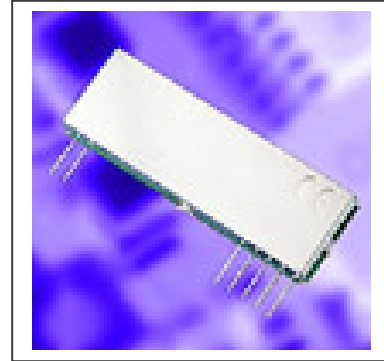

Applications

- Telemetry systems
- Remote switching applications
- Paging systems
- Domestic and commercial security

Features

- Miniature SIL package
- Single conversion FM Super-het using RF SAW and ceramic IF filtering
- Provides over 1Km range especially when used with the GT1 transmitter module
- Fully shielded

Compatible Transmitter Modules

- RS-T7 (5mW transmitter module)
- RS-GT1 (25mW transmitter module)

- Analogue, Digital and true RSSI outputs
- DATA RATES UP TO 15KBITS/S
- Operation on 433.92, 434.225 & 434.525 MHz
- HIGH SENSITIVITY (-117 dBm)
- Low current consumption (11mA)
- SINGLE 5V SUPPLY

Absolute Maximum Ratings: Receiver

Operating temperature:	-10°C to +55°C -40 to +80 deg C option available
Storage temperature:	-40°C to +100°C
Supply Voltage (pin 5)	5.5V
RF Input (pin 1)	10mW

Electrical Characteristics: Receiver (All frequency versions at 25degC)

	pin	min.	typ.	max.	units	notes
DC LEVELS						
Supply voltage		4.5	5	5.5	V	
Supply current			11		mA	
Supply ripple		-	-	10	mV _{P-P}	
Data output high			=>4.0		V	
Data output low			<= 0.5		V	
RF						
RF sensitivity			-117		dBm	1
IF Bandwidth			+/-27		KHz	
Initial frequency accuracy			±25		Hz	
Max R.F. input			10		dBm	
E.M.C.						
Spurious responses upto 1GHz			<60		dB	
LO leakage, conducted			<60		dBm	
LO leakage, radiated			<60		dBm	
Image rejection			35		dB	
DYNAMIC TIMING						
Power up to stable data (With RF signal present)			110		mS	
Signal to stable data (With power supply already on)			1		mS	
Power up to valid RSSI (with RF signal present)			2.5	3.5	mS	
Mark:space ratio			50		%	
Bit rate		100		15000	bps	2

Notes

- 1) For 12 dB SINAD from the AF output
- 2) Note 1Hz = 2 bps

Connection Details

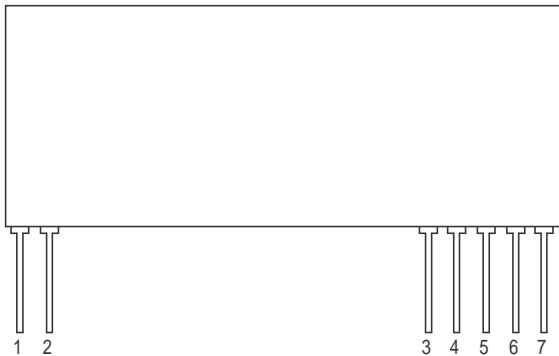

Figure 1: RS-GR1 Receiver

Pin Description

RF IN (*pin 1*)

50 Ω RF input from antenna, connect using shortest possible route. This input is isolated from the internal circuit using the air gap of the front end SAW RF filter.

RF GND (*pin 2*)

RF ground connection, preferably connected to a solid ground plane.

RSSI / Carrier Detect (*pin 3*)

The Received Signal Strength Indicator provides a DC output voltage proportional to the RF input signal. The amplitude of the RSSI voltage increases with increasing RF signal strength. A simple transistor interface can yield a carrier detect logic output.

Gnd (*pin 4*)

Connect to power supply ground

V_{CC} (*pin 5*)

+Ve supply pin. Operation from a 5V supply able to source 10mA at less than 10mV_{P-P} ripple.

AF (*pin 6*)

Audio frequency output 100mV p-p.(max 40uA source)

DATA OUT (*pin 7*)

CMOS compatible output. This may be used to drive external decoders.

Application Information

Antenna Design

The design and positioning of the antenna is as crucial as the module performance itself in achieving a good wireless system range. The following will assist the designer in maximising system performance.

The antenna should be kept as far away from sources of electrical interference as physically possible. If necessary, additional power line decoupling capacitors should be placed close to the module.

The antenna ‘hot end’ should be kept clear of any objects, especially any metal as this can severely restrict the efficiency of the antenna to receive power. Any earth planes restricting the radiation path to the antenna will also have the same effect.

Best range is achieved with either a straight piece of wire, rod or PCB track @ ¼ wavelength (15.5cm @ 433.92MHz). Further range may be achieved if the ¼ wave antenna is placed perpendicular in the middle of a solid earth plane measuring at least 10cm radius. In this case, the antenna should be connected to the module via some 50 ohm characteristic impedance coax.

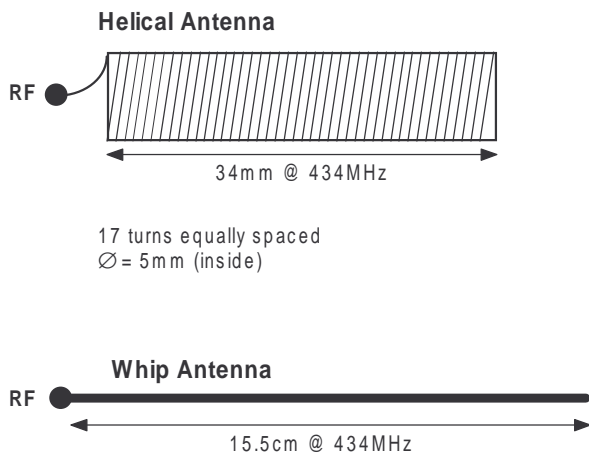

Figure 2: Antenna Configurations To Be Used With The Genesis receiver Module

Application Circuit

The application circuit shows how the RS-GR1 Receiver can easily be integrated into a system to form a wireless link.

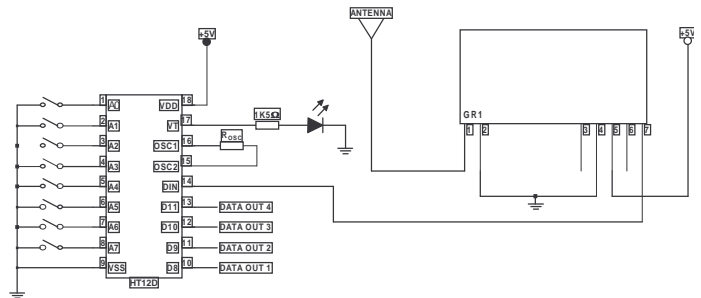

Figure 3: Genesis Receiver Application Circuit

RSSI Values

The RS-GR1 RSSI output provides a DC output proportional to the RF input signal. The table below shows the typical RSSI value depending on the RF signal strength.

RF Signal Strength / dBm	RSSI / V
-130	1.25
-120	1.32
-110	1.46
-100	1.69
-90	1.96
-80	2.2
-70	2.47
-60	2.5
-50	2.5

Please note that in your application the above values could be offset however the general curve will remain similar.

Mechanical Dimensions

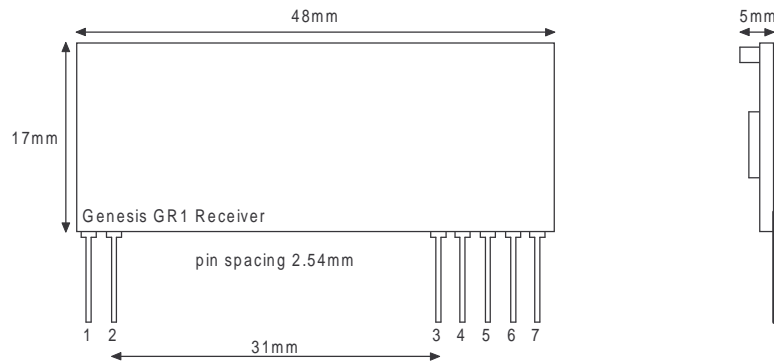

Figure 4: Genesis Receiver

Ordering Information

Standard Product;

Part No	Description
RS-GR1-433.92	433.92 MHz receiver module
RS-GR1-434.225	434.225 MHz receiver module
RS-GR1-434.525	434.525 MHz receiver module

Please consult our sales department for further information.

Round Solutions GmbH & Co KG

Zaunweg 4
63303 Dreieich
Germany

Tel +49 (0) 6103 960510
Fax +49 (0) 6103 960509

Email: info@roundsolutions.com
Web: www.roundsolutions.com

Disclaimer

Round Solutions have a policy to continually improve the reliability and performance of their products. We therefore reserve the right to upgrade our products performance without notice.

Although the data contained herewith is believed to be accurate, however we do not assume any responsibility whatsoever for errors or omissions this document may contain.

In addition, we do not imply warranty or fitness for any particular application especially life support applications.